

EMAIL SUBMITTALS TO:
sendbid@cityoftacoma.org

**CITY OF TACOMA
 REQUEST FOR BID**

BID NO.: PT25-0072N
 BUYER: Aaron Bratton
 PHONE: 253-502-8139
 FAX: 253-502-8372
 DATE: 03/10/2025

SURPLUS PROPERTY SALE

BIDS will be received until **11:00 a.m., Monday, March 24, 2025,**

FOR: Purchase of items listed below. Weights and quantities are estimated. Items will be sold as-is and where-is, and in accordance with instructions attached hereto. Freight costs and arrangements are the responsibility of the bidder. Bids must be submitted on this form.

LOCATION OF SURPLUS PROPERTY: see below

VIEWING CONTACT: Sean Veley 253-502-8713

_____, the undersigned hereby agrees to purchase items as indicated below, at prices shown for each:

QUANTITY	DESCRIPTION	UNIT PRICE		TOTAL	
	ALL PRICES QUOTED SHALL BE F.O.B. ORIGIN				
1	25 MVA Distribution Transformer	\$	Ea	\$ _____	_____
	Vendor confirms that all transformers will be removed within 60 days of notice that all documentation is complete and equipment is available for pick-up:				
	<input type="checkbox"/> Yes <input type="checkbox"/> No				
			Sub-Total:	\$ _____	_____
			Sales Tax:	\$ _____	_____
			Grand Total:	\$ _____	_____
	* SOLD AS IS - WHERE IS *				
	This Sale May be Subject to Council or Utility Board Approval				

Bidder certifies that this purchase is for resale in the regular course of business, or is to be used as an ingredient or component part of a new article of tangible personal property to be produced for sale, or is a chemical to be used in processing an article to be produced for sale.

Resale No.: _____

Signed: _____

If not applicable, Washington State sales tax will apply and will be added to the bid amount.

The Undersigned hereby agrees to purchase any or all items described above in accordance with conditions and instructions contained in this bid call:

Bidder: _____ Phone: _____

Address: _____ City/State/Zip: _____

Printed Name/Title _____ Fax: _____

Signed: _____ Date: _____

CITY OF TACOMA

GENERAL INSTRUCTIONS FOR BIDDING ON SURPLUS PROPERTY

Submittal Information

Sealed bids must be delivered to the office designated on the attached form, on or before the time mentioned thereon. Any bid received after the established opening time will not be considered, and will be returned to the bidder unopened.

When specified by the City, bids must be accompanied by a Certified or Cashier's check as a bid and performance guarantee (good faith deposit) in an amount not less than five percent (5%) of the amount of the bid, made payable to "Treasurer, City of Tacoma." Cash will not be accepted. Deposit checks will be returned to unsuccessful bidders after award of the bid to the successful bidder. The deposit of successful bidder shall be applied to the purchase price. If the successful bidder fails to consummate the purchase, such deposit shall be forfeited as liquidated damages to the City of Tacoma.

Bids must be valid for a minimum of 30 days after the opening date.

Bidders may inspect the items offered for sale at the location indicated on the attached form.

The City reserves the right to reject any or all bids received, to award any or all of the various items to separate bidders, to waive any informalities in the bids, and to award as best serves the interest of the City.

Disclaimer of Warranty

All items are sold AS-IS and WHERE-IS, with all faults. The Seller makes no warranty, express or implied with respect to the condition of the goods. SELLER SPECIFICALLY DISCLAIMS ANY AND ALL UCC WARRANTIES OF MERCHANTABILITY AND FITNESS FOR A PARTICULAR PURPOSE.

Quantities/Payment

Unless otherwise indicated, quantities and/or weights are estimates only. Buyer shall not be entitled to any price adjustment in the event of variance in the estimated quantity. The total sale amount will be based on the unit prices quoted and the total quantity or weight as determined by scale weight at the time material is picked up.

Within one week from date of notification of award, the successful bidder must make payment in full for all items awarded. Payment for metals or other items that must be weighed shall be based on the estimated quantities as shown in the bid call, with final payment adjustment to be made based on actual weights picked up as ascertained by the scale tickets. All payments are to be by Certified or Cashier's check, made payable to "**Treasurer, City of Tacoma.**"

Any material, equipment or other items bid upon must be removed by the successful bidder within one week from date of notification of award, unless stated otherwise under special instructions. Material bid on may be added to by like material through normal course of operation of the City of Tacoma between the time of the bid opening and the time the salvage is picked up. However, all material in any designated bin or location must be removed during the normal course of pick-up by the successful bidder.

The successful bidder will be required to pay Washington State sales tax, unless he/she is a qualified dealer, in which case he/she must furnish his/her resale number, as indicated on the bid form.

Hazardous/Toxic Substances

The Buyer shall abide by all local, state and federal laws and regulations pertaining to the use, transport, handling, reclamation, and disposal of hazardous or toxic substances, including but not limited to the following: The Toxic Substance Control Act; the Resource Conservation and Recovery Act; the Comprehensive Environmental Response, Compensation and Liability Act; the Hazardous Materials Transportation Act; the Hazardous Waste Management Act; the Occupational Safety and Health Act; and the Washington Industrial Safety and Health Act.

Indemnification - Hold Harmless

Purchaser acknowledges that pursuant to the terms of this agreement, Purchaser is totally responsible for the safety of all persons and property in the performance of this contract. Purchaser assumes the risk of all damages, loss, cost, penalties and expense and agrees to indemnify, defend and hold harmless the City of Tacoma, from and against any and all liability which may accrue to or be sustained by the City of Tacoma on account of any claim, suit or legal action made or brought against the City of Tacoma for the death of or injury to persons (including Purchaser's or subcontractor's employees) or damage to property involving Purchaser, or subcontractor(s) and their employees or agents, or for any other cause arising out of and in connection with or incident to the performance of the contract except for injuries or damages caused by the sole negligence of the City. In this regard, Purchaser recognizes that Purchaser is waiving immunity under Industrial Insurance Law, Title 51 RCW. This indemnification extends to the officials, officers and employees of the City and also includes attorney's fees and the cost of establishing the right to indemnification hereunder in favor of the City of Tacoma.

Supplier Verification

To be considered, all bidders must provide the information in full below.

1. History
 - a. Provide a short history and description of your firm including name, address, number of employees and organizational structure.
2. Examples of Projects
 - a. Describe three projects your firm has undertaken in the last five years that are similar in scope and complexity to this project's scope of work.
3. Client References
 - a. Provide three client references able to verify the firm's overall expertise for this type of work. The references must have worked with the firm within the last five years.
 - b. Provide complete information such as name of company, contact person, address, phone number, and email address.
4. Qualifications / Experience of Key Personnel
 - a. List key personnel that will handle the project. The personnel listed must be committed to this project for the expected term of the agreement. Include a brief bio or resume outlining the experience of the key personnel that will be involved.
 - b. Has your business been in business for at least 5 years.
5. Sustainability
 - a. Provide information on your company's commitment to the environment. Include your sustainability statement and current practices.
6. Insurance
 - a. Provide proof of \$1 million dollars in pollution liability insurance.
 - b. Provide a copy of their Experience Modification Rating (EMR) from their insurer.
7. Dismantling
 - a. Provide an EPA identification number and address of the facility that the equipment will be taken to for decommissioning/dismantling.
 - b. Provide the location where the equipment decommissioning/dismantling will take place = Provide a summary of permit violations, fines, and non-compliance for the past 5 years.
 - c. Provide the US DOT Number of the transporter that will be used.



CITY OF TACOMA

SURPLUS PROPERTY DISPOSAL/SPECIFICATION NO.
FROM (Dept):
TO (Purchaser/Recipient):

Indemnification--Hold Harmless

Purchaser/Recipient acknowledges that pursuant to the terms of this agreement, Purchaser/Recipient is totally responsible for the safety of all persons and property in the performance of this contract. Purchaser/Recipient assumes the risk of all damages, loss, cost, penalties and expense and agrees to indemnify, defend and hold harmless the City of Tacoma, from and against any and all liability which may accrue to or be sustained by the City of Tacoma on account of any claim, suit or legal action made or brought against the City of Tacoma for the death of or injury to persons (including Purchaser/Recipient's or subcontractor's employees) or damage to property involving Purchaser/Recipient, or subcontractor(s) and their employees or agents, or for any other cause arising out of and in connection with or incident to the performance of the contract except for injuries or damages caused by the sole negligence of the City. In this regard, Purchaser/Recipient recognizes that Purchaser/Recipient is waiving immunity under Industrial Insurance Law, Title 51 RCW. This indemnification extends to the officials, officers and employees of the City and also includes attorney's fees and the cost of establishing the right to indemnification thereunder in favor of the City of Tacoma.

ITEM: _____ **\$** _____

PURCHASER/RECIPIENT: _____

ADDRESS: _____

CITY & STATE: _____ **ZIP CODE** _____

PHONE: _____

NAME: _____ **DATE:** _____

SIGNATURE: _____

All items are sold/donated/salvaged AS-IS and WHERE-IS, with all faults. Freight costs and arrangements are the responsibility of the bidder. The City of Tacoma makes no warranty, express or implied, with respect to the condition of the goods. The City of Tacoma specifically **DISCLAIMS ANY AND ALL UCC WARRANTIES OF MERCHANTABILITY AND FITNESS FOR A PARTICULAR PURPOSE.**

TACOMA POWER

SUBSTATION SURPLUS EQUIPMENT

Elk Plain Substation Transformer

The transformer is available as is, where is. All equipment has been drained of insulating oil by Tacoma Power; however, residual oil will be present and should be anticipated by the bidder. The currently available equipment, all of which are located at Tacoma Power's Elk Plain Substation, are summarized below.

Item 1: 1974 25 MVA, 115KV to 13.09KV step down Westinghouse power transformer weighing approximately 71,000 LBS.

The below contains photos and descriptions of equipment. All equipment may be examined prior to the bid deadline on a limited, escorted basis. Contact Sean Veley at (253) 502-8713 or Sean Forslund at (253) 502-8235 to arrange a visit or for any other questions regarding this offering.

On-site demolition will not be allowed, but it is anticipated that the equipment will need to be partially dismantled to allow for safe shipment, such as, but not limited to, the removal of High Voltage Bushings. Dismantling should only consist of that which is necessary to safely transport the equipment. Any further disassembly and demolition, such as for salvage/recycling separation, will take place off-site at bidder's location. Bidder is to provide and assume responsibilities and costs for ALL dismantling, demolition, and transportation requirements, such as, but not limited to tools, equipment, supplies, vehicles, permits and/or fees.

All work must be completed within the allowed time frames. The bidder shall indicate in their bid, their intent and method of equipment dismantle. Bidder must clearly identify the type of work to be performed and include plans and safety measures to perform the work and prevent any loss of oil or other contaminants to the substation soils. Any failure to supply the requested information may result in bid disqualification.

The successful bidder shall abide by all local, state, and federal laws and regulations pertaining to the use, transport, handling, reclamation, and disposal of hazardous or toxic substances.

The surplus equipment is located at the following location:

Elk Plain Substation
22312 46TH AV E
Spanaway, WA 98387

All equipment must be removed from the substation according to the schedule described below.

Schedule:

The contractor will be allowed no more than **2 working days** to remove all listed equipment from the substation. If the availability of the substation is delayed, 2 full days will still be available for removal.

The successful bidder must ensure they can complete the transformer removal by June 1, 2025; however, this may have to be adjusted due outage availability. A specific outage date can be negotiated with the awarded bidder. All work in the substations or on Tacoma Power property will be attended by a qualified Tacoma Power electrician as required by state electrical safety regulations. Tacoma Power will supply a qualified electrician between the hours of 8 am to 12 pm and 12:30 pm to 4:30 pm for the duration of the 5-day period, at no charge to the contractor. The contractor may arrange for additional hours at their own expense. The contractor must provide at least 24-hour's notice of any schedule extension beyond the times listed above.

If the contractor fails to complete equipment removal from the station by the end of the allowed time, they will not be allowed into the substation and all remaining electrical equipment will be forfeited in the interest of preparing the site for necessary construction. There will be no refunds for failure to meet this schedule.

Training:

Prior to entering the substations, all workers are required to receive mandatory substation safety training provided by Tacoma Power. This includes transient workers such as truck drivers. The training is provided at no cost during regular work hours and takes 1 hour.

Oil Spill Prevention:

Washington state environmental regulations require the reporting and cleanup of all oil spills, even very small spills. The contractor will not be allowed to spill any oil during removal of the transformer. This includes oil from the transformer and equipment used during the removal process, including hydraulic systems. Oil contaminated materials will not be allowed to be placed on unprotected soils and the contractor must be prepared for all weather conditions. Work practices that are considered unsafe or likely to result in oil contamination will be stopped by the Tacoma Power supervisor until deficiencies are corrected. No additional removal time will be allowed for work stopped due to improper practices. All oil spilled will be remediated to state and Tacoma Power standards at the contractor's cost.

Work Plan:

The contractor must supply a brief work plan with their bid that includes general information about their process for removing the equipment including bushing removal/delivery to the transformer shop, general process for dismantling the equipment, expected schedule (including weekend and overtime work) for Tacoma Power planning needs, and the general process for preventing oil spills.

The bidder with the highest acceptable bid will be notified and must supply a detailed work plan within 10 days. The specific requirements for the work plan will be detailed by Tacoma Power when the

notification is made. A detailed work plan may not be necessary depending on the plan submitted with the bid. Failure to supply an acceptable work plan within 10 days may be grounds to reject the bid.

Safety:

The contractor must abide by all safety regulations while working on Tacoma Power property. Special attention includes, but is not limited to, fall protection, confined space entry, and lead exposure for work on the equipment. All high voltage power lines located near the equipment will be de-energized and there should be enough clearance to place a crane to lift the equipment for loading/size reduction purposes. The contractor must maintain proper clearance, as directed by the on-site safety watch, from all energized lines.

Every Tacoma Power employee is acutely aware of safe operating practices and is authorized to stop any work they consider to be unsafe. The contractor will abide by any direction to stop work for safety reasons upon notice by any Tacoma Power employee. The contractor will immediately correct any condition or practice determined to be unsafe. No time extension will be allowed for work stoppage due to unsafe work practices.

Westinghouse



THREE PHASE
60 HERTZ
TYPE SL
LOAD TAP CHANGING
TRANSFORMER
CLASS OA/FA/FA
INSULDUR INSULATION

WINDING 65°C. AVG. RISE
H.V. 115,000 VOLTS 15,000/20,000/25,000 KVA
L.V. 13090Y/7560 VOLTS 15,000/20,000/25,000 KVA
L. SPEC. 934781

INSTRUCTION BOOK RDP-1466

SERIAL No. RDP-14662

GALLONS OIL: TRANS. TANK 5910 TAP CHANGER COMPARTMENT 360
BIL: H.V. WDG. 450KV., H.V. BUSH. 550KV., L.V. WDG. 110KV.,
L.V. WDG. NEUT. 110KV., L.V. NEUT. BUSH. 110KV.
IMPEDANCE 8.2 % AT 15,000kVA 115,000 TO 13090 VOLTS

1975
MADE IN U.S.A.

APPROX. WEIGHT IN LBS. CORE AND COILS 40,400 CASE 30,700 OIL 47,000 TOTAL 118,100
WESTINGHOUSE ELECTRIC CORPORATION

21BP353H01B

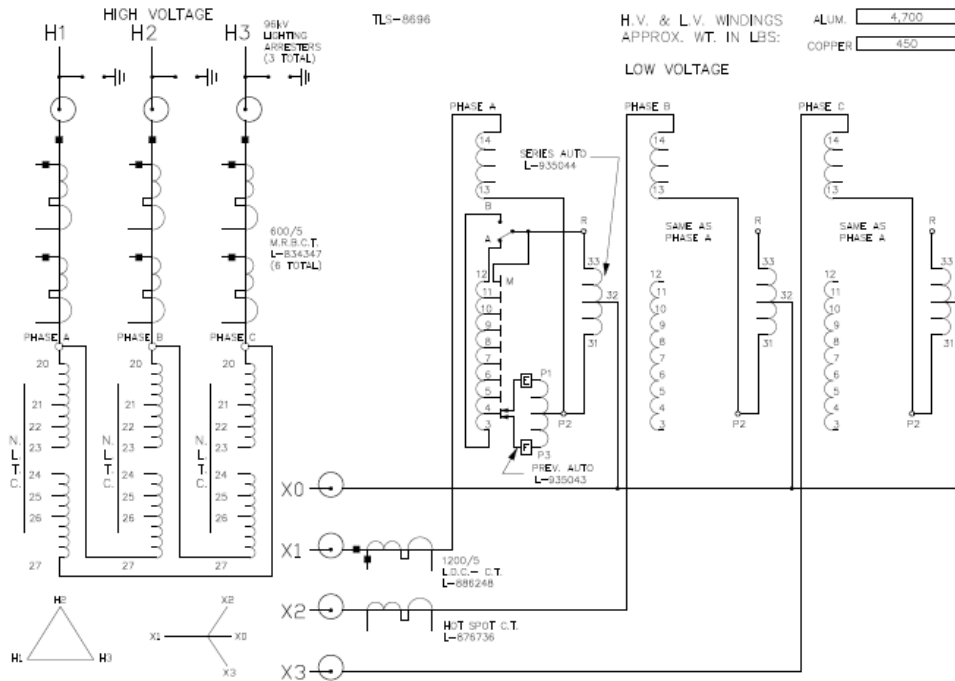

CONNECTIONS

WINDING	VOLTS	25000KVA AMPERES	NO LOAD TAP CHANGER		LOAD TAP CHANGER				
			POS.	CONNECTS	POS.	CONNECTS			
						PT ON	P3 ON	R ON	
HIGH VOLTAGE DELTA	115,000	125.5	1	23-24					
	112,125	126.7	2	22-24					
	109,250	132.1	3	22-25					
	106,375	135.7	4	21-25					
	103,500	139.5	5	21-26					
LOW VOLTAGE WYE	11,760	1102.6			L O W V O L T A G E	16	4	4	A
	11,945			14		5	5	A	
	12,100			12		6	6	A	
	12,270			10		7	7	A	
	12,435			8		8	8	A	
	12,600			6		9	9	A	
	12,765			4		10	10	A	
	12,925			2		11	11	A	
	13,080			N		M	M	A	
	13,225		1088.9	2		4	4	B	
	13,415		1075.9	4		5	5	B	
	13,580		1062.8	6		6	6	B	
	13,745		1050.0	8		7	7	B	
	13,910		1037.6	10		8	8	B	
	14,070		1025.8	12		9	9	B	
14,235	1013.9	14	10	10	B				
14,400	1002.3	16	11	11	B				

VOLTAGE AND CURRENT RATINGS FOR ODD NUMBERED POSITIONS OF LOAD TAP CHANGER ARE MIDWAY BETWEEN THOSE LISTED ABOVE. THE 25°C LIQUID LEVEL IS 4.38 INCHES BELOW TOP OF HIGHEST MANHOLE FLANGE. LIQUID LEVEL CHANGES .119 INCHES FOR EACH 10°C CHANGE IN AVERAGE LIQUID TEMPERATURE. THE TRANSFORMER MUST NOT BE ENERGIZED FROM ANY VOLTAGE SOURCE WHEN NO LOAD TAP CHANGERS ARE OPERATED. THE TRANSFORMER IS DESIGNED FOR OPERATION BETWEEN PRESSURE LIMITS OF 6.5 LBS. PER SQUARE INCH POSITIVE AND 6.5 LBS. PER SQUARE INCH NEGATIVE. THE TRANSFORMER TANK AND THE LOAD TAP CHANGER TANK ARE DESIGNED TO WITHSTAND COMPLETE VACUUM EITHER INDIVIDUALLY OR TOGETHER. WHILE VACUUM IS APPLIED TO EITHER ONE ALONE, THE PRESSURE IN THE OTHER MUST NOT BE GREATER THAN ATMOSPHERIC PRESSURE. UNTANKING WEIGHT (HEAVIEST PIECE) 35800 LBS. CONDUCTOR MATERIALS: H.V. AL., L.V. AL., R.V. CU., SERIES AUTO AL., PREV. AUTO AL.



