

**From:** twm1301@aol.com  
**Sent:** Saturday, September 14, 2024 12:29 PM  
**To:** City Clerk's Office; Woodards, Victoria; Hines, John; Bushnell, Joe; Walker, Kristina; Daniels, Kiara; Diaz, Olgy; Sadalge, Sandesh; Scott, Jamika; Rumbaugh, Sarah; Bacha, Chris (Legal); secretaryofstate@sos.wa.gov  
**Subject:** I-2117 Tacoma City Council Consideration Request for Resolution  
**Attachments:** CCR ref. I-2117 24 SEP Study Session.pdf

Greetings:

Finding this issue concerning, I would appreciate if you take the time to read the attached letter & the corresponding CCR and make your comments. I did attach the actual CCR to make it easier for you to locate for detailed reference.

I appreciate hearing from you. Thank you.

Monika May  
Resident South Tacoma

Re: Council Consideration Request (CCR) dated 9/11/24  
Item # 24-0990 on the Study Session Agenda 9/17/24  
Expressing opposition to Initiative 2117

Greetings,

After browsing the Agenda items for the above mentioned Study session and reading the CCR, I can not help but wonder why this specific item found it's place on the Agenda in the first place.

First I sought to find the definition of what a Resolution actually is. The two I found were:

- 1) A resolution is a non binding statement made by the Council. Formal expression of a particular position that are endorsed and signed by the Mayor.
- 2) An official statement or decision made by City Council to express its position, establish a policy to address a specific issue within the jurisdiction of the City.

My question would be why Madam Mayor Woodards, Deputy Mayor Hines, CM Walker and CM Diaz bring this to the table? On the actual ballot there are always statements as to "pro" or "con", but those statements are made by citizens and not elected officials.

Of course, each of the individuals mentioned are certainly free to vote their conscience as well as I am, but they should not try to influence anyone's decision by issuing such a Resolution in City Government as a whole. Would City Personnel feel compelled to agree with the Mayor and Councils stance?

Through the Ballot Initiative process I-2117 was approved by the people to be on our November ballot and nobody, in any capacity, should tell anyone how to vote and/or make official statements as this.

If, for any reason, I am to be corrected in my interpretation, please feel free to do so. I am always open to listen and discuss. I am looking forward to any and all responses. Thank you.

Respectfully,

Monika May  
South Tacoma



**CITY OF TACOMA, WASHINGTON  
OFFICE OF THE CITY COUNCIL  
COUNCIL CONSIDERATION REQUEST**

**TO:** Mayor and City Council  
**FROM:** Council Member Kristina Walker and Policy Analyst Christina Caan  
**COPIES TO:** Elizabeth Pauli, City Manager; Chris Bacha, City Attorney  
**SUBJECT:** **Resolution expressing opposition to Initiative 2117.**  
**DATE:** September 11, 2024

---

**I ask for a resolution expressing opposition to Initiative 2117.**

**BACKGROUND**

I ask for a resolution expressing opposition to Initiative 2117, which will appear on the November 5 General Election ballot in Washington.<sup>1</sup> The ballot measure proposes a prohibition on State agencies from imposing any type of carbon tax credit trading, including “cap and trade” or “cap and tax” programs.<sup>2</sup> It also proposes a repeal of sections of the 2021 Washington Climate Commitment Act (CCA) as amended, including repealing the creation and modification of a “cap and invest” program to reduce greenhouse gas emissions by specific entities.

As currently in place, the CCA sets a cap for carbon emissions that decreases over time and requires companies to either reduce their emissions or purchase allowances based on their emissions amount. Businesses that reduce emissions are allowed to sell their remaining emission allowance permits to other companies. All funds raised through the CCA can be allocated by the State Legislature to communities statewide for climate projects focused on improving clean transportation options, increasing climate resilience, and addressing issues of environmental justice and health inequity.<sup>3</sup>

In 2023, the first CCA auction enabled the State Legislature to appropriate \$2.1 billion for climate projects in the 2023-2025 biennium budget, including support for a variety of programs in Tacoma. The allocations benefiting Tacoma included projects such as:

- The Home Electrification Appliance Rebates Grant Program, which provided \$1.94 million to help income-constrained residents in Tacoma transition from using natural gas or oil-powered appliances to energy-efficient electric space and water heating appliances;<sup>4</sup> and
- The Washington Families Clean Energy Grant Program, which enabled Tacoma Power customers whose annual income does not exceed 150 percent of the area median income to receive a \$200 credit.<sup>5</sup> This program had a total funding of \$150 million statewide.

---

<sup>1</sup> [Washington Initiative 2117, Prohibit Carbon Tax Credit Trading and Repeal Carbon Cap-and-Invest Program Measure \(2024\) - Ballotpedia](#)

<sup>2</sup> [Initiative Measure No. 2117 \(wa.gov\)](#)

<sup>3</sup> [Climate Commitment Act - Washington State Department of Ecology](#)

<sup>4</sup> [City of Tacoma Receives \\$1.94M to Support Residential Transition from Fossil Fuels to Clean, Energy-Efficient Appliances - City of Tacoma](#)

<sup>5</sup> [You may qualify for a \\$200 credit on your power bill - Tacoma Public Utilities \(mytpu.org\)](#)

Passage of Initiative 2117 would eliminate the opportunity for similar awards to the City of Tacoma, as well as to other agencies and governments providing services to the Tacoma community, going forward.

DESIRED RESOLUTION DATE: September 24, 2024

**ALTERNATIVES**

The City Council could choose not to adopt the proposed resolution expressing opposition to the initiative.

**SPONSOR RECOMMENDATION**

Sponsors recommend the City Council consider the resolution on September 24, 2024.

**FISCAL IMPACT**

There is no fiscal impact related to advancing the proposed resolution expressing opposition to Initiative 2117.

**If you have a question related to the Council contingency fund request, please contact Christina Caan, Policy Analyst, at (253) 219-0679 (phone) or [ccaan@cityoftacoma.org](mailto:ccaan@cityoftacoma.org).**

SUBMITTED FOR COUNCIL CONSIDERATION BY: \_\_\_\_\_

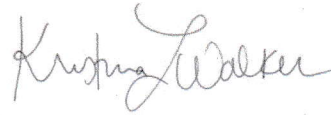

Council Member Kristina Walker

**SUPPORTING COUNCIL MEMBERS SIGNATURES**

1. \_\_\_\_\_



POS# 1

2. \_\_\_\_\_



POS# 7

Mayor's initials \_\_\_\_\_



**From:** Peter Jung <peterj2@uw.edu>  
**Sent:** Friday, August 2, 2024 11:54 AM  
**To:** City Clerk's Office  
**Subject:** Home in Tacoma Phase 2 Public Hearing

Hello,

My name is Peter Jung. I live in Central Tacoma, and am a lifelong resident of Tacoma, and an adult living with a disability who works with Pierce County's disabled population. A significant concern I see is that people with disabilities need transit support, and often live too far from transit for community living and medical care, which can cause significant life challenges. By having reliable access to transit, Tacoma's disabled community can engage with the larger community, rather than being isolated from contributing to Tacoma's vibrant city life.

I strongly support the Home in Tacoma Phase 2 zoning proposal as drafted by the Planning Commission, which aims to promote infill development in Tacoma's neighborhoods. As someone who relies in part on walking, biking, and public transportation for my daily needs, I believe these changes are essential to creating more livable, walkable, and sustainable communities, especially those living with disabilities.

By allowing for middle housing options, such as in the new Urban Residential zones, we can encourage developers to build a mix of market rate and affordable housing, reducing sprawl and preserving our city's unique character. This approach also aligns with Tacoma's goal of becoming a more inclusive and equitable community, by providing affordable housing options in close proximity to parks and schools, transportation options, medical and retail services, and employment opportunities. The inclusion of the Reduced Parking Areas near public transit is particularly exciting, as it acknowledges that not everyone needs or wants to own a car. Adding housing units near transit will give more people the option to walk out their front door and catch a bus or train to their destinations, reducing traffic and preserving our air quality while the city grows. By prioritizing pedestrian-friendly and bikeable design, we can create safer, healthier streets that benefit residents and visitors alike. The addition of walkable commercial in the UR-3 zones is bound to create interesting and unique opportunities for small businesses to thrive and for residents to have more things to walk to from home. Additionally, the proposed landscaping requirements will help maintain Tacoma's natural beauty, improve our adaptation to climate change, and promote community engagement through expanded green spaces and tree canopy. I appreciate the Planning Commission's thoughtful consideration of these elements and believe they will contribute to a more vibrant, connected, and sustainable Tacoma. Please pass Home in Tacoma to address the housing crisis and keep Tacoma affordable to live in.

Thank you,

--

Peter Jung M.Ed.  
(He/Him pronouns)

**From:** Steve Diamanti <steve.diamanti@yahoo.com>  
**Sent:** Sunday, September 1, 2024 8:29 AM  
**To:** City Clerk's Office  
**Subject:** Please vote no on Home in Tacoma Initiative

Dear City Council Members,

While I'm not anti-growth and realize we have a severe shortage of housing in Tacoma specifically and Western Washington in general, it's also very clear that the infrastructure in Tacoma is about 10 years behind its current population and is poorly suited to withstand further significant expansion. TPD is under resourced to protect and serve even the current population of Tacoma. Our city streets department is also woefully under resourced. I put in a request for a traffic study 240 days ago and it has yet to be actioned. Our streets are severely potholed and in a state of decay. What happens when traffic increases significantly due to increased population? Will the traffic engineers the city of Tacoma says they can't find magically appear. Will more folks suddenly develop an interest in being police officers to fill the openings that TPD currently struggles to fill and retain? Unlikely. Even worse is that many of these projects give massive tax incentives to corporate developers leaving the needed infrastructure improvements to be funded by guess who?

Sincerely,

Steve Diamanti,  
Tacoma resident

**Like**  
ReplyShare

Sent from [Mail](#) for Windows

**From:** Home In Tacoma  
**Sent:** Friday, September 6, 2024 2:32 PM  
**To:** City Clerk's Office  
**Subject:** FW: North End Resident HIT Concerns

For inclusion in Public Hearing packet to Council.

---

**From:** Jonathan Palinkas <jlpalinkas@gmail.com>  
**Sent:** Tuesday, August 27, 2024 4:19 PM  
**To:** Home In Tacoma <HomeInTacoma@cityoftacoma.org>  
**Subject:** North End Resident HIT Concerns

Hello,

I am a resident and homeowner living in Tacoma's Proctor neighborhood. I am worried the Home In Tacoma project is not listening to the resident's concerns. I am skeptical that much will be done to ensure the historic integrity of our existing homes and neighborhoods. There is also no mention about increasing more commercial /storefront space to promote local and small businesses. This should be a major priority. There are no commercial units to lease, what little units are available, the owners charge a premium. This is creating a brain-drain where we see all of Tacoma's young creative entrepreneurial talent exit for more affordable towns like Olympia and Port Townsend. I'm experiencing this firsthand as a millennial small business owner. I understand the HIT project is our opportunity to right this wrong, however I want to ensure these issues are addressed because I talk about this regularly with all my neighbors.

We also should provide city tax incentives for homeowners in these historic neighborhoods to register and designate their homes and neighborhoods so that our city does not turn into Capitol Hill. Capitol Hill in Seattle used to be a gem of the city, now it has giant units all over that no one can even afford. There is no tree canopy, high crime, high drug use on the streets, and no parking. What little historic integrity that is left is quickly being dissolved.

Constructing new large-scale units without respect to setbacks will only drive-up housing prices and prices out even more local residents. It seems practical to convert all the vacant buildings downtown into micro units to house all our city's houseless population. This is smarter than subdividing already tiny lots in neighborhoods like mine where parking is limited already. The city's houseless population should be the most top priority.

We should also consider local historic buildings like Cushman Substation as options to bring more housing into the North End specifically. There are so many vacant lots all around Hilltop and UW Tacoma that could benefit from more housing units immediately. The university is quickly growing and becoming a community gathering spot. We can have a better environmental footprint if we develop these lots smartly with higher mandates for affordable units.

I also want to convey the concern I have for the community as a whole. We need to ensure these new changes in zoning increase bike lanes, slow car traffic by increasing roundabouts, and allow more permanent street closures so the community can utilize the outdoor space. We should invest in our current parks and build housing around these areas like Jefferson Park and 6<sup>th</sup> Ave . It would be wise to allocate funds to construct more community centers that everyone can use together.

I come from a very dense part of San Diego and have served on the community planning board as representative to my Town Council. I know how importance the YMCA and other community centers are in these urban neighborhoods. If we have more of these with large community parking garages, we can reduce our street parking, have safer streets, and better communities.

Thanks for your time.

Best,  
Jonathan

Jonathan Palinkas  
[jlpalinkas@gmail.com](mailto:jlpalinkas@gmail.com)  
(858) 922-7258  
2409 N Washington St Tacoma, WA 98406



**From:** MaryAnn clabaugh <mclabaugh58@icloud.com>  
**Sent:** Friday, September 6, 2024 4:11 PM  
**To:** City Clerk's Office  
**Subject:** Home In Tacoma

Stop the insanity now! No one wants this to keep moving forward, yet ...you all continue to push it. The question is why?  
Sent from my iPhone

**From:** Jonathan Palinkas <jlpalinkas@gmail.com>  
**Sent:** Monday, September 9, 2024 1:33 PM  
**To:** City Clerk's Office  
**Subject:** Tacoma Resident Concern for HIT

Hello,

I am a resident and homeowner living in Tacoma's Proctor neighborhood. I am worried the Home In Tacoma project is not listening to the resident's concerns. I am skeptical that much will be done to ensure the historic integrity of our existing homes and neighborhoods. There is also no mention about increasing more commercial /storefront space to promote local and small businesses. This should be a major priority. There are no commercial units to lease, what little units are available, the owners charge a premium. This is creating a brain-drain where we see all of Tacoma's young creative entrepreneurial talent exit for more affordable towns like Olympia and Port Townsend. I'm experiencing this firsthand as a millennial small business owner. I understand the HIT project is our opportunity to right this wrong, however I want to ensure these issues are addressed because I talk about this regularly with all my neighbors.

We also should provide city tax incentives for homeowners in these historic neighborhoods to register and designate their homes and neighborhoods so that our city does not turn into Capitol Hill. Capitol Hill in Seattle used to be a gem of the city, now it has giant units all over that no one can even afford. There is no tree canopy, high crime, high drug use on the streets, and no parking. What little historic integrity that is left is quickly being dissolved.

Constructing new large-scale units without respect to setbacks will only drive-up housing prices and prices out even more local residents. It seems practical to convert all the vacant buildings downtown into micro units to house all our city's houseless population. This is smarter than subdividing already tiny lots in neighborhoods like mine where parking is limited already. The city's houseless population should be the most top priority.

We should also consider local historic buildings like Cushman Substation as options to bring more housing into the North End specifically. There are so many vacant lots all around Hilltop and UW Tacoma that could benefit from more housing units immediately. The university is quickly growing and becoming a community gathering spot. We can have a better environmental footprint if we develop these lots smartly with higher mandates for affordable units.

I also want to convey the concern I have for the community as a whole. We need to ensure these new changes in zoning increase bike lanes, slow car traffic by increasing roundabouts, and allow more permanent street closures so the community can utilize the outdoor space. We should invest in our current parks and build housing around these areas like Jefferson Park and 6th Ave . It would be wise to allocate funds to construct more community centers that everyone can use together.

I come from a very dense part of San Diego and have served on the community planning board as representative to my Town Council. I know how importance the YMCA and other community centers are in these urban neighborhoods. If we have more of these with large community parking garages, we can reduce our street parking, have safer streets, and better communities.

Thanks for your time.

Best,  
Jonathan

Jonathan Palinkas

jlpalinkas@gmail.com  
(858) 922-7258  
2409 N Washington St Tacoma, WA 98406

Jonathan Palinkas  
jlpalinkas@gmail.com

**From:** Sara Kiesler <sara.kiesler1@gmail.com>  
**Sent:** Monday, September 9, 2024 1:33 PM  
**To:** City Clerk's Office  
**Subject:** I strongly support the Home in Tacoma package and plans

Dear Tacoma Leaders and City Clerk,

I strongly support the Middle Zoning, Middle Housing, and Affordable Housing plans in the Home in Tacoma package. Tacoma is a great city known for its affordable housing, but unfortunately, too many people are struggling to pay rent or buy a home here right now. These tools will help make Tacoma a place we can all call home. Single family zoning is exclusionary and does not allow for the growth the city is experiencing.

My spouse and I are homeowners on a double lot in South Tacoma, adding a DADU or backyard dwelling to add affordable housing unit to the mix. Home in Tacoma makes that possible.

Sincerely,

Sara Kiesler  
5410 S Junett St, Tacoma, WA 98409

**From:** Mark perrow <perrowm@hotmail.com>  
**Sent:** Monday, September 9, 2024 4:01 PM  
**To:** City Clerk's Office  
**Subject:** Home In Tacoma - changes to parking on multiple family units.

### **Proposed Parking Requirements for HIT Implementation of reduced or no parking requirement for middle density housing.**

Zoning regulations should consider the impact of parking on fire response, emergency services, garbage collection, pollution runoff into Puget Sound, and the neighborhood's quality of life. HIT has not provided evidence that a similar policy has been implemented in another city similar to Tacoma without adversely impacting the current residents. HIT has not provided studies showing the percentage of individuals who can reach jobs using public transportation and the average time of commute using public transportation versus a private vehicle (justifying a high percentage of individual will not have private transportation).

HIT assumes that residents of middle-level housing within a half-mile of a transit hub will rely on public transportation and require limited to no vehicle parking. However, HIT's assumption that reduced parking will guarantee reduced housing cost for renters and purchasers is not supported by evidence. It is essential to protect current property owners and renters who may be affected by the implementation of reduced or no parking for new multi-residential units.

To ensure the protection of residents in impacted areas, HIT should include legislation to prevent overcrowding of residential neighborhoods. **If HIT's assumptions are correct**, the additional regulation should not be a problem since new renters will not have a vehicle. **If not**, current residents should have some protection against overcapacity and ensure that their friends, visitors, emergency vehicles, and utilities have adequate parking.

#### **Proposed Parking Requirements:**

1. Middle-level housing units with multiple units that rely on street parking will require a city of Tacoma-issued parking permit.
2. New middle-level or higher housing units without parking will be limited to one permit for two units.
3. Existing residents will be limited to two permits per unit.
4. Depending on the density of housing units, limited additional permits can be purchased for \$200 per month (subject to inflation adjustment) with a maximum of one per housing unit.
5. Vehicles parked on the street within the permitted area will be limited to two hours and will be ticketed for parking violations. Repeat offenders will be towed at the resident's expense.

**From:** Julie and Jay TURNER . . . . <juliejayturner@gmail.com>  
**Sent:** Tuesday, September 10, 2024 5:57 PM  
**To:** City Clerk's Office  
**Subject:** letter to each council member  
**Attachments:** Letter to Council .pages.pdf

Please send our letter to each Council Member, and the City Manager.

Thank you.

Julie Turner  
817 North J St.  
Tacoma, WA 98403

253-383-2329

Dear Council Member,

Will you please look carefully at the impact that this HiT2 will have on older neighborhoods that are already full and have no more building room available? Our neighborhood is already full and struggles to provide for more residents. We already have small apartment buildings and large ones, and have had them for years. We are one of the densest neighborhoods in town - if not the most dense. And, we just don't have room for more!

Since we placed an Historic Residential District on our neighborhood, we have stabilized our population and now have no room for more people. Apartments and single-family homes have filled the few vacant lot we had, and I doubt we have more than one or two left. We have difficulty providing parking for those living here and visitors have trouble parking on our streets; it would be nearly impossible for us to accommodate more apartment buildings than we already have.

We are among the densest of Tacoma's neighborhoods, and feel that more residents would compromise our quality of living. Please help us out by telling the Planners and the Planning Commission to revert to Hit1's changes - which still makes us one of Tacoma's densest neighborhoods. Even the State has more lenient guidelines than Hit2 has!

Please help us! We are FULL here in North Slope Historic District!

Julie Turner  
Jay R. Turner  
817 North J St.  
Tacoma, 98403

**From:** Ian Harding <harding.ian@gmail.com>  
**Sent:** Wednesday, September 11, 2024 8:35 AM  
**To:** City Clerk's Office  
**Subject:** Home In Tacoma (HIT) Zoning Standards Package

Hello!

I live in Tacoma and have for a while. My home would be impacted by the HIT zoning with a change to UR3. I have reviewed the documentation and the map and I think it's great. It's what zoning should be, encouraging density where it makes sense and using the levers of government to include counterbalancing environmental and historic preservation restrictions.

I don't know and I don't care what impact there will be on my home's assessed value or market value. I care that the City is taking steps to be more environmentally friendly and human friendly.

Keep up the good work.

Ian Harding  
Tacoma, WA



**From:** Jordan Thomas <j.g.thomas@live.com>  
**Sent:** Wednesday, September 11, 2024 7:51 PM  
**To:** City Clerk's Office  
**Subject:** Home in Tacoma Zoning

Please don't listen to the NIMBYs! Those who oppose any and all change are always the loudest voices in the room. I'm sure the council is well aware so this is more for my fellow Tacoma residents: single-family zoning is a huge source of problems in our cities.

A century ago, houses, businesses, multi-family residences, and apartment buildings sat side by side providing localized services and a small measure of economic integration. This created neighborhoods which had local services for residents and helped to enable social mobility by fostering interaction between people of different income levels. This wasn't perfect, of course, ethnic and racial segregation were rampant, for example. But over the course of the 20th century we have largely replaced that ethnic and racial segregation with economic segregation, one of the ways that happened was via strict, single-family zoning. The many side effects of this have included automobile reliance, food deserts, urban sprawl, urban decay, and the ongoing housing and homelessness crisis.

Enacting new zoning to bring back mixed neighborhoods is a step in the right direction that is long overdue.

Kind Regards

-Jordan

Tacoma resident and home owner

(Pronouns: he/ him)

**From:** Torrez, Alyssa  
**Sent:** Thursday, September 12, 2024 10:33 AM  
**To:** City Clerk's Office  
**Subject:** FW: Home in Tacoma Phase 2 Comments

HIT Public Comment for your records.

Alyssa

---

**From:** Planning <[planning@cityoftacoma.org](mailto:planning@cityoftacoma.org)>  
**Sent:** Thursday, September 12, 2024 8:47 AM  
**To:** Torrez, Alyssa <[ATorrez@cityoftacoma.org](mailto:ATorrez@cityoftacoma.org)>  
**Subject:** FW: Home in Tacoma Phase 2 Comments

fyi

---

**From:** Darin Lenderink <[darin@lenderink.org](mailto:darin@lenderink.org)>  
**Sent:** Wednesday, September 11, 2024 8:47 PM  
**To:** Planning <[planning@cityoftacoma.org](mailto:planning@cityoftacoma.org)>  
**Subject:** Home in Tacoma Phase 2 Comments

Change is hard. We purchased our home 30 years ago, and we have significantly reinvested in the property. We chose our home based on its location, existing zoning code, physical context (neighborhood), and affordability. Our children were raised here, and we had hoped to retire here.

We are proud to live in Tacoma even when coworkers questioned the city's reputation. We love the tree lined streets of our neighborhood. We love to walk our dog and visit with neighbors in our gardens. Our family has worked hard for this lifestyle and have worked hard to maintain our home.

Our first reaction to the Home in Tacoma planning efforts was the question: "How is this going to affect our neighborhood and our experience living in Tacoma?" We understand the need for more housing. But, how can that be done and still protect what makes Tacoma special? Once it is torn down, there is no going back.

After attending a few public meetings and briefly looking at the Environmental Impact Statement (EIS) and proposed code changes, we have a few concerns:

1. Properties on the Washington State's and the National Register might not have the same level of protection that Tacoma Register properties will receive. Listing on the state or national registers means the buildings have historic significates and should have local protections.

As noted in the EIS (4.7.2.6) there is a significant number of potentially eligible historic properties that have not been evaluated in the city. There is the potential for adverse impacts to these unidentified sections of Tacoma. Has the city, or should the city, complete a high-level evaluation to make sure significant cultural resources will not be lost to development?

2. With the reduction of automobile parking, does the city have any plans to improve bike pathways – lanes?

3. Will Tacoma become a land of renters with large Real Estate Companies and Trusts

owning more properties? How can the land use changes promote increases to home ownership for a family?

4. What is the definition of "Affordable Housing"? Does it mean affordability for every income bracket?

5. Will Property Tax reduction for new development impact existing taxpayers? Who will be paying the new residences/building owners share of related costs? How much of the tax burden will be placed on existing owners in Tacoma to cover costs of these new developments? While we are willing to pay more taxes to help a lower income family to be housed, we do not want to pad the profit of developers/real estate companies.

6. Can Design Standards be enforced if there is no design review?

Our family hopes the Home in Tacoma zoning changes and future redeveloped will not destroy the vibrant neighborhoods that already exist in the city. We hope new developments are done in a way that creates livable vibrant neighborhoods that are affordable for many. We hope developers will not demolish the historic homes in the city.

Kind Regards,

Darin and Kelly Lenderink  
520 North Cushman Ave.  
[darin@lenderink.org](mailto:darin@lenderink.org)

**From:** Kirsten Carlson <kcarlson3416@comcast.net>  
**Sent:** Thursday, September 12, 2024 5:25 PM  
**To:** City Clerk's Office  
**Subject:** Just say "no" to Home in Tacoma....

Councilmembers,

As a 30 year resident of the City of Tacoma, I am urging you to say 'no' to the Home-in-Tacoma (HIT) package as currently written. If enacted, the proposed changes will destroy the character and livability of our city. There will be no looking back and you will own the city's demise. House Bill 1110 should represent a ceiling, rather than a floor, to zoning changes in Tacoma.

Tacoma's unique neighborhoods should be celebrated and not destroyed. With a bit of creativity, we should be able to preserve (and improve) our neighborhoods and address affordability issues. Tacoma currently lacks the public works, public transportation, public safety and business infrastructure to support the density that HIT proposes and does not even address these issues. The following are my primary concerns with the proposed re-zone:

- Reduced tree canopy. Tacoma's tree canopy is sorely lacking and there is no way it can be enhanced with the density proposed by HIT. The city will become even more of a concrete jungle. Environmental concerns cannot be reconciled with the current HIT proposal;
- Proposed reduced parking is madness. The city planners may bike to work uphill in the rain but nobody else will. Most residents have a vehicle for each driving family member and this will not change just because city planners wish it;
- No design standards. Housing with no architectural value may be cheap to build but is a visual blight and will diminish the value of homes in established neighborhoods if they are allowed to be built;
- Proposed density is unfathomable. I live near UPS and my charming street would be re-zoned as UR2 under the current proposal. I can't even imagine how a developer could shoe-horn 12 units onto my lot but I can guarantee you it would ruin the aesthetic and historical charm of the street and there would be no room for trees;
- No guarantee that increased density will mean cheaper housing. Proctor has plenty of units and they represent some of the most expensive housing per foot in the city.

Instead of encouraging developers to ruin our city by cramming 21st century tenements into residential neighborhoods, why don't you spend some time trying to attract businesses that pay more than minimum wage? Affordability is personal, it has a different meaning for everyone. Instead of reaching for the bottom with HIT why aren't you trying to lift people up into better paying jobs? Councilmembers, we can do better than this proposal.

Stop the madness,  
Kirsten Carlson  
253-905-2127

Frankly, you are reaching for the bottom.

**From:** Michael <mmalaier@hotmail.com>  
**Sent:** Friday, September 13, 2024 10:03 AM  
**To:** City Clerk's Office  
**Cc:** Kirsten Carlson; Jess Kendrena  
**Subject:** "NO" on Home in Tacoma Phase 2

I am writing to register my opposition to the proposed Home in Tacoma Phase 2 zoning designations. Our neighborhoods (throughout the city, from north to south, east to west) have character that deserves protection. Allowing developers to erect 4 and 5 story apartments (much less with no design review as happened in Proctor) would destroy what makes our city so great: it's livability. Home in Tacoma should go no further than what Olympia mandated, which is, in itself, extreme.

To see that 5-story buildings will be permitted all along North 21st, with no required onsite parking and no design review, is distressing. Our infrastructure cannot support these drastic changes and there is simply no need for them. As of this morning, per apartments.com, there are 3100 available apartments in Tacoma city limits. The hastily-constructed complexes on Tacoma Avenue and downtown are half empty. So why is the council contemplating this massive giveaway to developers? From my reading of the proposed ordinance, these developers will not even have to pay mitigation fees for the deleterious impact they cause on our roads, rights of way, and utility infrastructure...Phase 2 simply cannot go forward.

Regards,

Michael Malaier  
3410 N 19th

**From:** Fred Dowell <freddowell54@gmail.com>  
**Sent:** Friday, September 13, 2024 2:37 PM  
**To:** Richardson, Ted; Hines, John; City Clerk's Office; Scott, Jamika; Diaz, Olgy; Rumbaugh, Sarah; Walker, Kristina; Daniels, Kiara; Bushnell, Joe; Sadalge, Sandesh  
**Subject:** HIT AKA HOME IN TACOMA

Dear Mr Richardson recently you were on one of the city of Tacoma TV shows and with another planner talking about the home in Tacoma and one comment that you made concerns me greatly and I want you to explain your comment with details

While you were talking about this you made the mention and I quote

"We need to give money to these developers so they can build this multifamily housing"

Please explain what money is you think we the taxpayers need to give the developers when they're already getting multi-family tax exemptions and we have to pay that out of our taxes

Plus we don't have any impact fees in this city and they've been dragging their feet on that for over 3 years supposedly in October they're going to address it

On a second issue in regarding parking for these new multi-families that you want to have the city be covered in

I believe you stated that if people live on a major route like route number two that goes from downtown all the way to TCC that developers won't have to provide ANY parking if you live up within a quarter mile of a main bus route.

Do you expect everyone to park their cars on a street Like Proctor Or what about some of the neighborhood streets that are narrow and if everybody's got to park on this street and they start parking on both sides It may not be wide enough for your emergency vehicles to get through

So I questioned in regards to this what are you going to expect people to do ride the bus walk or bicycle to a grocery store or a doctor's appointment? Would you do that Mr Richardson?

And then what's the next step you're going to decide that people that live on a street like that that has no parking off Street that you're going to require them to get a parking permit and then what's after that start charging for them to park on the street like they do in downtown Tacoma?

Personally I think your plans are way overboard and go much farther to want the state of Washington has in place and I think it's wrong and I'm probably too late cuz I hear on the 14th or whatever date you're going to have the a vote on this I think it needs to be delayed until this is reworked

And I mention you what about the other planner is she willing to live in a multi-family house on a near a street and either walk or bike or take the bus to downtown Tacoma to her job?

I wonder if any of the city council members already do this or they just drive down to the council chambers every day for meetings maybe all of you need to practice what you preach

I've seen some new buildings that have been built in neighborhoods that are so close to houses if there's ever a fire the house next door is going to be destroyed and they're so close to each other that you could stick your hand out your bathroom window and shake hands with your neighbor

I look forward to your reply

**From:** Torrez, Alyssa  
**Sent:** Friday, September 13, 2024 2:55 PM  
**To:** City Clerk's Office  
**Subject:** HIT Public Comment  
**Attachments:** UR-3 Zoning Request for Parcel Number 0320333241 (Property Address\_ 8839 Pacific Ave, Tacoma, WA 98444).pdf

Please see attached letter for the public hearing.

Thank you,



**Alyssa Torrez** (she/her)  
*Senior Planner*  
City of Tacoma – Long Range Planning  
747 Market Street, Room 345, Tacoma, WA 98402  
(253) 878-3767

Dmitry Lebed  
2571 152nd Ave NE  
Redmond, WA 98052  
Dmitry@EmeraldCityBuild.com  
425-495-3188

Date: September 5th, 2024

City of Tacoma Planning and Development Services  
Tacoma Municipal Building  
747 Market Street, Room 345  
Tacoma, WA 98402

Re: UR-3 Zoning Request for Parcel Number 0320333241 (Property Address: 8839 Pacific Ave, Tacoma, WA 98444)

Dear Larry and the City of Tacoma Planning Department,

I am writing to formally request that the property located at 8839 Pacific Ave, Tacoma, WA 98444, with parcel number 0320333241, be rezoned to UR-3 as part of the ongoing development process. I am working with Ferguson Architecture on this project, and we believe that rezoning to UR-3 will greatly benefit both the City and the community.

We are excited about Tacoma's \*Home in Tacoma\* initiative and the positive impact it will have on the city's growth. Given the property's location, we feel that a commercial development is not ideal for this site. Instead, residential development would better complement the surrounding area and fulfill the increasing demand for housing.

Thank you for considering our request. We look forward to continuing to work with the City of Tacoma to move this project forward.

Sincerely,  
Dmitry Lebed



**From:** Patricia Hodges <pdhodes3@q.com>  
**Sent:** Friday, September 13, 2024 4:40 PM  
**To:** City Clerk's Office  
**Subject:** Home in Tacoma Zoning

Council Members,

I was born in Tacoma and spent my early years here, then moved back permanently in 2006. I live 3 blocks from the Proctor business district, which I have watched balloon into a crowded, traffic-dense mess. Many of the charming shops and restaurants that used to have spaces here have been forced out due to high rent costs. The looming apartment buildings cause a canyon-like feel to an area that formerly had at most two-story structures. The Proctor District has had for decades what many cities strive for -- an area with businesses serving the surrounding residential population, where people can mostly walk to do their shopping and dining. I feel that the district's success is on the verge of being its undoing, that it will lose its convenient, neighborhood feel, with the push to cram in more and more people, cars and high-rise apartments.

I am not opposed to multi-family dwellings like duplexes, four- and six-plexes, ADUs and such. Those kinds of structures blend in nicely with this area of mostly single-family homes. I do fear that allowing up-zoning of an established neighborhood of single family homes will bring unwelcome changes. People love this area for its quiet, its convenience, its relative uniformity. Why would the city try to ruin a treasured part of Tacoma that is successful, that already works so well?

Please do not adopt the radical zoning changes proposed in Home in Tacoma.

Thank you,

Patricia Hodges

**From:** Nancy Westcott <ziptoy1731@icloud.com>  
**Sent:** Sunday, September 15, 2024 11:20 PM  
**To:** City Clerk's Office  
**Subject:** Home in Tacoma, Comment!

Do not pass the "Home in Tacoma" zoning changes. Instead, manage the zoning changes already made by House Bill 1110, passed by the Washington State Legislature in 2023!

I grew up here, stayed here, purchased a home here and raised my family and grand children here. I have no desire to live in places like Seattle, Portland, Los Angeles, New York, Chicago. I don't want Tacoma destroyed, there is a lot of vacant land that could be built on just out a ways from Tacoma and Busses 🚌 could make routs from those areas back and forth from housing there. And stop 🗳️ giving these builders big tax cuts to destroy our town.

Thank you for your time

Nancy L Westcott

Sent from my iPad

**From:** Torrez, Alyssa  
**Sent:** Monday, September 16, 2024 9:24 AM  
**To:** City Clerk's Office  
**Subject:** FW: HIT, upcoming hearing Sept 19

Please see comment for the Home In Tacoma Public Hearing.

Best,  
Alyssa

---

**From:** Michael Russell <michelrussel5555@gmail.com>  
**Sent:** Monday, September 16, 2024 9:11 AM  
**To:** Torrez, Alyssa <ATorrez@cityoftacoma.org>  
**Subject:** HIT, upcoming hearing Sept 19

Hi Alyssa,

I missed the Sept 12 hearing at City Council as I just got your mailing today, and I will not be able to make the September 19th hearing due to a prior engagement. I wanted to call to your attention a problem that I see with your proposed UR zones 1-3. I will focus on the zoning specifically as it relates to my family. I have been a Lowell Elementary neighbor since 1999 and we have gotten used to sharing our only parking access, on street, with our neighbors and the Lowell Community. However, parking has always been a challenge. Our immediate neighborhood has been primarily SFD in the view sensitive overlay. To cut to the chase, I propose changing the following area from UR2 VSO to UR1 VSO to account for the difficult parking situation adjacent to Lowell and St. Patrick's Elementary schools. Please consider UR1 VSO zoning for the Yakima 1200-1300 blocks and Carr street between Yakima and Tacoma Ave. I fear that making these UR2 which have only 0.75 parking per unit and 6 units per site has the potential to make it impossible to park near our home. I feel that the UR-1 designation allowing 1.0 parking per unit and 4 units per site would be a much better fit for preserving quality of life for myself and for my neighbors. Also, keep in mind that all of I street is on a proposed UR3 zone. Thanks in advance for your consideration.

Sincerely,

Michael Russell  
1308 N. Yakima Ave  
Tacoma, WA 98403  
253-686-5785

**From:** Sharon Styer <sharon@sharonstyer.com>  
**Sent:** Monday, September 16, 2024 12:47 PM  
**To:** City Clerk's Office  
**Subject:** HIT

Dear Mayor, City Manager, and Council Members; The escalation of rezoned residential areas- primarily in the North End- and the change to the buildings allowed is alarming.

HIT is aptly named as this is what you are bringing to Tacoma. To be honest, single family homes are what people want. Your pretense that this rezoning is "to help the low income" is false. Pricing on the new construction is too high for low income. Just look at that monstrosity on 6th, The Gage.

If HIT were truly towards needed affordable housing then more of South Tacoma would be rezoned.

We know that profits for developers lie in jamming as many dwellings as possible into the smallest allowable space. The changes you are ready to approve hands developers the power and justification to do this.

HIT will be your legacy. Make sure this is how you want to be remembered. Not as a Council that provided homes for modest income families, but as a Council who caved to developers and changed the housing landscape of Tacoma for the worse.

Sincerely,  
Sharon Styer.

**From:** mike elliott <mike\_elliott99@hotmail.com>  
**Sent:** Monday, September 16, 2024 4:48 PM  
**To:** City Clerk's Office  
**Cc:** mike elliott  
**Subject:** Written Comments; Home in Tacoma Zoning & Standards package  
**Attachments:** Comments\_HIT\_Zoning&Standards\_16September2024.pdf

Dear City Clerk,

Please find attached my written comments concerning the Home in Tacoma Zoning & Standards package. Please confirm you have received my comments.

Thank you,  
Mike

Date: September 16, 2024

To: Tacoma City Council

From: Mike Elliott

RE: Home in Tacoma Zoning and Standards Package, as recommended by the Tacoma Planning Commission.

To Whom It May Concern:

I am a Tacoma resident and live in the West End Neighborhood Council (WENC) area. I have followed Home in Tacoma (HIT) for over a year, participated in the WENC discussions involving HIT, and provided input to city planning staff at the HIT open house at Silas High School earlier this year. Unfortunately, my concerns and those of many other residents living in the WENC area have been ignored.

First, I agree more affordable housing is needed EVERYWHERE. However, HIT is NOT the answer. The concept has been forced onto citizens with their input and recommendations being ignored. A prime example is the 33<sup>rd</sup> Street development (see Application SDEV23-0030). In the case of the 33<sup>rd</sup> Street development, I and many other concerned citizens pointed out the serious public safety shortcomings during public commenting opportunities under both the planning and permitting stages of the development. Guess what? Those comments went in one ear and out the other at Tacoma Planning and Permits.

One of the most glaring safety concerns never addressed was the intersection of 33<sup>rd</sup> Street & Pearl Street. The developers, not the public, should have been saddled with improving safety at that intersection for both pedestrian and vehicle traffic attempting crossing and merging activities. But as it stands today, neither the developers nor the city has taken steps to add the infrastructure necessary for public safety. FYI, I hired a professional traffic engineer, with 40+ years of experience to testify at a hearing before the Tacoma Hearing Examiner. The expert testified as to the need for additional public safety traffic improvements at 33<sup>rd</sup> Street & Pearl. But the city defended the planning department's poor decision and allowed the permitting package to advance without adding safety measures at the 33<sup>rd</sup> Street & Pearl Street intersection. Not even the most basic, cost-effective safety improvements, i.e. painted crosswalks and a turn lane extension, were approved by the City of Tacoma. Unfortunately, and needlessly, it is only a matter of time before someone loses their life at the intersection of 33<sup>rd</sup> Street & Pearl because the City of Tacoma refused to listen to Tacoma residents who live, work, and travel these neighborhood streets every day.

As for comments regarding the HIT Zoning and Standards package as recommended by the Planning Commission – it is insufficient, incomplete and should not be approved by the City Council. The WENC has spent many hours listening to residents and contemplating how to best move forward with more housing density in the West End

Neighborhood. Safe, sane, and sensible planning and permitting have been part of the WENC discussion from Day-1. If you have not seen or read the WENC recommendation regarding the HIT Zoning and Standards package, I have included them below:

**WENC Recommendations for HIT Zoning and Standards Package**

- 1. Lower the density levels by merging UR-2 into UR-1. UR-2 uses a misguided view of access to justify mid-level density in our neighborhoods, something that was soundly rejected in Phase 1.**
- 2. Limit density in a merged UR-1 and UR-2 to no more than the state-mandated 4 housing units plus 2 affordable bonus units.**
- 3. Limit density in UR-3 to the standards that you have labeled as UR-2.**
- 4. Retain deep and wide setbacks and 25' height restrictions that were used for residential zoning before Home in Tacoma.**
- 5. Require design standards in terms of scale and architectural style to ensure new buildings are compatible with neighborhood patterns.**
- 6. Strengthen tree canopy requirements to ensure that developers don't opt out.**
- 7. Require at least one designated parking space per housing unit.**
- 8. Ban shipping containers for housing and residential storage.**
- 9. Require developers to pay all impact fees.**

I agree with the WENC recommendations with one exception: Developments should have a minimum of two (2) parking spaces per housing unit. Today, young people share apartments, have more than one motor vehicle, work more "gig" jobs rather than "9-5" jobs, and travel from job-to-job in one a workday more than ever before. Invariably, each building has at least two, and sometimes more, vehicles per housing unit. One parking space per housing unit is insufficient and developments should not be approved without a minimum of two "on-site" parking spaces per housing unit.

These are my recommendations for the HIT Zoning and Standards package.

Mike Elliott  
3301 N. Shirley Street  
Tacoma 98407

**From:** Alisa Henke <alimarhen@aol.com>  
**Sent:** Monday, September 16, 2024 9:10 PM  
**To:** City Clerk's Office  
**Subject:** Home In Tacoma

Thank you for mailing me a "Notice of public Hearing" on the Home in Tacoma topic.

I have lived in Tacoma for 55 years.(9/23/69). I am also a homeowner of 2 homes. One on the Eastside, and one on the South End of our city. Unfortunately, I am opposed to the proposed re-zoning of our city to make way for more growth. Our city is already overcrowded. One important reason that is very concerning, is not having enough doctors for overall healthcare. Myself and many others who try to make a doctor's appointment, are MONTHS away from being able to be seen by a doctor. It is even worse for mammogram scheduling. The main reason doctors are so backed up in scheduling is because we have too many people in our city already. Another huge concern is emergency vehicles not being able to find the site of the emergency if homes are compiled behind one another and/or too close together to get to the correct destination of the emergency. I believe that both of my concerns make good sense. Again, thank you for this opportunity to address my concerns. Alisa Henke  
Sent from my iPhone



**From:** Zachary Cohen <znchome@gmail.com>  
**Sent:** Monday, September 16, 2024 9:28 PM  
**To:** City Clerk's Office  
**Subject:** Support of the Home in Tacoma Zoning and Standards package

Hello City Clerk and Council,

As a resident of Stadium District, I am writing in strong support of the Home in Tacoma Zoning and Standards Package that will be considered at the September 24th city council meeting. The years of work that have gone into this piece of legislation have paid off, and I believe if implemented, it will bring some necessary changes to our community to help ease the affordable housing crisis. I hope that the council will consider the many working families, renters, and young residents like myself who are struggling to afford to live in their homes in Tacoma, and will pass this legislation, so we can continue to call Tacoma home.

Sincerely,  
Zachary Cohen  
226 Broadway Apt 20  
253-285-8783

**From:** Scott Wagner <swagner@narrowsmarina.com>  
**Sent:** Tuesday, September 17, 2024 10:07 AM  
**To:** City Clerk's Office  
**Subject:** Comments To City Council On Implementing Phase 2 Of Home In Tacoma

Dear Tacoma City Council,

As a business owner and 64 year resident of Tacoma, I'm writing to discourage you from implementing Phase 2 of Home In Tacoma without changes. I would like to see you direct staff to manage the zoning changes already made by House Bill 1110 prior to enacting Phase 2. Phase 2 is not the way I want to see the Tacoma I love developed. Slowing it down and better protecting existing neighborhoods is more important than implementing a plan that will change the feel of the City for many years to come.

Respectfully,

*Scott Wagner*

**Narrows Marina LLC**

9007 S 19<sup>th</sup> St, Suite 100  
Tacoma, WA 98466  
(253) 564-3032

This email message may contain confidential and privileged information. Any unauthorized use is prohibited. If you are not the intended recipient, please contact the sender by reply email and destroy all copies of the original.

**From:** Lynn Di Nino <lynndin@msn.com>  
**Sent:** Tuesday, September 17, 2024 12:49 PM  
**To:** City Clerk's Office  
**Subject:** Home in Tacoma letter

Hello staff who propose new zoning for Tacoma,  
I am 79 years old living in my house in Old Town which happens to be on a double lot. I see that you'd find a better use for my property if there were eight units.

I was 'forced' to sell my Seattle home due to upzoning in 2001. My taxes literally doubled overnight, which I could not afford. I understand that it is 'unknown' if this rezoning will affect my property value. . . .

Also, I see that the proposed zoning comes with half a parking spot per unit. Are you aware that there IS NO public transportation in Old Town? NO buses.

Please consider maintaining the character of the 'quaint' Old Town neighborhood by not adding boxes of housing units. On top of everything else, I understand Tacoma has no design review for proposed housing.

I wish I could come to the meeting but will be out of town. Thank you, Lynn Di Nino, 2313 N 29<sup>th</sup> St. Tacoma 98403. . .

**From:** Brenda Loomis <loomisbrenda6@gmail.com>  
**Sent:** Tuesday, September 17, 2024 3:49 PM  
**To:** City Clerk's Office  
**Subject:** Public hearing written comments

Environmental impact

Police dept more demand safety hire more police Fire dept hire more demands building homes to close to road or neighbor  
Garbage dept home trash street people Environmental service water issue drainage water piping sewer dept Public school  
system over crowded need more education support Community safety crime property tax help pay for these dept with all  
these homeless buildings hud apts how and where are funds to cover city expense water sewer police fire Parking limited  
already Road maintenance sept city road need work now not maintained properly and more traffic stop enabling people there  
going store stealing vandalism cars no accountability everyone lived in state entire life is impacted my ins rates higher because  
of crime food prices high due to theft a bunch of animals impact our city our state drug programs are needed praying on kids  
vending machines in library s narcan in schools to when are you going to stop the insanity just going in circles

Brenda loomis  
Tacoma wa

Sent from my iPhone

**From:** Tami Jackson <tamijackson@gmail.com>  
**Sent:** Wednesday, September 18, 2024 8:51 AM  
**To:** City Clerk's Office  
**Subject:** Please do NOT pass the Home in Tacoma zoning changes!

I've lived in Los Angeles and the way Tacoma planners want to limit parking available to newly constructed apartment units is alarming. They're trying to turn Tacoma into L.A. (where everyone is forced to park on the street, resulting in higher property and vehicle crimes and disgruntled homeowners begin having conflict with strangers who park in front of their homes).

Keep the vision of House Bill 1110 (passed by the Washington Legislature in 2023) in front of you! Let that bill guide you so Tacoma does not become a horrific ghetto.

Signed by a concerned citizen,  
Tami Jackson

**From:** Torrez, Alyssa  
**Sent:** Wednesday, September 18, 2024 9:36 AM  
**To:** City Clerk's Office  
**Subject:** FW: Housing in tacoma

Please see below comment for the public hearing.

Best,  
Alyssa

---

**From:** Ilona Houston <ijhouston1943@gmail.com>  
**Sent:** Tuesday, September 17, 2024 4:23 PM  
**To:** Torrez, Alyssa <ATorrez@cityoftacoma.org>  
**Subject:** Housing in tacoma

I live in the tacoma area hilltop and have seen housing apt that have been build in our area at a very fast base neighbors concern about robbers and stores moving our of our atea. We have 3 large apartment building in one block in one area I am thinking for the homeless. I have had my car broken into 3 times by the homeless what will happen when they start living in the neighbor. Yes we will be at any meeting concern any more housing in our neighbor

**From:** Mary Ann Clabaugh <mclabaugh58@gmail.com>  
**Sent:** Wednesday, September 18, 2024 1:34 PM  
**To:** City Clerk's Office  
**Subject:** Home in Tacoma Comments

I'll keep this short. Stop moving forward with the Home In Tacoma plan, and everything about Pierce transit that goes with it .....stop now you're ruining our town.

**From:** Jim Marion <the3rdpigshouse1@aol.com>  
**Sent:** Wednesday, September 18, 2024 6:13 PM  
**To:** City Clerk's Office  
**Subject:** Home in Tacoma Zoning

Tacoma City Council,

I was born and raised in Tacoma, served 20+ years in the U.S. Navy, lived in several other countries, & finally returned/retired in Tacoma. I have witnessed the decay of what was once a terrific city as a result of poor government, an irresponsible legal system, & citizen apathy. I have worked successfully with safe streets in an effort to better my community with positive results.

I have enough history/experience in life within and out of Tacoma & feel justified in my position regarding the HIT Program. The HIT Program is an attempt to solve the problems associated with the economically disadvantaged elements in our society. Many of the problems associated with housing availability are further complicated by irresponsible government regulations & costs associated with home building. I see no movement to reduce the costs to the home builder or homeowner or, improving the availability of living wage employment in the Tacoma area in order to become a homeowner.

Along with homeowner costs there was once a "livability" criterion in planning housing developments. Zoning that allowed space to enjoy one's home and have reasonable space to enjoy family gatherings was a part of the plan. The current mentality is to build as many housing units as possible that the property can facilitate with little thought to the livability of the development. Increasing the home population with its added burden to public transportation, health care facilities, traffic congestion, and utility services overload have been given minimal consideration. The HIT Program will result in more taxes collected by government through increasing housing density. The HIT Program is another misguided government program destined to fail (e.g. the Tacoma BRT Program). There are special needs people in our society, and they must be cared for however, the majority are capable of earning their place in our city without sacrificing residents' quality of life!

Sincerely

James (Jim) Jones  
253-307-4509



**From:** Caroline Woodhams <linamwood@gmail.com>  
**Sent:** Thursday, September 19, 2024 12:53 PM  
**To:** City Clerk's Office  
**Subject:** Home in Tacoma

I am a 34 year resident of the North Slope. I strongly urge you to protect the historic heritage of our district. It showcases the architectural and human use heritage of our city and once gone it can never be replaced. Please keep in mind that we are also an excellent example of a dense neighborhood (one of the densest in Tacoma) that has successfully combined single family homes with multiple family dwellings while at the same time keeping its character because of the protections of being a National Historic District. We are worth protecting!!

Respectfully,  
Caroline Woodhams  
620 N M St.

**From:** Chris Karnes <chris.tacoma@gmail.com>  
**Sent:** Thursday, September 19, 2024 4:21 PM  
**To:** City Clerk's Office  
**Subject:** Home in Tacoma Phase 2 - Retain the Reduced Parking Area

Mayor Woodards and City Councilmembers-

My name is Chris Karnes. I am a proud resident of Central Tacoma and Hilltop. I have had the honor of serving on the Planning Commission since 2019 as an appointee in the Public Transportation seat, where I have sought to connect the dots between the City's land use planning and transit projects and services at Pierce and Sound Transit. I urge you to support the Home in Tacoma Phase 2 middle housing package, especially its focus on increasing housing density along our three principal transit corridors: Pacific Avenue, S 19th Street, and 6th Avenue.

## TACOMA'S AFFORDABLE HOUSING TARGETS

		Permanent Housing Needs by Income Level (% of Area Median Income)							Emergency Housing Needs (Beds)	
		Total	0-30%		>30-50%	>50-80%	>80-100%	>100-120%		>120%
			Non-PSH	PSH *						
Tacoma	Est. Supply (2020)	92,310	4,806	255	9,574	35,970	17,418	9,633	14,654	1,118
	Allocation (2020-2044)	42,865	5,538	7,483	7,949	6,283	2,705	2,452	10,455	2,624



Pierce County projects that by 2044, Tacoma will need close to 10,000 additional housing units for households making between 30-50% AMI. Home in Tacoma directly addresses this urgent need by enabling the development of diverse housing options close to transit, especially in the UR-2 and UR-3 zones. This means more accessible living choices for seniors looking to downsize, college students seeking affordable housing near campus, working families needing space and affordability, and individuals with disabilities who desire independent living within reach of essential services.

By reducing reliance on cars through increased density along transit corridors, we can create a more sustainable city. Imagine families being able to easily walk or bike to parks and schools, seniors easily accessing medical appointments via bus, and young professionals choosing not to own a car due to convenient transportation options. Home in Tacoma makes this vision possible.

Without reduced parking requirements along transit, Home in Tacoma, as a market-based reform, is generally limited to supporting housing options for households making more than 50% AMI. With reduced parking requirements near transit, housing savings can be combined with transportation savings to make these reforms more effective for the people who need not just affordable housing anywhere but housing that can put daily needs within reach. It is the intent of this policy to provide opportunity to those households making less than 50% AMI to afford housing in Tacoma without additional public subsidies, which are already stretched thin.

While some may express concern about parking availability, reducing requirements enables the development of more housing and frees up valuable space for green infrastructure like trees in Central Tacoma, which only has 15% tree canopy out of a 30% coverage goal. The State has provided much of the framework for these aspects of Home in Tacoma, with HB 1110 recognizing the benefit of reduced parking for housing affordability by mandating the elimination of parking minimums for residential buildings near high-capacity transit, and with SB 6015 further mandating that when requirements conflict, tree preservation

should take precedence over requirements for parking spaces.

The Planning Commission unanimously recommended including Pacific Avenue, S 19th Street and 6th Avenue in the Home in Tacoma Phase 2 Reduced Parking Area, recognizing the potential to accommodate growth while enhancing neighborhoods. This forward-thinking approach is vital to address Tacoma's housing crisis and to build a more equitable future. I urge you to approve the Home in Tacoma Phase 2 package with the expanded Reduced Parking Area as recommended by the Planning Commission.

I believe this package is essential for creating a more equitable and sustainable future for our city, and I trust you will support it.

Thank you for your time and attention.

Chris Karnes  
1416 S 8th Street  
Tacoma, WA 98405

**From:** Garrett Reim <garrett.reim@gmail.com>  
**Sent:** Thursday, September 19, 2024 4:29 PM  
**To:** City Clerk's Office  
**Subject:** Support for Home In Tacoma

I am a homeowner in West Tacoma and offer my full support for the Home In Tacoma rezoning initiative. The old policies of building restrictions and rent price controls have failed. We need to increase the housing supply to meet the demand and alleviate high housing costs, especially as the housing shortage ripples downstream and pushes low income people into homelessness. If any changes are made to downsize the Home In Tacoma initiative I would be very disappointed and inclined to speak out against and vote against the council member who made the changes. If anything, I hope you raise the height limits and building densities beyond what is prescribed in Home In Tacoma, especially for urban places like downtown Tacoma.

Please do not take loud and unreasonably angry NIMBYs as representing the voice of this community. I know many of my fellow Tacomans feel the same way and support Home In Tacoma.

Best,

Garrett Reim  
(253)651-8361

**From:** D Golding <d.b.golding@gmail.com>  
**Sent:** Thursday, September 19, 2024 5:27 PM  
**To:** City Clerk's Office  
**Subject:** Home in Tacoma feedback

I am a homeowner in Tacoma and I would like to see more housing built and available for our city. The price of housing is still too high and without more supply prices will still just keep going up.

My kids tell me they would like to live in Tacoma someday so this also matters to me personally.

Thank you  
Dustin Golding  
98405

**From:** Eric Peters <eric.peters206@gmail.com>  
**Sent:** Thursday, September 19, 2024 11:49 AM  
**To:** City Clerk's Office  
**Subject:** Written Comment on Home in Tacoma Public Hearing

Dear city clerk,

I am unable to attend the public hearing on September 24th but would like to submit the following as a written comment:

I live in Tacoma with my wife and small children where I own a house that will be rezoned into UR-2. I think this is a great thing for Tacoma and will do great things to increase affordability. With an increase of affordability, I hope we can also see increases in walkability, community, safe streets, and vibrant, diverse people. Housing affordability is key to fighting homelessness and is critical to making sure Tacoma does not become like Seattle. I recommend that the city council pass this HIT package. Thank you.

Eric Peters

**From:** Felicity Devlin <felicitydevlin@yahoo.com>  
**Sent:** Friday, September 20, 2024 10:00 AM  
**To:** City Clerk's Office  
**Subject:** Comments for Home in Tacoma  
**Attachments:** Comments for Home in Tacoma Sept 2024.pdf

Please find my comments for Home in Tacoma attached; they are also written below.

Thank you

Comments for September 24th Public Hearing on Home in Tacoma

From: Felicity Devlin

Date: September 10th, 2024

Dear Council Members,

I ask Council to vote No on Home in Tacoma. I know this program started out with good intentions aimed at housing affordability. However, it will not create affordable housing. Instead, it will create irreparable disruption for certain neighborhoods.

I'm particularly concerned that the City is planning to implement a program that seems inspired by the YIMBY movement from California. This movement was not spurred by the need to create affordable housing; rather, it was motivated by a desire to open up neighborhoods for development, especially development catering to more affluent residents. While it can wrap itself in the appealing language of "density," "affordability," and "middle housing," at root this drive toward massive zoning deregulation is nothing more than a libertarian stratagem. Similarly, while Home in Tacoma will not bring us affordability, it will open up opportunities in those districts that are most desirable to developers. The costs, however, will be borne by existing residents.

Many other commenters have highlighted the host of unintended consequences likely to arise from HiT: the strain on infrastructure and amenities, unavoidable loss of mature trees, inevitable displacement of existing residents, loss of historic structures. I am particularly concerned about the threat of serious disruption to established neighborhoods.

The huge differential between the scale of development allowed in the different UR zones will lead to marked inequity between neighborhoods, creating winners and losers: Some neighborhoods are now destined to change significantly; others will be left untouched. Neighborhoods where development is limited will become more sought-after by home buyers; while neighborhoods close to arterials and MUCs will lose value as the areas they adjoin become more crowded, more highly-trafficked and noisier (as forecast in the Planning Department's description of the areas slated for greater density).

Obviously change will not happen everywhere all at once. But uncertainty is now coming to the majority of our neighborhoods. Tacoma does not need to embark upon this dangerously unpredictable path, which, once started down, will be incredibly hard to reverse. We have enough buildable lands, we have areas already zoned for middle housing, we have a downtown crying out for further urban renewal, and we have the wide range of new housing types allowed in all neighborhoods from the zoning changes of HB 1110.

Our City staff and resources are already stretched thin. The City should focus on managing all the many changes that are already inevitable. Please do not pass Home in Tacoma.

Thank you for your consideration of my comments,

Felicity Devlin

Comments for September 24th Public Hearing on Home in Tacoma  
From: Felicity Devlin  
Date: September 10th, 2024

Dear Council Members,

I ask Council to vote No on Home in Tacoma. I know this program started out with good intentions aimed at housing affordability. However, it will not create affordable housing. Instead, it will create irreparable disruption for certain neighborhoods.

I'm particularly concerned that the City is planning to implement a program that seems inspired by the YIMBY movement from California. This movement was not spurred by the need to create affordable housing; rather, it was motivated by a desire to open up neighborhoods for development, especially development catering to more affluent residents. While it can wrap itself in the appealing language of "density," "affordability," and "middle housing," at root this drive toward massive zoning deregulation is nothing more than a libertarian stratagem. Similarly, while Home in Tacoma will not bring us affordability, it will open up opportunities in those districts that are most desirable to developers. The costs, however, will be borne by existing residents.

Many other commenters have highlighted the host of unintended consequences likely to arise from HiT: the strain on infrastructure and amenities, unavoidable loss of mature trees, inevitable displacement of existing residents, loss of historic structures. I am particularly concerned about the threat of serious disruption to established neighborhoods.

The huge differential between the scale of development allowed in the different UR zones will lead to marked inequity between neighborhoods, creating winners and losers: Some neighborhoods are now destined to change significantly; others will be left untouched. Neighborhoods where development is limited will become more sought-after by home buyers; while neighborhoods close to arterials and MUCs will lose value as the areas they adjoin become more crowded, more highly-trafficked and noisier (as forecast in the Planning Department's description of the areas slated for greater density).

Obviously change will not happen everywhere all at once. But uncertainty is now coming to the majority of our neighborhoods. Tacoma does not need to embark upon this dangerously unpredictable path, which, once started down, will be incredibly hard to reverse. We have enough buildable lands, we have areas already zoned for middle housing, we have a downtown crying out for further urban renewal, and we have the wide range of new housing types allowed in all neighborhoods from the zoning changes of HB 1110.

Our City staff and resources are already stretched thin. The City should focus on managing all the many changes that are already inevitable. Please do not pass Home in Tacoma.

Thank you for your consideration of my comments,

Felicity Devlin



**From:** Cory Joseph <washingtoncoryjoseph@gmail.com>  
**Sent:** Friday, September 20, 2024 1:04 PM  
**To:** City Clerk's Office  
**Subject:** Ordinance #28793

This type of zoning is only bringing more crime to good single family neighborhoods. I am totally opposed of this and Tacoma's City council trying to pack us into a sardine can and create more crime than they already have. As the citizens survey says, they can't handle the amount of crime they have created in the first place. Thank you.

**From:** THOMAS CLINE <clinetg@comcast.net>  
**Sent:** Friday, September 20, 2024 1:41 PM  
**To:** City Clerk's Office  
**Cc:** Jane Evancho; mike & nancy fleming; Constance Hoag  
**Subject:** Home In Tacoma - Ground Slope (percent) map, No to UR 2 zoning around the "Gultch"  
**Attachments:** IMG\_2643.jpg

Dear Tacoma City Council Members

Please read my email below to Elliott Barnett (dated 2/17/24) where I call out my concerns for the stability of our lot (address is 7535 S. Hegra Rd) and our neighbors lots surrounding the "Gultch". Most of the UR 2 designations have been changed to UR 1 on the current HIT map with the exception of Parcel #s 6235000140,6235000130,6235000120, 6235000110, 6235000090,6235000080, and 6235000062.

I have attached a photo of Exhibit "B" Ground Slope (percent), a document from the city of Tacoma, that was used in the Tacoma View Sensitive District Overlay-Node 1 approval process.

You will note on the map that around the "Gultch" the ground slope (percent)is between 15 to 25+ (25+ is in red).

Please do not zone UR 2 on any parcel located on Vista Dr. Multiple units on a sloped lot would require additional impermeable surfaces resulting in increased water runoff. More water runoff will increase slope instability and the ground slope (as stated in your map) will not support safe multiple living units. I do not want a version of the Oso landslide here in Tacoma.

I appreciate your attention.

Gail Cline

----- Original Message -----

From: THOMAS CLINE <clinetg@comcast.net>  
To: ebarnett@cityoftacoma.org  
Cc: john.hines@cityoftacoma.org  
Date: 02/17/2024 7:14 AM PST  
Subject: Geo tech Buffer in Narrowmoor 1

Hello Elliot

I was not able to attend the meeting on Wednesday when the new changes to the HIT map were shared and discussed.

You and I had discussed your previous city role where you had identified the lots in the "Gultch", now 7704 6th Ave & 7702 6th Ave, as a green erosion buffer that would retain a tree canopy.

Over the course of the development of the said lots, there were numerous tree removal violations that I witnessed and worked with Scott Haydon, Rebecca Sutherland and Allison Cook. If you drive by the "Gultch" now you will see that very few of the trees that supported the hillside remain.

The Oso landslide was mentioned multiple time as an example of what the City staff did not want to see happen to the neighbors surrounding the "Gultch". The violations issued and stop work orders in 2022 in the "Gultch" were to protect all of the abutting neighbors from a loss of property/housing.

I now see from the updated HIT map that we, along with the other neighbors surrounding the "Gultch", are in jeopardy of a landslide with the new HIT change to UR2. These adjacent lots cannot support up to 6 units. They cannot support any additional units period. The proximity to Geiger is moot if the land cannot support additional development and we have the City erosion buffer to protect.

Side Note: The large fir trees that are located on the Anderson's lot, parcel#6235000040 are critical to the support of the hillside and are also a sanctuary for the two bald eagles which roost on those trees almost daily during the current mating season and throughout the year. If you need photos of the eagles please let me know and I can text them to you.

The City is making a critical error in changing the zoning to UR2 in any area Narrowmoor.

Next steps Elliot?

I would appreciate your help.

Thank-you

Gail Cline

Tacoma View Sensitive District Overlay - Node I

EXHIBIT "B"

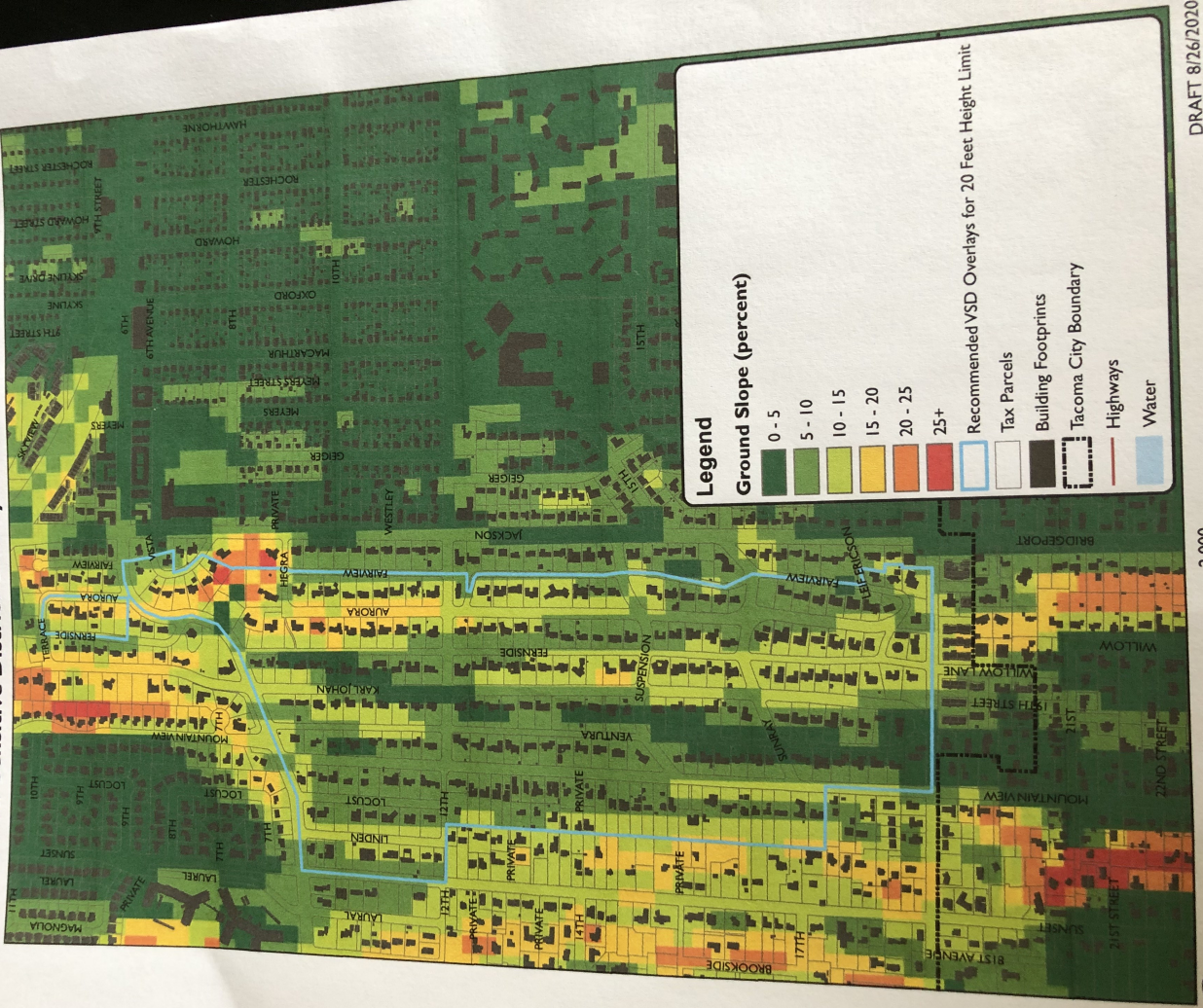

**Legend**

**Ground Slope (percent)**

- 0 - 5
- 5 - 10
- 10 - 15
- 15 - 20
- 20 - 25
- 25 +

Recommended VSD Overlays for 20 Feet Height Limit

- Tax Parcels
- Building Footprints
- Tacoma City Boundary
- Highways
- Water

DRAFT 8/26/2020

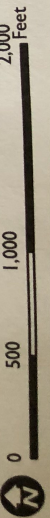

**From:** Cynthia Bertozzi Turco <cbturco@we-tacoma.org>  
**Sent:** Friday, September 20, 2024 3:36 PM  
**To:** City Clerk's Office; Daniels, Kiara; Diaz, Olgy; Walker, Kristina; Hines, John  
**Cc:** Vice Chair; Dennis Munsterman  
**Subject:** WENC's Comments for Home in Tacoma Public Hearing

As the full elected Board of the West End Neighborhood Council, we urge you to reject the Home In Tacoma Phase 2 proposal in favor of a less extreme plan.

Amended Ordinance 28793 had no mandate. It passed due to a patchwork of compromises and promises. As we review the Phase 2 plan, we realize that compromises were thrown out and promises were broken. The proposed plan is overreaching. It exceeds the intent of Amended Ordinance 28793 and the state legislative mandate. Please vote for a moderate plan.

#### Our Recommendations

1. Lower the density levels by merging UR-2 into UR-1. UR-2 uses a misguided view of access to justify mid-level density in our neighborhoods, something that was soundly rejected in Phase 1.
2. Limit density in a merged UR-1 and UR-2 to no more than the state-mandated 4 housing units plus 2 affordable bonus units.
3. Limit density in UR-3 to the standards that you have labeled as UR-2.
4. Retain deep and wide setbacks and 25' height restrictions that were used for residential zoning before Home in Tacoma.
5. Require design standards in terms of scale and architectural style to ensure new buildings are compatible with neighborhood patterns.
6. Strengthen tree canopy requirements to ensure that developers don't opt out.
7. Require at least one designated parking space per housing unit.
8. Ban shipping containers for housing and residential storage.
9. Require developers to pay all impact fees.

#### Points to Consider

1. The state legislature's zoning plan for the entire state means that a reduced burden has been placed on Tacoma.
2. The Growth Management Act requires periodic review and provides for modification if the burden becomes too heavy for urban areas.
3. The city's population figures seem inflated, given long-term trends and recent demographic shifts.
4. The populations of Portland and Minneapolis have dropped (despite upzoning) due to quality-of-life issues.

Respectfully,

Cynthia Bertozzi Turco, Chair  
Janice Fikse, Secretary  
Dennis Munsterman, Treasurer

**From:** Heather Carawan <heather@heatcar.com>  
**Sent:** Friday, September 20, 2024 8:42 PM  
**To:** City Clerk's Office  
**Subject:** Public Comment in favor of Home in Tacoma Phase 2

**I am borrowing this language from the Tacoma Tree Foundation because it summarizes the thoughts I have about the importance of trees in our community. And the importance of trees directly supports the health of our people and planet.**

**No matter where they are planted, trees in a city are part of our essential public infrastructure.** They cool off neighborhoods, suck up stormwater that would otherwise pollute the Sound, clean the air, and generally make it possible for us all to live in this place.

A city with no trees is a city where residents are even more vulnerable to heat stroke, asthma, and poor mental health, a city with no birds or wildlife. The City of Tacoma should regulate trees on private property because regardless of who “owns” them, we literally can’t live without them.

On top of that, the City already regulates private property in the form of construction permits that make sure our built environment is safe. If we can require a permit for building a deck in the interest of public health and safety, we can definitely require people to leave their healthy mature trees in the ground. Home in Tacoma Phase 2 will finally place a real value on the public benefits of many “private” trees. The biggest healthy trees will be illegal to cut down, and smaller ones will be removable with permission, for a price. This is progress that benefits everyone.

Thank you for  
considering!

Heather Carawan

TAcoma, WA

Get [Outlook for Android](#)

**From:** Elizabeth <elizabethcycles@gmail.com>  
**Sent:** Friday, September 20, 2024 5:00 PM  
**To:** City Clerk's Office  
**Subject:** Home in Tacoma Zoning and Standards package

Dear City Council,

Please do not pass the Home in Tacoma zoning changes. Instead, manage the zoning changes already made by House Bill 1110.

I am asking you to work with what the state requires to help address our housing shortage concerns. I am requesting that you do not implement even greater changes to our neighborhoods and communities. We all need time to adapt to change and taking a more moderate approach helps everyone to access the effect of the changes.

We recently moved here to retire in what we hoped would be our last home purchase. We love our neighborhood and we made a huge investment of our retirement income in order to live out our lives in the home and neighborhood of our dreams. I am afraid that making sweeping changes will change our neighborhood and allow greater density in our community while driving us out to find the space we thought we were buying. Please help us have a place here too.

Thank you for your time and consideration,

Elizabeth Salvo Heusel  
George Heusel  
964 S Fernside Drive  
Tacoma, WA 98465

**From:** Torrez, Alyssa  
**Sent:** Friday, September 20, 2024 4:47 PM  
**To:** City Clerk's Office  
**Subject:** FW: Home in Tacoma - Russell Rodgers 7018 S Alaska St Tacoma, WA also 1713 S 72nd St Tacoma WA -  
**Attachments:** City of Tacoma - U3- C 1 C 2 Zoning 08-22-2024.dot

Please see attached comment for the Public Hearing.

Alyssa

---

**From:** Russ Rodgers <russell.rodgers55@gmail.com>  
**Sent:** Thursday, August 22, 2024 12:59 PM  
**To:** Torrez, Alyssa <ATorrez@cityoftacoma.org>  
**Cc:** 'Russ Rodgers' <russell.rodgers55@gmail.com>  
**Subject:** RE: Home in Tacoma - Russell Rodgers 7018 S Alaska St Tacoma, WA also 1713 S 72nd St Tacoma WA -

Alyssa, I have prepared the letter attached for the meeting that you referenced on September 24<sup>th</sup>. Please review and let me know if this is what is needed or if I need to revise.

Also, do I send this to you or do I send to somewhere else.

Please advise.

Russ Rodgers

Please see attached.

## Counsel members and Staff

I am writing today as the Zoning in Tacoma is about to change and It appears that the area on the NW Corner of Alaska and 72<sup>nd</sup> Street has been overlooked. Most of the properties in this area are adjacent to and abut to Tacoma Place Shopping center. Because of their proximity to Tacoma Place these properties should already be Zoned Commercial but have retained the zoning of R2. It was understood that these parcels would be included in the re-zone related to the "Home in Tacoma" project, however, in the most recent version of the Home In Tacoma map it appears that these properties were actually rezoned to a less intensive R1 zone. I have spoken to staff several times about this and while all agree that it should be at least U3 zoning that change has never made it into the most recent maps. This general area was not included in the Home in Tacoma rezone area from its inception and should have been or it should have been re-zoned to commercial.

At a minimum this area should be zoned U3 and included in the Home In Tacoma zoning. If not then it should be zoned C1 or C2. To be consistent with the surrounding properties such as Tacoma Place Shopping Center, Starbucks, The Chiropractor across the street, the Gas station across the street etc..

I own two properties in the affected area **7018 S Alaska St Tacoma, WA and 1713 S 72nd St Tacoma WA -**

Thank you for your consideration to this



Russell Rodgers  
214-609-4413



2152 South Vineyard Suite 116 | Mesa, AZ 85210

phone: 480.610.2400 | fax: 480.610.2407

## Council members and Staff

I am writing today as the Zoning in Tacoma is about to change and It appears that the area on the NW Corner of Alaska and 72<sup>nd</sup> Street has been overlooked. Most of the properties in this area are adjacent to and abut to Tacoma Place Shopping center. Because of their proximity to Tacoma Place these properties should already be Zoned Commercial but have retained the zoning of R2 throughout the years. Based on conversation with staff and it was understood that these parcels would be included in the re-zone related to the "Home in Tacoma" project, however, in the most recent version of the Home In Tacoma map it appears that these properties were actually rezoned to a less intensive R1 zone. I have spoken to staff several times about this and while all agree that it should be at least U3 zoning that change has never made it into the most recent maps. This general area was not included in the Home in Tacoma rezone area from its inception but should have been or it should have been re-zoned to commercial.

At a minimum this area should be zoned U3 and included in the Home In Tacoma zoning. If not then it should be zoned C1 or C2. To be consistent with the surrounding properties such as Tacoma Place Shopping Center, Starbucks, The Chiropractor across the street, the Gas station across the street etc..

I own two properties in the affected area **7018 S Alaska St Tacoma, WA and 1713 S 72nd St Tacoma WA** and would like to see these properties be at least U3 or C1-C2 zoning.

Thank you for your consideration to this

Sincerely,

Russell Rodgers  
214-609-4413

**From:** Tyler Shillito <tyler@smithalling.com>  
**Sent:** Friday, September 20, 2024 4:41 PM  
**To:** City Clerk's Office  
**Subject:** September 23, 2024 City Council Meeting - HIT Comment

Please accept this email as my comment on the proposed Home in Tacoma (HIT) rezone.

I live on South Fernside Drive and my home is directly across the street from property which would be rezoned. I would ask that the city council not rezone the properties west of Jackson avenue for the following reasons:

1. The properties west of Jackson avenue are all subject to a residential covenant which prevents the construction of structures other than "one detached single family dwelling". The building heights are not to exceed two stories. The proposed rezone would run contrary to this covenant and very clearly would force the neighboring owners to sue to enforce this right. By passing the rezone as proposed the city would be creating disputes where none now exist. Allowing lots to be divided also will create a dispute under the covenant as it would be prohibited.
2. There are no sidewalks in the neighborhood west of Jackson avenue except on the north side of 6<sup>th</sup> avenue. If increased density occurs there is no safe way for additional people to get to Geiger Elementary or the 6<sup>th</sup> avenue business district. Jackson Ave. is already very busy and the traffic is extremely fast. My guess is that most cars traveling on Jackson are going well over 40 mph. Without sidewalks or a marked crosswalk (let alone crossing lights) it is extremely dangerous to cross Jackson or even walk along it. Putting higher density residential structures in West of Jackson will not address the dangerous road conditions. So while in theory "walking distance" is short between the area west of Jackson and Geiger, it is not in practical terms because to get "there" you have to go a significant distance to get to a safe crossing.
3. Every neighbor I have talked with in the neighborhood is opposed to the planned rezone west of Jackson. If the people living in the neighborhood do not want the rezone please do not force it on them.
4. Parking. There will not be enough on many of the streets since they are very narrow. If the rezone happens please make sure that any development has onsite parking, not parking which will flood our neighborhood with cars.
5. The standards in the rezone are designed to promote walking, biking and transit by locating denser housing within walking distance of schools, parks and transit. The problem with this proposal is none of that is truly accomplished in practical terms with this rezone First, there is one bus line on 6<sup>th</sup>, which granted is within walking distance but basically will only take you to the TCC transit center (about a mile away), where one can wait and get a transfer. Second, there is one park within walking distance (war memorial park) but it is really not a normal park since it has no playground, sports facilities or play field. It is a nice park and all, but families with children won't use it like a normal park. Plus it is right next to a very busy freeway on ramp. So the idea that people will live in dense housing and have an outlet at a nearby park is not the reality. Finally there are no large "employment centers" near the rezone here either, other than jobs at the businesses along 6<sup>th</sup>. It would make far more sense to have a rezone closer to the heavy commercial or industrial areas of the City. As for biking – there is no safe way to ride up 6<sup>th</sup> from West of Jackson unless you are on the sidewalk on the north side of the road. So unless 6<sup>th</sup> is revised to include a bike lane I don't see how the biking element of the standards is going to be met. Especially considering none of the arterials in the area have bike lanes. Nor even sidewalks (and shoulders) to ride on. While promoting walking, biking and transit is a great idea, in real world terms it will not happen if you allow denser housing west of Jackson.
6. Topography. The area west of Jackson is a hillside and any large structure (for instance a multifamily building) would loom even larger over the lower lots. Further I am not sure how the rezone would affect the already existing city mandated height limitation West of Jackson which I and many of my neighbors want maintained. The views of many homes would be severely impacted if the height limitation were changed. As I read the proposal the height limit would change to 35 feet, which is very tall and undoubtedly block views.
7. Trees. The area west of Jackson already has a strong tree and vegetation canopy. The rezone would significantly reduce the tree and vegetation cover.

Please do not change the zoning west of Jackson. The people who live there don't want it changed, it doesn't make practical/physical sense and at the end of it all a zoning change will end up causing lawsuits.

Sincerely,  
Tyler Shillito

**From:** Vice Chair <vicechairwenc@we-tacoma.org>  
**Sent:** Saturday, September 21, 2024 6:42 PM  
**To:** Cynthia Bertozzi Turco  
**Cc:** City Clerk's Office; Daniels, Kiara; Diaz, Olgy; Walker, Kristina; Hines, John; Dennis Munsterman  
**Subject:** Re: WENC's Comments for Home in Tacoma Public Hearing

I vote yes.

On Fri, Sep 20, 2024 at 3:36 PM Cynthia Bertozzi Turco <[cbturco@we-tacoma.org](mailto:cbturco@we-tacoma.org)> wrote:

As the full elected Board of the West End Neighborhood Council, we urge you to reject the Home In Tacoma Phase 2 proposal in favor of a less extreme plan.

Amended Ordinance 28793 had no mandate. It passed due to a patchwork of compromises and promises. As we review the Phase 2 plan, we realize that compromises were thrown out and promises were broken. The proposed plan is overreaching. It exceeds the intent of Amended Ordinance 28793 and the state legislative mandate. Please vote for a moderate plan.

#### Our Recommendations

1. Lower the density levels by merging UR-2 into UR-1. UR-2 uses a misguided view of access to justify mid-level density in our neighborhoods, something that was soundly rejected in Phase 1.
2. Limit density in a merged UR-1 and UR-2 to no more than the state-mandated 4 housing units plus 2 affordable bonus units.
3. Limit density in UR-3 to the standards that you have labeled as UR-2.
4. Retain deep and wide setbacks and 25' height restrictions that were used for residential zoning before Home in Tacoma.
5. Require design standards in terms of scale and architectural style to ensure new buildings are compatible with neighborhood patterns.
6. Strengthen tree canopy requirements to ensure that developers don't opt out.
7. Require at least one designated parking space per housing unit.
8. Ban shipping containers for housing and residential storage.
9. Require developers to pay all impact fees.

#### Points to Consider

1. The state legislature's zoning plan for the entire state means that a reduced burden has been placed on Tacoma.
2. The Growth Management Act requires periodic review and provides for modification if the burden becomes too heavy for urban areas.

3. The city's population figures seem inflated, given long-term trends and recent demographic shifts.
4. The populations of Portland and Minneapolis have dropped (despite upzoning) due to quality-of-life issues.

Respectfully,

Cynthia Bertozzi Turco, Chair  
Janice Fikse, Secretary  
Dennis Munsterman, Treasurer

**From:** patricia fetterly <pfetterly\_57@hotmail.com>  
**Sent:** Saturday, September 21, 2024 4:31 PM  
**To:** City Clerk's Office  
**Subject:** Home in Tacoma Landscape Code  
**Attachments:** TUFF - Final Letter to City Council on HiT Landscape Code September 2024.docx



**September 20, 2024**

Mayor Woodards and Members of the City Council:

**The ordinance implementing Home in Tacoma (HiT) must include protection for Tacoma's tree canopy.** HiT is Tacoma's most comprehensive zoning change in more than 60 years. It will bring new housing choices to many parts of the City. Unless tree protections are included, devastation of tree's urban canopy, already the lowest of any Puget Sound city, will continue at an accelerated rate. Any discussion of the need for balance between development and tree protection must first start by acknowledging that for more than 100 years, Tacoma failed to protect its urban forest. Implementation of HiT with the tree protections recommended by the Planning Commission is essential if the City is to avoid continued loss of its urban forest.

**Trees are critical infrastructure.** Unlike grey infrastructure (pipes, roads, bridges buildings etc.), green infrastructure (trees) actually increases in value and capacity over time. Trees are not just objects of beauty. Trees, in particular mature trees, are essential infrastructure to address environmental and public health disparities created by past decisions and to mitigate the disparities that are coming with climate change. Mature trees are critical pieces of public infrastructure to ensure our communities are healthy and livable. Tacoma recognized this in 2019 when the Council adopted its Urban Forestry Plan. Because trees are critical infrastructure essential for public health, space must be made for trees across the City, including residential zones. If not, people will essentially be packed into neighborhoods that are developed-out as much as possible with hardly any trees – and no mature trees. Those neighborhoods will be hotter, less healthy, less walkable and, overall, less livable.

**Mature trees must be retained.** It takes a tree 20 to 30 years of growth to begin providing essential environmental benefits. Planting is for the future while our standing trees are for now and the future. Typical development is to clear the lot, build new structures then plant new trees around it, if at all, which often die and are never replaced. The landscaping code proposed by the Planning Commission includes protection of large trees. Protection of large trees combined with the planting of new trees is essential. The code proposed by the Planning Commission includes amendments with variance language making it harder and more expensive to remove existing trees. As an addition to the variance provisions of the code proposed by the Planning Commission which makes the Director of Planning the decision maker as concerns whether to grant variances, the city forestry staff must be included in this decision process in order to provide a voice for mature trees. Since mature trees are critical public infrastructure, we shouldn't let people remove public infrastructure without approval and without paying for it. Other cities recognize this and still have denser development. Tacoma can do it too.

**Fee in lieu isn't the only answer when a conflict exists between development and tree retention.** The burden of establishing that tree removal is essential to allow development to proceed must be high. Fee in lieu must not be used to allow larger developers to pay their way out of retaining mature trees or planting trees on site. Allowing replacement trees to be planted on land the City controls, namely our already forested gulches and open spaces that either don't need more trees or don't have spaces for more trees, is not a solution. As the City Forester has often pointed out, Tacoma does not have sufficient open space to accommodate planting fee in lieu trees. At a minimum the recommendation of the Planning Commission that fee in lieu trees be planted on site or within one quarter mile of the new development must be included.



**New trees can't replace canopy loss due to development if they do not survive.** Developers who profit from projects that require tree removal must be required to ensure that newly planted trees because of the need to remove mature trees on the development site survive. It is not enough to assume that new homeowners will care for the newly planted trees to allow their survival and growth to maturity. This is especially true for UR 3 developments which will likely not be owner occupied. Developers must be required to follow proper planting techniques and maintenance of newly planted replacement trees for three years to ensure their survival. This should preferably be accomplished by bonding requirements. The City must have the authority to issue fines for continuous tree deaths due to negligence. This will require regular inspections by city forestry staff and input from forestry staff concerning the reasons for the failure of newly planted trees to survive and advice on the species of replacement trees most likely to survive.

**Fees collected in lieu must be used for urban forestry purposes.** The maintenance and replacement costs incurred by city staff discussed above should be paid for by fees collected in lieu of requiring trees which must be removed to allow planned development to proceed. Fees collected in lieu must be held in a dedicated fund, outside of the City's general fund. This fund should only be accessed for urban forestry purposes as approved by forestry staff. Annual audits must take place to ensure compliance to ensure that funds collected are actually used for urban forestry purposes.

**Minimum tree canopy of 20 percent tree coverage must be included in all zones.** Like developments in UR 1 and UR2 zones the code must provide minimum tree canopy coverage for developments in UR 3 and not allow developers to count street trees in determining whether minimum tree coverage requirements have been met. All residents of the City should receive the benefits that trees provide whether or not they own their own homes. If tree city-wide equity is to be achieved the benefits of urban trees must also be extended to city residents including those who are renters who are more likely to live in denser areas of the City. Minimum on-site tree coverage must be required in all housing units, whether classified as UR1, UR2, or UR3.

**Tacoma's urban forest is in an emergency.** The landscaping protections in HiT must take effect immediately upon passage rather than the effective date of the HiT ordinance. Even after passage of protection for right of way trees in 2023, removal of Tacoma's street trees continued at an alarming rate because permits to cut were applied for and approved prior to the effective date of the new ordinance. The same thing will happen when a HiT landscaping code is passed if the landscape code does not take effect immediately upon passage and property owners take advantage of the gap between passage and effective date to clear lots of trees to make them more attractive for developers. This must not be allowed to happen. The landscaping code contained in the HiT ordinance must take effect immediately upon passage as an emergency.

**Trees vs housing is a false dichotomy.** Before the right balance between development and the urban tree canopy can be achieved, it must be acknowledged that trees are starting from a deficit. Tacoma can reach its housing goals along with stronger tree protections. Housing and urban forestry both promote the quality of life in our city. Passage of the landscaping code is an opportunity to achieve both.

Sincerely,

**TACOMA URBAN FOREST FRIENDS (TUFF)**

*A Community-based Advocacy Group*

**From:** Jane Evancho <jane\_evancho@wamail.net>  
**Sent:** Saturday, September 21, 2024 9:14 AM  
**To:** City Clerk's Office  
**Cc:** Mike and Nancy Fleming; J Quilici; Judy Manza; elizabethoneal@windermere.com; Tom Riordan; THOMAS CLINE; Constance Hoag; jimschock@hotmail.com; Karen Kelly; Tom Rickey; Bev Grant; jane\_evancho  
**Subject:** Public Comments Home in Tacoma  
**Attachments:** Letter to City Council re HIT Phase 2.pdf

Please see attached.

--

This email has been checked for viruses by AVG antivirus software.

[https://urldefense.com/v3/\\_\\_http://www.avg.com\\_\\_;!!CRCbkf1f!Se9MwIqgYf5hx9k5N4p0W6jla5p083cs\\_oKkIP-UfLI6M4VOhG1tBh5qya2vv3gfejTeMfrUpiFTqZfwtqvKC58hrWUVUQ\\$](https://urldefense.com/v3/__http://www.avg.com__;!!CRCbkf1f!Se9MwIqgYf5hx9k5N4p0W6jla5p083cs_oKkIP-UfLI6M4VOhG1tBh5qya2vv3gfejTeMfrUpiFTqZfwtqvKC58hrWUVUQ$)



# WEST SLOPE NEIGHBORHOOD COALITION

P.O. Box 64321 Tacoma, WA 98464-0321

## **OFFICERS**

### **Chair**

Jane Evancho  
jane\_evancho@wamail.net

### **Vice Chair**

Mike Fleming  
mrfleming@netzero.net

### **Recording Secretary**

Judi Quilici  
jqquil@harboret.com

### **Treasurer**

Judy Manza  
pjmanza@harboret.com

### **Membership Chair**

Elizabeth O'Neal  
elizabethoneal@windermere.com

### **Communications Chair & Representative At Large**

Tom Riordan  
tom@thecircleltd.com

## **AREA REPRESENTATIVES**

### **Narrowmoor 1 (6<sup>th</sup> Ave to S 12<sup>th</sup> St)**

Tom Cline  
clinetg@comcast.net

### **Narrowmoor 2 (S 12th to Suspension)**

Constance Hoag  
constance.e.hoag@gmail.com

### **Narrowmoor 3 (Suspension to S 19th)**

Jim Schock  
jimschock@hotmail.com

### **Narrowmoor 4 (SR16 to 6th Ave) & Citizen Emergency Response Team**

Karen Kelly  
kmmkelly916@gmail.com

### **Mt. Narrowmoor (East of Jackson)**

Tom Rickey  
tom@tomrickey.com

### **Sunset & Titlow (West of S. Mt. View)**

Beverly Grant  
beverly@bevgrantlaw.com

September 20, 2024

To: Tacoma City Council

Subject: Home In Tacoma Zoning & Standards package

Thank you for this comment opportunity. Following are our key points that we request you consider:

1. Implement House Bill 1110 - The City of Tacoma proposal is overreaching. We urge the City Council to manage the substantial changes required by House Bill (HB) 1110 and not pass additional zoning increases. HB1110 allows low-scale buildings such as duplex and triplexes in single family neighborhoods. Home in Tacoma goes far beyond this, categorizing neighborhoods into three different zones that allow 8 to 12 units on many lots and even 3, 4 and 5 story apartment buildings in certain neighborhoods.

The State's low-scale zoning could provide needed housing while also preserving the livability of our neighborhoods. Staff resources should be focused on successfully implementing the State-mandated zoning changes of HB1110.

2. Proposed Setbacks - The Existing Conditions Report describes the post-war setbacks as 25 feet, with street parking, instead of an alley. The City's zoning proposal states "Front setbacks reduced from 20 feet to 15 feet in UR-1 & 2, and 10 feet in UR-3. This will be hugely jarring and destroy the nature of the neighborhood if implemented. We suggest as an alternative that the setback should be an average of the two adjacent lots. This would be stipulated even with the housing bonus 1 and 2.

3. Revise UR-2 Proposed Zoning District west of Geiger Montessori School to UR-1. This refinement aligns with the City Council's policy decision during HIT Phase 1 to lower zoning for the Vista Drive area.

Not all UR-2 designated areas on the city map are compatible with their surroundings. Parcels west of Jackson Ave. are now designated as UR-2. We understand this is because of perceived proximity to the Geiger Montessori School. While houses are within the 1/8th mile designated range "as the crow flies", in practicality, they are well outside the referenced walking distance if a student were to cross Jackson in a designated crosswalk at 6th Ave. or S. 12th St.

In addition, the Vista Drive area has been identified as geologically sensitive, with a ground slope of 15-25 percent, as noted in the 2020 Staff Analysis Report, West Slope Neighborhood View Sensitive Overlay District, Exhibit "B". This area is adjacent to the "Gulch" (7704 and 7702 6<sup>th</sup> Avenue) which has been identified by staff as a green erosion buffer that needs to retain a tree canopy. Tree removal has already occurred in

the development of homes in the Gulch. These adjacent parcels, geologically sensitive, cannot support up to 6 living units (UR-2 zone).

4. Public Notification - Our comments on Phase 2 scope of work in April, 2022, asked for "a public opportunity for comment before any discretionary land use decision is implemented, allowing for an appeal opportunity before the courts become involved." Staff responded in an email on 2/29/2024 that for the most part, residential development under the proposal would NOT include public notification. Development of missing middle housing would be allowed "by right." Bonus 1 would be an administrative review, not requiring notice. Bonus 2, however, (the fully affordable project bonus) would require a Conditional Use Permit and would have notification.

We respectfully ask that this be reconsidered. We believe some form of public notification needs to occur. Can a public notice be posted on the property 10-15 days prior to permit issuance?

5. Municipal Code change (pg 42) - Chapter 13.06.010 General Provisions revision to B. Zoning code administration-General purposes states "More specifically, the zoning code is intended to:

a. Provide a guide for the physical development of the City in order to:

(1) Preserve the character and quality of residential neighborhoods (strike), Add: Support the City's housing growth strategy:

We have consistently asked that the neighborhood character be retained as a goal throughout the Home In Tacoma process. **This statement should be retained.** Strike the new language "Support the City's housing strategy", which applies zoning according to a few general criteria and does not account for diverse neighborhoods.

6. Affordable Housing - The Home In Tacoma project was initially proposed to include more affordable housing, preferably with home ownership opportunities. We believe this has now become a project for more housing units, at market rates. We hope you will give consideration to recent actions in California with SB 4. This law enacted in 2023 allows non-profit colleges and faith-based institutions to build up to 30 units/acre in major cities, regardless of local zoning rules and also fast tracks their approval so long as 100% of the units are affordable housing with below market-rate rents. We encourage an expedited and simplified housing permitting for churches and other charitable organizations.

Respectfully,

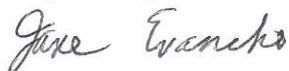

Jane Evancho

Chair, West Slope Neighborhood Coalition

**From:** Peter Bennett <peterbennett237@gmail.com>  
**Sent:** Sunday, September 22, 2024 11:10 PM  
**To:** City Clerk's Office  
**Cc:** <board@nenc.org>; Exec Committee  
**Subject:** Home in Tacoma 2 - September 24 Public Hearing - NENC Comments  
**Attachments:** NENC Comments on Home in Tacoma 09-24-2024 Public Hearing.pdf

Please find attached written comments submitted by the North End Neighborhood Council.

Thank you

Peter Bennett  
NENC Chair

Peter Bennett  
[peter@peterbennett.org](mailto:peter@peterbennett.org)  
253-223-1526

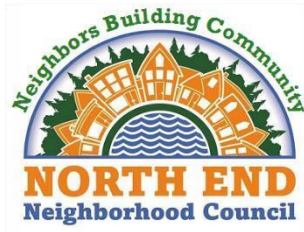

North End Neighborhood Council

2522 N Proctor St, Box 418

Tacoma, WA 98406-5338

[www.NENC.org](http://www.NENC.org) [www.facebook.com/NENCTacoma](https://www.facebook.com/NENCTacoma)

[www.twitter.com/NENCTacoma](https://www.twitter.com/NENCTacoma) [info@nenc.org](mailto:info@nenc.org)

September 22, 2024

The Mayor and City Council  
City of Tacoma  
733 Market St.  
Room 11  
Tacoma, WA 98402

Dear Mayor Woodards and City Council Members,

The North End Neighborhood Council (NENC) is pleased that the Home in Tacoma proposal is now under review by the Tacoma Council. Regrettably, the Planning Commission recommendation fails to address the issues that were raised in the comments and suggestions submitted in response to the Home in Tacoma 2 proposal. This failure has necessarily given the City Council the responsibility to address, and answer, the concerns of the NENC and many other organizations and individuals.

In our specific case, despite our organization's active participation in the development of the proposal through both Phase 1 and Phase 2, there was no outreach in response to our comment letter (NENC letter of March 1, 2024 attached). The NENC requests that the Council ask Planning and Development Services to provide an analysis of the public comments received through the outreach process. If that analysis shows a preponderance of comments are not represented in the current proposal, then it is important that there is a dialogue to understand and answer those concerns to show that this process (and the City Council) is willing to consider the viewpoints of all the residents of Tacoma.

In addition to the issues raised in our earlier comments letter, we would like to add two additional issues:

### **Trees and Amenity Space**

The NENC is appreciative that the Home in Tacoma process has acknowledged the importance of tree canopy especially the value of the retention of existing mature trees. The development and implantation of a robust "Landscaping Code" will be a necessary step in the City of Tacoma meeting its 30% tree canopy goal.

### **Impact Fees**

The NENC is encouraged to learn that the City Council is acknowledging that Impact Fees have a role to play in the development (and redevelopment) of Tacoma's housing stock. In addition to

the fact that large parts of Tacoma's utilities may not be sufficient to accommodate additional density there is a "fairness" issue if the utility impacts of new development are not borne by the new beneficiaries.

Finally, we suggest that the Council again review the Minority Report (document attached) that was submitted by three members of the Planning Commission in response the initial Home in Tacoma proposal. Does the Home in Tacoma 2 proposal address the issues raised in that letter? This is a document that appears to be as relevant to Home in Tacoma 2 as to the first proposal, and perhaps, the lack of submission of a further Minority Report is more reflective of the composition of the Planning Commission than any changes in the proposal itself. The following quote from that document represents a significant concern to the community that our organization represents.

**..... we will not see affordable development occur as a result of HIT. We will see more development in Tacoma, but it will be of the type that we have seen recently in the Proctor District - higher end developments with expensive rents. Little will be done to improve affordability. In the process, some historical buildings will necessarily be removed, the character of our neighborhoods forever changed, and we will still be faced with an affordability crisis.**

We look forward to further engagement to ensure that Home in Tacoma is a strategy that meets the City's needs by seeking win-win solutions where no neighborhood or community feels its specific issues have been overlooked or ignored.

Sincerely

*Peter D. Bennett*

Peter Bennett  
NENC Board Chair

CC: Community Council of Tacoma

Attachments:

NENC letter of March 1, 2024  
Planning Commission Minority Report of Mar 26, 2021

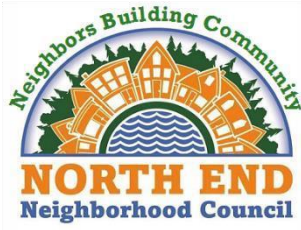

North End Neighborhood Council  
2522 N Proctor St, Box 418  
Tacoma, WA 98406-5338  
[www.NENC.org](http://www.NENC.org) [www.facebook.com/NENCTacoma](https://www.facebook.com/NENCTacoma)  
[www.twitter.com/NENCTacoma](https://www.twitter.com/NENCTacoma) [info@nenc.org](mailto:info@nenc.org)

March 1, 2024  
Tacoma Planning Commission

747 Market St.,  
Room 345  
Tacoma, WA 98402

Dear Commissioners,

The North End Neighborhood Council (NENC) has been an active participant in the development of the Home in Tacoma proposal including hosting multiple well attended presentations by Senior Planner Elliott Barnett. We share the concern about the city's current and anticipated challenges and look forward to working with city staff and leadership to prepare for a more diverse, equitable, inclusive, and sustainable city. We were encouraged by some of the changes made in response to feedback to the original Home in Tacoma outline; one good example being the landscaping code intended to protect and expand the tree canopy which is necessary to meet the city's goal of 30% citywide coverage. However, the extent of the changes since the outreach during the Home in Tacoma Phase 1 is so significant that the NENC feels unable to support the current proposal.

#### Current Residential Pattern of the City of Tacoma

In reviewing the abundance of information provided as part of the city's outreach efforts we reviewed the Portland State University "Residential Pattern Areas" study of Tacoma from 2015. As this study provided the impetus for the Home in Tacoma program, we are concerned that the process may have moved away from the findings and recommendations contained in that study which clearly identifies different residential patterns within the city and cautions that "one size does not fit all". We are suggesting that, rather than adopt all the final Home in Tacoma recommendations citywide, parts of the program should be "tested" in certain smaller defined areas as pilot projects to both confirm that desired results are achieved and identify any unintended impacts.

#### Impact of new statewide standards because of HB 1110

We are aware and acknowledge that the passage of housing density legislation in Olympia has changed the planning criteria that the City of Tacoma must comply with. However, we are concerned that, rather than adjust the housing density requirement upward to meet these new requirements, the Home in Tacoma 2 proposal uses the statewide standard as a new base and increases the density up to double those required by the state. The community feedback to Home in Tacoma Phase 1 showed that there was a concern about the increased density being proposed. The new state legislation provided the City of Tacoma with a blueprint to build



citywide support for the Home in Tacoma concept. However, by proposing standards beyond those envisaged in Home in Tacoma Phase 1, and in many cases more than state mandates, the city is increasing opposition to your proposal and building further division. This is especially true in well-established neighborhoods. There is no need to increase density as your research has already concluded that unmet and potential housing demand can be accommodated under the Home in Tacoma Phase 1 standards.

### Impacts from Proposed Bonus Plan

The proposed bonuses will allow elimination and/or reductions in community and individual assets (tree canopy, open space, parking, etc.) in exchange for increased affordability and building retention. We believe that the affordability goal is better achieved through other avenues, such as the tax deferral program for mixed use centers, and building retention is a core value that should not be subject to negotiation. The UR3 new height bonus of 4 to 5 story apartments is a significant concern on several issues including the loss of sunlight into homes, yards, and privacy of adjacent 1-2 story homes.

### Neighborhood Equity

Of significant concern are Home-Owner Associations and View Sensitive Districts who are effectively exempt from the bonus zoning changes (8 to 12 units) proposed, either through Covenants, Conditions and Restrictions or because of height protection limits up to 20 or 25 feet. The new proposals will exacerbate the issue of "Neighborhood Equity" between areas that are considered attractive for redevelopment (no height protections or CCR's) and those that are considered unattractive (or unprofitable).

### Burden of Infrastructure Improvements Costs

We are concerned that the Home in Tacoma process has failed to acknowledge that the costs of infrastructure improvements in Tacoma are placed on the existing residents. Every other jurisdiction requires builders to pay impact fees and the combination of the infrastructure costs associated with increased density and an expected growth in the Multifamily Property Tax Exemption (MFTE) Program will inevitably increase the tax burden on existing residents.

### Ongoing Community Involvement

Our final major concern is the lack of Home in Tacoma Phase 2 to address and encourage continued community involvement in local housing issues. Because Home in Tacoma Phase 2 is a prescriptive proposal it is likely that neighborhood involvement in planning issues will be less rather than more. Therefore, the more radical the proposed changes are the greater the perception that decision making is centralized and remote ignoring any neighborhood concerns and thoughts.

### Summary

In summary, our recommendation in response to the Home in Tacoma Phase 2 is:

- Phase Home in Tacoma implementation by use of Pilot Projects prior to citywide implementation.
- Use the new state housing density regulations as the maximum density for the Urban Residential designations of 6 units in UR 1 and UR2.
- Remove UR3 new height bonus of 4 to 5 story apartments.
- Address the issue of Neighborhood Equity throughout the whole city including those with Home-Owner Associations and View Sensitive Districts by staying within the state mandate of a six unit maximum for UR1 and UR2.
- Address the affordability issue for existing residents by implementing an impact fee for new construction.
- Consider how local involvement can be incorporated into Neighborhood Planning decision making.

Thank you for your consideration of these suggestions and we look forward to further engagement to ensure that Home in Tacoma is a strategy that meets the City's needs by seeking win-win solutions where no neighborhood or community feels its specific issues have been overlooked or ignored.

Sincerely

*Peter D. Bennett*

Peter Bennett  
NENC Board Chair

CC: NENC Board Members  
Elliott Barnett  
Mayor & City Council Members  
Community Council of Tacoma

May 26, 2021

The Honorable Mayor and City Council

City of Tacoma

747 Market Street, Suite 1200 Tacoma, WA 98402

**RE: Home In Tacoma Project - Minority Report**

Honorable Mayor Woodards and Members of the City Council,

We, Commissioners Mcinnis, Edmonds and Givens, want to offer this Minority Report to provide an explanation for not fully supporting the *Home in Tacoma* Project. As is often the case in a complex issue like this, those that vote against it do so for differing reasons. In order to properly explain the reasons for the three 'nay' votes, I have categorized the reasons below and identified the dissenting commissioners that are in agreement. Suffice it to say, however, that the haste with which Home In Tacoma has been compiled and moved forward is a concern shared by all of

us and the underlying reason for all of our itemized concerns below. This matter is much too important for us to get wrong.

Commissioners Mcinnis and Edmonds believe that the Home in Tacoma (HIT) plan will not respond to the affordable home crisis that we are experiencing in Tacoma. While HIT creates an environment in which additional housing can be created, the units that will be created are going to do very little for affordable housing. Both Vice Chair Mcinnis and Commissioner Edmonds have considerable experience in the real estate and development market. We understand the process that developers go through to evaluate a project. Projects that could be built for affordability typically require reduced development costs and are often built in areas with reduced real estate costs.

Those are not the types of developments that will be created by HIT because HIT does nothing to encourage developers to seek lower cost real estate nor does it provide any relief from "soft" development costs (permits, etc.). There are still significant development costs to overcome in these "market-rate" projects, and HIT does nothing to respond to that. The projects that will be created as a result of HIT will be those with sufficient revenue to allow payback in the timeline required by lenders.

For that reason, we will not see affordable development occur as a result of HIT. We will see more development in Tacoma, but it will be of the type that we have seen recently in the Proctor District - higher end developments with expensive rents. Little will be done to improve affordability. In the process, some historical buildings will necessarily be removed, the character of our neighborhoods forever changed, and we will still be faced with an affordability crisis.

We have an opportunity and responsibility to find real ways to provide affordable housing in Tacoma. Doing so well requires a much more detailed approach than a blanket policy affecting the entire City. It requires:

1. Finding ways to reduce development costs with reductions in permitting fees and timelines
2. Reviewing each neighborhood for opportunities to provide incentives for developers to pursue redevelopment of specific parcels
3. A policy with real thresholds and requirements about how affordable development can actually be realized, such as height bonuses, tax abatements, and permit cost and timeline relief

While we understand the desire to put something forward quickly, the Home In Tacoma policy misses the mark. We need to take additional time to put together a real policy that truly addresses affordable housing in Tacoma instead of putting forward a hastily compiled policy that will do nothing to address our current problem while at the same time erode the quality and character of Tacoma.

In summary, Vice-Chair Mcinnis and Commissioner Edmonds have concerns that the policies (i) will not produce affordable housing, (ii) will encourage a different type of development that will change

neighborhood character (iii) will fail to address affordability, (iv) will reduce single-family housing supply, (v) and will cause building-scale conflicts in existing neighborhoods.

**Mapping Concerns** - All three commissioners are concerned with the map agreed upon by the Commission. These concerns include:

- **Low-Scale Residential Housing Opportunities appear Sufficient to Respond to Housing Needs:** The proposed policy changes would allow for additional housing types in addition to single- family houses in the Low-Scale classification (e.g., duplexes, triplex, & cottage housing) - this increases our housing capacity/options in existing neighborhoods with less reliance on expanding the Mid-Scale Residential designation.
- **The Mid-Scale Residential expansions are not focused near designated Corridors/Centers** - we believe that future Mid-Scale Residential should be introduced at strategic locations as part of neighborhood planning activities over the next five years. Neighborhood-level refinements would allow for additional community engagement, target housing on underutilized properties, and focus new midscale residential near parks, schools, colleges, commercial nodes, and similar existing housing types.
- **Apartments are Introduced in Isolated Locations:** The proposed map introduces MidScale Residential at seemingly isolated locations across the city which are outside established nodes, transit corridors and neighborhood centers and/or near clusters of existing apartment/townhouse development (e.g., **N. 15<sup>th</sup>**, Norpoint Way NE, 49<sup>th</sup> Avenue NE, E. Roosevelt).
- **The Plan Creates Low-Scale Islands:** The proposed map amendments will create small islands of LowScale Residential that would be otherwise surrounded with Mid-Scale Residential (e.g., N. 24<sup>th</sup> & Warner Street, N. 11<sup>th</sup> & Alder, **N. 9<sup>th</sup>** & Union, S. 11<sup>th</sup> & Pine, S. 80<sup>th</sup> & Yakima) .
- **The Plan Creates Disproportionate Expansions in Certain Neighborhoods:** Due to irregular block configurations, the proposed map amendments would disproportionately expand Mid-Scale Residential into existing neighborhoods (e.g., south of the 5<sup>th</sup> Ave. Center, NW edge of Hilltop, E. 55<sup>th</sup> & McDacer).
- **The Plan Fails to Recognize Existing Apartment Clusters:** The proposed Mid-Scale Residential designations are not applied to existing apartment/townhouse communities near Corridors/Centers, which perpetuates nonconforming situations and limits expansions (e.g., west/east sides of U. of Puget Sound, N 5<sup>th</sup> & K, N. Grant & Division, S. 9<sup>th</sup> & Sheridan).

We believe the project's expedited timeline prevented the Planning Commission from fully discussing all issues attending this important issue and from arriving at a project that will respond to the needs of the majority of the residents of Tacoma.

We hope this provides clarity on why we were unable to reach full consensus. Like our fellow commissioners, we acknowledge that Tacoma is facing an unprecedented housing crisis and our land use/regulatory framework should provide more diverse housing options while recognizing existing neighborhood character.



**Jeff McInnis, Vice-Chair**



**Carolyn Edmonds, Council District 2**

Tacoma Planning Commission

Tacoma Planning Commission

A handwritten signature in black ink that reads "Ryan Givens". The signature is written in a cursive, flowing style.

**Ryan Givens, Architecture, Historic Preservation, and/or Urban Design**

Tacoma Planning Commission

**From:** patricia fetterly <pfetterly\_57@hotmail.com>  
**Sent:** Sunday, September 22, 2024 10:59 PM  
**To:** City Clerk's Office  
**Subject:** Home in Tacoma Landscaping Code  
**Attachments:** Letter to City Council re HiT Landscaping Code.docx

September 22, 2024

Mayor Woodards and Members of the Tacoma City Council:

My name is Patricia Fetterly. My husband Lloyd and I have been residents of Tacoma's District 2 for more than 35 years and raised our family in this city. Home in Tacoma presents the City with a unique opportunity to improve the quality of life in Tacoma in two ways: by increasing the supply of housing in the City and by protecting and expanding our urban tree canopy to a healthy level. Both increased housing density and protecting and expanding our urban tree canopy are policy goals previously established by the City Council. **They are not contradictory or mutually exclusive goals. To the contrary, they are policy goals which complement each other because both promote the quality of life in our City.**

When the City Council adopted the Urban Forest Management Plan in 2019 and set a goal of increasing Tacoma's tree canopy from 19 percent to 30 percent it recognized that urban trees are essential infrastructure necessary to protect public health and ensure livable communities. Trees are not simply objects of beauty which are "nice to have" provided they do not interfere with maximum development. Tacoma presently has the lowest tree canopy of any city in Puget Sound. Our urban forest continues to be cut at an alarming rate, making it extremely unlikely if not impossible to reach 30 percent by 2030, just a little over five years away.

Implementation of Home in Tacoma, Tacoma's most important zoning change in more than 60 years, without including the Landscape Code recommended by the Planning Commission will result in the continued decimation of the City's urban forest and will lower the quality of life in our City. All residents of the City - whether they live in single family homes, mid rise housing or larger multifamily complexes - deserve the health benefits that trees provide. The proposed Landscaping Code works to balance the needs for housing with the need to protect mature trees (which are most efficient at removing and storing carbon as well as providing other benefits) and encourages the planting of new trees. Both are needed for a healthy, livable city which will attract new residents and living wage jobs. Other cities have achieved greater housing density along with tree protection. There is absolutely no reason that Tacoma can't also. Development will still come. It will not be stopped by the inclusion of protections for our urban forest consistent which incorporate existing City policies to protect our urban forest.

I urge you to include the tree protections contained in the Landscaping Code with the implementation of Home in Tacoma

Patricia Fetterly

**From:** Kim K <kyminator@gmail.com>  
**Sent:** Sunday, September 22, 2024 9:28 PM  
**To:** City Clerk's Office  
**Subject:** Home in Tacoma

We fully support plans to increase housing throughout Tacoma.

Kim and Vince Kueter  
802 S Shirley St  
98465



**From:** Tim Olsen <Tacoma@luth.org>  
**Sent:** Sunday, September 22, 2024 5:55 PM  
**To:** City Clerk's Office  
**Subject:** HIT public hearing comments

Dear Mayor and City Council –

Trees are essential public infrastructure, providing much-needed services like shade, pavement cooling, storm water mitigation, physical and mental health benefits, and numerous others. It is now well-known that tree canopy is a social justice issue which shows the lingering damage caused by past prejudices such as red-lining.

The City Council has been right to set goals for increasing our tree canopy, which is now the worst among the cities of the Puget Sound area. But I fear that the Home in Tacoma legislation poses yet another threat to those goals.

The big trees do all the work. It is not possible for any canopy-increase plan to succeed without first preserving our mature trees. The trees we plant today will someday be able to provide the services we need, but not until they are large enough to do so, and that will take decades.

We can increase our housing density without sacrificing our vitally-needed canopy, but the provisions of Home In Tacoma do far too little to encourage and incentivize the preservation and planting of trees. Please do not let developers remove our already-feeble tree canopy while promising to plant some tiny trees later and elsewhere. The math just does not work, and even if it did, one suspects that those promises would somehow be evaded.

I hope that the proposed Landscaping Code will be approved and take effect as soon as possible. I hope that the City will strongly increase funding for the Urban Forestry department. I hope that the City will move decisively to plant new trees and take responsibility for their watering and maintenance. Yes, I'm just full of hope.

I support the good work of citizen groups such as Tacoma Tree Foundation (TTF) and Tacoma Urban Forest Friends (TUFF). But it is the City's job to do what citizen groups cannot: Protect and build our essential infrastructure. I'm talking about our trees. Our trees, and our future.

Tim Olsen  
Fern Hill neighborhood, Tacoma

**From:** Deb Olsen <Deb@luth.org>  
**Sent:** Sunday, September 22, 2024 5:00 PM  
**To:** City Clerk's Office  
**Subject:** Comment on Home in Tacoma for Sept 24 public hearing

Dear Mayor and City Council –

I am concerned about the effects Home in Tacoma in relation to our tree canopy, which is currently the lowest of any city in the Puget Sound region. While there is a need to increase housing to the level required by state law, we can at the same time protect mature trees that are vital to the health, welfare and quality of life of all who live and work here.

I hope the Council will consider these vital points:

- We are just starting to take steps to protect and increase our urban forest after decades of neglect. We are playing catchup and can't afford to lose more tree canopy, especially with the effects of climate change.
- The work that mature trees do to provide shade, cooling and water retention in neighborhoods cannot be replaced by planting new trees without the decades needed for their growth. We must protect mature trees as well as plant new ones if we are ever going to reach the city's stated goal of 30% tree canopy. The goal of increasing tree canopy has been put forward by the city since 2008. We need an emergency plan that prioritizes conservation and planting.
- Protecting and increasing tree canopy can be compatible with increased housing as long as we focus our building in existing high-density areas (like downtown) and don't overbuild in neighborhoods where we need to maintain mature trees.
- Trees need to be valued as critical infrastructure for the job they do for us: shade, cooling, walkable neighborhoods, storm water retention, and more. They are not nuisances that can be easily replaced once destroyed. The city can demand that developers preserve trees whenever possible and not just pay a fee in lieu for removal. It takes 20-30 years or more for an average tree to start to provide the service of mature trees, and we need their benefits now.
- The proposed Landscaping Code should be approved and take effect immediately before more trees are lost.
- Tree planting also needs to be a high priority for the city, with sufficient funding for the Urban Forestry department to help us reach our tree canopy goals. The city needs to adopt and fund a comprehensive and massive tree-planting program.

I support the Tacoma Urban Forest Friends (aka TUFF) and the letter we have sent to the City Council on the Home in Tacoma Landscape Code. I hope you will read carefully its well-researched and thoughtful recommendations and take the actions that are necessary to make Tacoma more livable, equitable and green.

Sincerely,  
Debra Olsen  
Fern Hill neighborhood, Tacoma

**From:** Seth Gebauer <seth.gebauer03@gmail.com>  
**Sent:** Sunday, September 22, 2024 4:26 PM  
**To:** City Clerk's Office  
**Subject:** Home in Tacoma Phase 2 Written Comment

Hello,

My name is Seth Gebauer, and I live in the Hilltop neighborhood. I am writing to urge the city council to adopt the full zoning and landscaping recommendations of the Planning Commission for the implementation of phase two of Home in Tacoma. Our region and our city is facing a housing affordability crisis, which is fueling displacement, which I feel particularly in the hilltop neighborhood. My friends and neighbors are having to make the terrible decision to leave behind their friends, relatives, communities, and support systems to find more affordable housing elsewhere. Allowing denser, affordable housing is a much-needed solution in the fight against displacement across Tacoma. The recommendations of the Planning Commission also align with the City's Climate Action Plan, by reducing sprawl, ensuring development is located in areas with the infrastructure that can support it, and preventing further inequitable environmental consequences of development that has become a pattern in Tacoma and elsewhere.

The landscaping recommendations of the Planning Commission are also crucial to implement, as they can preserve our existing tree canopy alongside the encouragement of further housing development. The best time to plant a tree was ten years ago - even if the City accelerates urban tree planting programs, current mature trees are critical to protect when developing new housing. Trees are critical infrastructure - they provide clean air, reduce the impacts of urban heat waves on our most vulnerable neighbors, help mitigate stormwater runoff into our watershed, and promote neighborhood cohesiveness.

Passing Home in Tacoma Phase 2 is crucial to addressing the housing crisis in Tacoma, and building a more livable, green future for our city.

Thank you,  
- Seth Gebauer, City Council District 3

**From:** JEREMY JACKSON <jeremy.jackson5@icloud.com>  
**Sent:** Sunday, September 22, 2024 4:14 PM  
**To:** City Clerk's Office  
**Subject:** Written Comment - Home in Tacoma Zoning & Standards Package

Jeremy Jackson 514 S Sheridan Ave Tacoma, WA 98405 253.514.9927 23 SEP 2024

Tacoma City Council

Tacoma Municipal Building

747 Market Street

Tacoma, WA 98402

Dear Honorable Members of the Tacoma City Council,

I am writing to express my strong support for the new zoning plans that aim to encourage higher density and create more walkable, livable, and sustainable communities in Tacoma. As a concerned citizen and a long-time resident of this great city, I am excited about the potential of these plans to shape the future of our community.

I recently had the opportunity to read Jeff Speck's book "Walkable City," which provides a compelling case for why walkability is essential for creating thriving, equitable, and environmentally friendly cities. Speck's principles resonate deeply with me, and I believe that incorporating them into our zoning plans will have a transformative impact on Tacoma.

The proposed zoning plans align with many of the principles outlined in "Walkable City," including:

1. Mixed-use development: By allowing a mix of residential, commercial, and recreational uses in the same area, we can create vibrant, dynamic neighborhoods that reduce the need for lengthy commutes and promote local economic activity.
2. Density: Increasing density in strategic areas will help to support local businesses, reduce sprawl, and promote more efficient use of resources.

3. Walkability: Designing streets and public spaces that prioritize pedestrian safety and accessibility will make our city more livable, promote physical activity, and foster a sense of community.

4. Connectivity: Creating a network of connected streets, bike lanes, and pedestrian paths will improve mobility, reduce congestion, and enhance overall quality of life.

By embracing these principles, Tacoma can become a model for sustainable, equitable, and resilient urban development. I urge you to move forward with the proposed zoning plans and to continue to engage with the community throughout the implementation process.

Some specific recommendations I would like to make include:

- Prioritizing pedestrian-friendly design in all new

development projects

- Encouraging mixed-use development in areas with high transit accessibility
  
- Implementing traffic calming measures to reduce speeds and improve safety
  
- Providing incentives for developers to incorporate affordable housing and community spaces into their projects

I believe that these measures will help to create a more livable, sustainable, and equitable Tacoma for all residents. I look forward to seeing the positive impact of these zoning plans and to continuing to work with the City Council to build a brighter future for our community.

Thank you for your dedication to making Tacoma a great place to live, work, and thrive.

Sincerely,

Jeremy Jackson



**From:** LeAnne Laux-Bachand <leanne.lauxbachand@gmail.com>  
**Sent:** Sunday, September 22, 2024 1:35 PM  
**To:** City Clerk's Office  
**Subject:** Home in Tacoma feedback

To Whom it May Concern:

I'm writing to voice my continued support for the HIT plan. I believe I live in the proposed Urban Residential 3 zone (on 21st across the street from the Cushman substation), and I'm supportive of the plan for more high-density housing.

Thank you,  
LeAnne

**From:** drmkinnear@gmail.com  
**Sent:** Sunday, September 22, 2024 1:12 PM  
**To:** City Clerk's Office  
**Subject:** Tacoma City Council September 24th HIT Rezoning meeting

Deputy Mayor Hines and Tacoma City Council,

Please vote **against** changing the zoning from UR-1 to UR-2 on Vista Drive, Tacoma. I live at 640 Vista Drive, which has a recommendation to change from UR-1 to R-2 in HIT Phase 2.

Please keep Vista Drive as UR-1, which the city council directed for HIT Phase 1.

I appreciate your consideration,

Michael Kinnear  
640 Vista Drive  
Tacoma, WA 98465  
Dist. 1

**From:** Danielle Harrington <danielleharrington2@hotmail.com>  
**Sent:** Sunday, September 22, 2024 1:11 PM  
**To:** City Clerk's Office  
**Subject:** comments on Home in Tacoma Zoning

To COT City Council,

We own a home in the Proctor District that is zoned to be UR-2 with the new HIT Zoning plan. We are writing to express support for this plan as it considers ways to make housing affordable, maintain and grow tree coverage to help mitigate climate change and allows for urban growth while help minimizing development in other green spaces.

A few considerations:

- We very much value assuring Tacoma reaches its 30% tree canopy goal. With the bonuses provided for people who provide affordable housing on their property, there is an allowance of reduced tree coverage. We want to make sure that we don't end up with high density urban areas that do not have quality tree coverage. We highly value the COT street tree program and encourage you to continue to fund trees in these potential higher density urban spaces to make sure ALL people have access to shade and the benefits of green spaces.
- With the potential reduction in yard/amenity space as our neighborhoods grow denser, our parks are all the more essential. We are proud of the work Metro Parks does in our community and encourage ongoing collaboration and work to foster these green spaces for all Tacoma residents.
- This may be in the plan, and we may have not seen it. With the reduction of parking spaces having a more robust and accessible transportation system is essential with Pierce and Metro Transit. We are slowly heading in the right direction, but we need to move faster to make sure that folks can actually rely on transportation that runs frequently enough to get to work, school, and errands.
- There should be a requirement or some sort of subsidy for new housing to have level 2 chargers for EV vehicles. These vehicles will be part of our work to reduce CO2 emissions, and in more dense areas with limited parking, folks will need ways to easily charge their batteries.

Thank you for all your hard work and creating this plan and all the thinking to make sure our city is a vibrant, affordable and vibrant place to live for generations to come.

Sincerely,  
Danielle Harrington and Stephanie Leisle  
4416 N. 27<sup>th</sup> Street  
Tacoma 98407

•

**From:** Kathleen Brooker <kbrooker1@gmail.com>  
**Sent:** Sunday, September 22, 2024 12:33 PM  
**To:** City Clerk's Office  
**Subject:** HiT Public Comment for 9/23/2024 City Council PH

Greetings. As registered Tacoma voters we are providing written comment to the City Council for the 9/24/24 public hearing on Home in Tacoma.

Many residents objected to the increased density proposed in the first variation of HiT. Concerns ranged from scale to tree canopy to parking. However, the Planning Commission largely ignored these comments and instead recommended to extended the area and increased the allowable density. Upscale gated and view neighborhoods are excluded from this plan.

We urge Council to reject this aggressive proposal for Tacoma's residential neighborhoods. It would make more sense to work with the guidelines the State has laid out (and which Seattle is adopting). Let's see how this works before going into overdrive. We urge you to reconsider this extreme path and put forward a reasonable and incremental plan for density.

Thank you.

Sincerely,  
Kathleen Brooker and Timothy McDonald

417 North M Street  
Tacoma 98403

**From:** Dawn Nanfito <dawn.nanfito@gmail.com>  
**Sent:** Sunday, September 22, 2024 10:40 AM  
**To:** City Clerk's Office  
**Subject:** Home in Tacoma Phase 2

I don't know who at all will read this, but I will write anyway.

I have read with fascination the requests I have received recently to attend the upcoming City Council meeting where Home in Tacoma Phase 2 will be addressed. Again. I have carefully distanced myself from this whole topic since 2022 when I had nightmares and explored moving to Oregon. I avoid the emotional angst on purpose so I can get on with my life. You don't care about Tacoma and its neighborhoods or the real problems that this city has.

Home in Tacoma is not going to solve the problems you think it will solve. I doubt you have investigated, but studies are inconclusive (<https://www.urban.org/research/publication/land-use-reforms-and-housing-costs>, here's a shorter summary: <https://www.governing.com/community/zoning-changes-small-impact-on-housing-supply-affordability-study>). This is not a whack job group with an agenda, BTW). And why is this necessary now that the State has passed legislation?

I wish this city would focus on its actual problems. I don't hold out hope though.

Dawn Nanfito

**From:** KIMBERLEY HITCHCOCK <kkhitchcock@yahoo.com>  
**Sent:** Sunday, September 22, 2024 8:31 AM  
**To:** City Clerk's Office  
**Subject:** Home in Tacoma

Do not pass the Home in Tacoma zoning changes. We are not Seattle and we have no desire to become Seattle.

[Yahoo Mail: Search, Organize, Conquer](#)

**From:** Marshall McClintock <marshalm@q.com>  
**Sent:** Monday, September 23, 2024 7:40 AM  
**To:** City Clerk's Office  
**Subject:** HiT2 public hearing comment

Mayor Woodards and City Council,

I urge you to reject the current radical HiT2 proposal.

The current proposal goes far beyond what the state currently requires, to which it should be scaled back. Even Planning Div. Mgr Brian Boudet has stated repeatedly that "Mid-scale" (UR-2, UR-3) is not needed to meet Tacoma's 2050 housing needs. The proposal is inequitable since View Sensitive Districts, Tacoma's wealthiest areas with that largest parcels, have height limits of 20 ft and 25ft. Either reduce all height limits in residential zones to 25 ft or increase VSD heights to 35 ft. Finally the current proposal simply turns Tacoma's residential neighborhoods over to developers for unregulated development. It allows and even encourages the grossly inappropriate infill now allowed in MUCs and which we were told in HiT1 would never be allowed in R-1, R-2, R-3 and HMR-SRD.

Regards,

Marshall McClintock  
701 N. J Street

**From:** Elliott Barnett <elliottbarnett1@gmail.com>  
**Sent:** Monday, September 23, 2024 8:53 AM  
**To:** City Clerk's Office  
**Cc:** Planning  
**Subject:** Support for HIT package

Dear City Council and City staff,

I am writing with a quick message of support and gratitude for your work as you consider final changes to and adoption of the Home In Tacoma package. Since my family moved away from Tacoma this June, we have been traveling in the US and abroad. This has given me lots of time to think about how other cities manage growth and change, and reflect on the work that Tacoma is now doing. I have seen lots of great examples of middle housing, affordability, urban forestry, walkability, adaptive reuse of buildings, sustainability—the goals of the HIT Project are priorities for many cities now. That said, I've also visited cities that are not there yet in terms of these issues (stuck in a suburban development pattern), and in contrast I have seen instances where cities have seen dense development, but not managed to get the public benefits that should come with it (such as accessibility, connectivity, affordability and investment in public spaces).

This time of reflection has confirmed for me that Tacoma is on a very positive path. You are creating regulations that will allow housing development and, I believe, will work for the development community, as they need to in order to get housing built. At the same time, you are ensuring that development brings with it essential public benefits like trees, affordability and pedestrian connectivity. Though I believe this is a great package, it's also a big change and undoubtedly there will be a need for refinements identified through implementation—work for you, and my former colleagues, in the years ahead. That said, I see a package that is a win win for all of us, as it should be.

Thank you for taking on the real challenges facing our city, and our planet. You should also be commended for the priority you place on fostering collaborative dialogue and transparent, responsive governance—that may be the most important action of all, and should not be taken for granted.

Working on the HIT Project was the high point of my planning career. I am proud to have been a part of it and am cheering for you from afar. Thanks for taking care of my city while I am away!

Warm Regards,  
Elliott Barnett



**From:** Robin Lubow <lubow6@gmail.com>  
**Sent:** Monday, September 23, 2024 9:52 AM  
**To:** City Clerk's Office  
**Subject:** Zoning Changes

We strenuously object to the proposed HIT2 changes in zoning! Let's keep historic historic!

Robin & Carl Lubow  
810 N J St Tacoma 98403  
Sent from my iPhone

**From:** Courtney Davis <c.davis622@gmail.com>  
**Sent:** Monday, September 23, 2024 10:06 AM  
**To:** Woodards, Victoria; Hines, John; Daniels, Kiara; Walker, Kristina; Scott, Jamika; Bushnell, Joe; Diaz, Olgly; Rumbaugh, Sarah; Sadalge, Sandesh; City Clerk's Office  
**Subject:** Comment Regarding Landscaping Code as a Part of HiT

Hello Mayor and City Councilmembers,

I am writing to you all today in support of the landscaping code (with the amendments proposed by the Planning Commission). City council has promised a 30% tree canopy by 2030 and the mechanisms within the landscaping code will finally allow a path to achieving that goal. Through **tree preservation** and **tree planting requirements**, we will finally be able to increase our canopy from the embarrassingly low amount that it stands at today. Both preservation and planting are an important element to code and I'd ask that you not alter the recommendations the Planning Commission has proposed. They are experts in their fields and have worked with the city planning department and the consultants to ensure that this code will work within our city. There have been case studies done in collaboration with TPAG to show there is room for trees on sites and there's countless amounts of research to show that a 30% tree canopy leads to a healthier and more thriving community (including statements from the TPCHD!).

As it stands, the number and placement of trees within our city is leading to greater inequity and health disparities. You won't hear developers or TPAG mention this specific point; you'll only hear them talk about how this new code "can't be accomplished" and will significantly inhibit development. This is not true and this false trees vs housing dichotomy needs to be squashed. The reality is that the requirements set forth by the landscaping code will allow for much more **affordable** housing and will ask above market rate developers to be creative in their designs. This accomplishes what we want within this city and allows for Tacoma to be a thriving and healthy place to live and also allows for there to be affordable housing options for those who already reside here. Above market rate housing does not accomplish this goal, and allows for further gentrification.

I'll leave you with two perfect examples of why the landscaping code must move forward. Examples like these must be prevented in the future:

-Construction next to Charlotte's Blueberry park on D Street: 127 above market rate townhomes going in a currently 100% forested area of Tacoma that already has low tree canopy. These houses are not going to benefit the community and no one in that area will be able to afford the prices of these above market rate homes. So, a significant amount of tree canopy is being lost and the community is not benefitting.

-Madison Complex Redevelopment: Above market rate housing being put in one of the only green spaces in the Tacoma Mall Neighborhood. An affordable housing proposal by Metroparks and Tacoma Housing Authority was declined, so this area is losing its only green space and the housing being built is not benefiting the residents of that neighborhood.

The bonus structure within the Landscaping Code as it stands will incentivize affordable housing. And it will ensure that the city is liveable and a healthy place for residents to thrive.

Please do not allow the above market rate development community's voices to be heard over the true needs of this city. Please **pass the landscaping code as-is** as soon as possible to ensure a healthier future for your residents!

Thank you for your time,  
Courtney Davis

**From:** William Owen <willmichowen@gmail.com>  
**Sent:** Monday, September 23, 2024 10:28 AM  
**To:** City Clerk's Office  
**Subject:** Support for Higher Zoning alternative for Home in Tacoma

Good morning,

I want to write in to express support for the higher zoning alternative on the Home in Tacoma rezoning plan. Tacoma is a wonderful place, and I'd like to see it shared with more people.

I believe a lot of the issues with west coast cities becoming unaffordable and plagued by homelessness have to do with a failure to build enough homes in these areas. A higher housing target like the one in the higher zoning alternative would help avoid this pitfall.

Thank you for your time and consideration.

Warm regards,  
William Owen

**From:** Vickie Norlin <[vickieandsteve@yahoo.com](mailto:vickieandsteve@yahoo.com)>  
**Sent:** Monday, September 23, 2024 10:42 AM  
**To:** City Clerk's Office  
**Subject:** Please do NOT rezone our neighborhood!

We live in the West Slope neighborhood of Tacoma. We love that this area is full of diverse individuals, living in lower height, single family homes. We are strongly against amending the residential zoning restrictions to include multi-family and multi-story homes. The impact on parking, traffic, trees and vegetation, as well as the views of Puget Sound would be devastating. Please do not rezone our neighborhood!

Respectfully,  
[vickieandsteve@yahoo.com](mailto:vickieandsteve@yahoo.com)

**From:** Benjamin <benjatoon@gmail.com>  
**Sent:** Monday, September 23, 2024 11:53 AM  
**To:** City Clerk's Office  
**Subject:** Home In Tacoma

Please pass the zoning and landscaping standards recommended by the planning commission.

Benjamin Gehlke-Montes  
Sent from my iPhone

**From:** Cady Chintis <cadychintis@gmail.com>  
**Sent:** Monday, September 23, 2024 12:12 PM  
**To:** City Clerk's Office; John Wolters  
**Subject:** Public Comment on Home in Tacoma Phase 2 City Council Public Hearing 9/22/24

Dear City of Tacoma Councilmembers,

As a resident and business owner in Tacoma for nearly a decade, I want to express my full support for expeditious adoption and enactment of Home in Tacoma per the planning commissions recommendations. In particular, I strongly support the commission's unanimous guidance on tying the Reduced Parking Area to expanded light rail service and frequent transit streets identified in the municipal code (Pacific Avenue, S 19th Street, and 6th Avenue).

Linking the development of housing and parking raises the cost of new housing. More critically though, it subsidizes and disguises the true cost of private car ownership and handcuffs the city's future development to unsustainable car-centric policies. It has been widely studied that adding lanes to roads increases traffic volume resulting in the same or worse congestion as before. Continuing to increase Tacoma's off-street parking supply means square footage that could otherwise be utilized for more or larger dwelling units and amenity space will instead be dedicated to storing vehicles. Meanwhile traffic volume and parking congestion throughout the city will increase because driving will be the default transportation choice for everyone that is able to afford it. And unfortunately for those who can't afford it or just prefer not to, alternative transportation options and car-sharing programs will remain limited or non-existent.

In order for Tacoma to meet its climate, equity, and traffic safety goals, we need residential density that supports compact, mixed-use neighborhoods with services, schools, jobs, recreation, and transit connections within walking and biking/scooting/skating distance. The ability to live in a place like this gives people the choice to live a more affordable car-free or car-light lifestyle using sustainable transportation for all or most of their trips. Enacting the Home in Tacoma policy with the expanded RPA as recommended by the planning commission is an essential step to maintaining and improving Tacoma's livability as the city grows.

Obviously, concurrent infrastructure improvements are needed to facilities like sidewalks, bike lanes, and bus stops. Street trees play an incredibly important role in creating comfortable and safe streets for all users. A dense deciduous street tree canopy provides summer shading over sidewalks, transit stops, bike lanes, and street parking while naturally slowing traffic. For this reason, I would encourage the council to consider flexibility or trade-offs to the proposed on-site tree credits in exchange for enhanced street tree planting (beyond the minimum street tree requirement). Developable lots on corners, for example, would be able to maximize buildable area within their property boundary while contributing an equivalent amount of tree canopy that has a greater public benefit in the right-of-way. Following the enactment of the current HIT package, future planning efforts focused on infrastructure and impact fees should prioritize the undergrounding of power lines along designated pedestrian/cycling/transit corridors so that these "complete streets" can benefit from full size trees rather than being limited to the significantly smaller power-line friendly species.

Sincerely,

Cady Chintis  
1522 6th Ave #1  
Tacoma, WA 98405

**From:** Cathy Carruthers <cathycarruthers@gmail.com>  
**Sent:** Monday, September 23, 2024 12:26 PM  
**To:** Home In Tacoma; City Clerk's Office  
**Subject:** Home ownership for single parents

Dear City Council Members,

Thank you for launching the home in Tacoma effort.

I know that the city can't solve every problem. However, I have two items that are an ask.

1. Make it easy for people to offer a space for a tiny home on wheels. People should be allowed to live in these year around rather than for 90 days.
  - a. The median wage for single parents in Tacoma is \$21 per hour. (ZIP Recruiter) The needs of single parents are not well covered now. As one friend said "I'd like to have a place of my own. Something that can't be taken away from me if I make the payments."
  - b. Many home and land owners don't have enough cash to build a tiny home and rent it out to low income people like these single parents. But it's relatively cheap to create a place for a tiny home on wheels to be hooked up.
  - c. Home ownership is the dominant form of wealth accumulation. Until the price of housing comes down, it will not be possible for single parents to accumulate wealth in this way. Owning a tiny home will allow single parents to begin this process.
  - d. There's an existing supply of tiny homes on wheels available for resale. A policy shift could quickly expand housing supply within Tacoma. It could create spaces while people get their finances together for stick built permanent tiny homes.
  - e. This could be done on an experimental basis if there's a concern about stability in housing supply, including the tax base, housing codes, or compliance as tiny homes move in or out. This would follow the testing model served by the initial ADU build out of the last few years. You could set the requirements to preserve safety, such as egress windows for storage lofts or DHPs to replace propane or wood stoves.
2. It would be nice if the new infill structures didn't shade existing solar systems.



**From:** emily@norpoint.com  
**Sent:** Monday, September 23, 2024 12:38 PM  
**To:** City Clerk's Office  
**Subject:** Home in Tacoma - written comment

I am against changing zoning in residential areas to allow up to 4 units to be built.

1. **Value of Historic Neighborhoods** – The Council should place more value on the history and character of our historic neighborhoods. No one wants Tacoma to look like the neighborhoods in Ballard or many other neighborhoods in Seattle. This proposed zone change will drastically change the character of our neighborhoods. Once you rip out the historical homes, that historical quality is gone for good.
2. **Limiting accessibility for first time home buyers** - This will make it very difficult for first time homebuyers to purchase an affordable starter home. Developers will snatch up anything remotely affordable to build multi-plexes, and likely list the “homes” for just as much if not more than the original home.
3. **Build up high density areas** - We still have many areas intended for high-density (just look at downtown, Pearl Street, 6<sup>th</sup> Ave, and other neighborhoods). Why not incentivize building more housing in those areas? Changing the zoning in our residential neighborhoods seems like an absolute last resort.

--

Emily Westman  
Operations Manager  
Norpoint Communities  
Email: [emily@norpoint.com](mailto:emily@norpoint.com)  
Office: (253) 759-2287

**From:** Roger Johnson <rajohnson@wamail.net>  
**Sent:** Monday, September 23, 2024 12:46 PM  
**To:** City Clerk's Office  
**Subject:** Home in Tacoma hearing

To the Tacoma City Council,

The efforts to change zoning to increase density is not a new idea. Amsterdam in the Netherlands is a prime example where it works. The reason it works is there is a superb web of public transportation that is city wide. Cars have been restricted in many areas because the zoning allows small shops for all services to survive and as a consequence cars are not need. The public transportation is inexpensive and frequent and city wide. Tacoma is not at all to the stage where public transportation is useful. Build the public transportation before a complete rezone.

Thank You,  
Roger Johnson

**From:** Tom Lowe <loweper@gmail.com>  
**Sent:** Monday, September 23, 2024 12:48 PM  
**To:** City Clerk's Office  
**Subject:** NO HIT!

Hello,

I live in the College Park Historic District on N. 10th and Junett Street. Washington State and the US Government recognize us as a historic district. I strongly oppose HIT because I believe House Bill 1110 is enough. The first portions of HIT were created and passed during a global pandemic. Public meetings were limited to ZOOM, and I believe this plan intends to create developer-friendly ordinances.

This city planning commission has proven over and over again that they cannot hold developers to design standards. There are multiple examples of new housing without regard for neighborhood impact, tree canopy compliance, and maintaining street appeal. Homes that once stood proud are now in shadow, squeezed between modern atrocities. HIT is far-reaching and will foster out-of-control development in our historic neighborhoods. Neighborhoods that, in many opinions, are the reason Tacoma is such an attraction.

HB 1110 will take more time, allowing for design standards, infrastructure upgrades, and a sane approach to the needs of this community.

Tom Lowe

**From:** THOMAS CLINE <clinetg@comcast.net>  
**Sent:** Monday, September 23, 2024 12:53 PM  
**To:** City Clerk's Office; Jane Evancho; mike & nancy fleming  
**Subject:** Abandon Home In Tacoma

Tacoma City Council

**The Home In Tacoma proposal is overreaching and unnecessary.**

State of Washington House Bill 1110 will provide needed housing while also preserving the livability of our neighborhoods. HB1110 allows low-scale buildings such as duplex and triplexes in single family neighborhoods. Home In Tacoma goes far beyond this and should be **abandoned**.

Tacoma's staff resources should be focused on successfully implementing the State-mandated zoning changes of HB1110.

Stop this unnecessary Zoning by the City of Tacoma.

Respectively  
Tom Cline  
7535 S Hegra Rd  
Tacoma, WA. 98465

**From:** Laura Svancarek <LauraS@downtownontheho.org>  
**Sent:** Monday, September 23, 2024 1:26 PM  
**To:** City Clerk's Office  
**Subject:** Home in Tacoma Phase 2 Comments  
**Attachments:** DOTG Home in Tacoma Phase 2 Sept.pdf

City Council Members,

Please see attached Downtown On the Go's comments regarding Home in Tacoma Phase 2, also copied below.

Thank you,

**Laura Svancarek (she/her)**

Downtown On the Go  
Interim Executive Director  
253-252-6638 Cell  
[www.downtownontheho.org](http://www.downtownontheho.org)  
[Facebook](#) | [Twitter](#) | [Instagram](#)

[Support our work!](#)

Register now for our annual fundraiser Move & Groove with DOTG, October 17th 6pm-8pm at West of the Waterway. [Tickets on sale now!](#)

Dear Council Members,

On behalf of the Downtown On the Go's Board of Directors and staff, I am writing to share our thoughts and suggestions around Home in Tacoma Phase 2

Downtown On the Go (DOTG) is the transportation advocate and resource for anyone whose life is in the greater Tacoma area. We work across sectors to make Tacoma a better place to walk, bike, and take transit.

### **DOTG supports the current Home in Tacoma package**

In February 2024, DOTG provided the Planning Commission with comments expressing our support of their proposed Home in Tacoma package. We are firmly supportive of density and believe that allowing missing middle housing types throughout the city is necessary if we are to achieve the dense, walkable, complete neighborhoods that Tacoma deserves. Our support includes the bonus density opportunities in the proposal.

We also support the Commission's recommendation of enhanced bicycle parking requirements. As Tacoma's bicycle network becomes more complete and ebikes become more accessible, we are seeing an increased interest in cycling. We often hear from residents that the lack of secure bicycle parking is a major barrier to their riding. This is especially a concern for those living in multifamily units without easy storage or in units accessed by stairs. Increasing bicycle parking requirements will undoubtedly increase cycling in those worried about storage or theft.

Overall, DOTG appreciates that the proposal consistently goes beyond the minimum requirements of House Bill 1110. The decisions we make now will influence how Tacoma grows for the next generation and directly impact our strategies on climate and mobility. This package gives Tacoma an opportunity to be a state-wide leader with bold policy and aggressive goals.

### **Parking Minimums**

DOTG has been vocally supportive of the expanded Reduced Parking Area (RPA) since its introduction in 2023. The expanded RPA more accurately reflects Tacoma's upcoming transit landscape by including future High Capacity Transit

(HCT) projects and acknowledging areas like 6th Avenue which houses Pierce Transit's current highest performing non-HCT route. We also support the proposed city-wide parking minimum reductions.

Tacoma must invest in housing and access above the storage of personal vehicles. Parking adds significant expense to projects, increasing the rental costs of finished units. Parking takes up space which could be used for additional units or green amenities such as trees. The expanded RPA and additional reductions of minimums offer flexibility, greater affordability, and a path towards a more multi-modal and equitable city.

We urge the Council to adopt the expanded RPA as recommended by the Planning Commission. This is progressive policy that is necessary to meet our climate, housing affordability, and road safety goals.

## **Investment and Implementation**

We appreciate that Home in Tacoma encourages density in already complete, walkable neighborhoods which will need less immediate investment to ensure safe mobility. At the same time, the City must prioritize safety improvements for density in less complete areas, especially along transit routes and arterials. If we are discouraging personal vehicle ownership, we must make it safe, convenient, and accessible for residents of all ages and abilities to get around without a car. It is not acceptable to focus affordable housing along dangerous arterials without a plan to immediately address the safety concerns of pedestrians, cyclists, and transit users. Providing secure bike parking will not encourage more cycling if the surrounding roadways lack safe cycling infrastructure. Leaving these issues unresolved is a significant equity concern.

Our infrastructure investments show who is valued in our community. People who utilize non-drive alone travel modes often do not feel valued as they face traffic violence, incomplete or damaged facilities, and exposure to the elements. We can address this through street redesigns that prioritize those walking, cycling, and using transit. Improved crossings, wide sidewalks, protected bike facilities, bus shelters, and street trees are great ways to improve safety, make our streets more welcoming, and calm vehicle traffic speeds.

To meet our Vision Zero and Climate Action Plan goals, Tacoma must invest in completing our active transportation networks. Our facilities must not only show current users the respect they deserve, but also be attractive enough to entice new users to change their behaviors. This simply will not happen without increasing our levels of investment.

## **Recommendations**

DOTG strongly recommends that the City work to identify new funding sources to allow for the necessary level of investment in active transportation and transit infrastructure. We cannot rely only on grant opportunities, which require match funds and significant staff time. DOTG recommends serious consideration of impact fees, Transportation Benefits Districts (TBD), and Vehicle License Fees (VLF) as avenues for dedicated active transportation funding near to new development. We cannot make the necessary progress without increasing investment, and we cannot increase investment without additional funding.

To address equity concerns along arterials, we ask that the City identify how infrastructure investments can be required concurrently with new development. We know where the most density will be allowed, where the least parking will be required, and where the current gaps in infrastructure are located. Utilizing the Equity Index, we ask that investment be prioritized in these areas now. There is no need to wait until we start to see the impacts of Home in Tacoma - we can and must adjust our investment and prioritization strategies now as part of this process.

We hope you will take our feedback into account so we can build the best Tacoma we can for generations to come.

Sincerely,



Laura Svancarek,  
Interim Executive Director





950 Pacific Ave, Suite 300 | Tacoma, WA 98402

9/23/24

Tacoma City Council  
747 Market Street,  
Tacoma WA 98402

RE: Home in Tacoma Phase 2

Dear Council Members,

On behalf of the Downtown On the Go's Board of Directors and staff, I am writing to share our thoughts and suggestions around Home in Tacoma Phase 2

Downtown On the Go (DOTG) is the transportation advocate and resource for anyone whose life is in the greater Tacoma area. We work across sectors to make Tacoma a better place to walk, bike, and take transit.

### **DOTG supports the current Home in Tacoma package**

In February 2024, DOTG provided the Planning Commission with comments expressing our support of their proposed Home in Tacoma package. We are firmly supportive of density and believe that allowing missing middle housing types throughout the city is necessary if we are to achieve the dense, walkable, complete neighborhoods that Tacoma deserves. Our support includes the bonus density opportunities in the proposal.

We also support the Commission's recommendation of enhanced bicycle parking requirements. As Tacoma's bicycle network becomes more complete and ebikes become more accessible, we are seeing an increased interest in cycling. We often hear from residents that the lack of secure bicycle parking is a major barrier to their riding. This is especially a concern for those living in multifamily units without easy storage or in units accessed by stairs. Increasing bicycle parking requirements will undoubtedly increase cycling in those worried about storage or theft.

Overall, DOTG appreciates that the proposal consistently goes beyond the minimum requirements of House Bill 1110. The decisions we make now will influence how Tacoma grows for the next generation and directly impact our strategies on climate and mobility. This package gives Tacoma an opportunity to be a state-wide leader with bold policy and aggressive goals.

### **Parking Minimums**



DOTG has been vocally supportive of the expanded Reduced Parking Area (RPA) since its introduction in 2023. The expanded RPA more accurately reflects Tacoma's upcoming transit landscape by including future High Capacity Transit (HCT) projects and acknowledging areas like 6th Avenue which houses Pierce Transit's current highest performing non-HCT route. We also support the proposed city-wide parking minimum reductions.

Tacoma must invest in housing and access above the storage of personal vehicles. Parking adds significant expense to projects, increasing the rental costs of finished units. Parking takes up space which could be used for additional units or green amenities such as trees. The expanded RPA and additional reductions of minimums offer flexibility, greater affordability, and a path towards a more multi-modal and equitable city.

We urge the Council to adopt the expanded RPA as recommended by the Planning Commission. This is progressive policy that is necessary to meet our climate, housing affordability, and road safety goals.

### **Investment and Implementation**

We appreciate that Home in Tacoma encourages density in already complete, walkable neighborhoods which will need less immediate investment to ensure safe mobility. At the same time, the City must prioritize safety improvements for density in less complete areas, especially along transit routes and arterials. If we are discouraging personal vehicle ownership, we must make it safe, convenient, and accessible for residents of all ages and abilities to get around without a car. It is not acceptable to focus affordable housing along dangerous arterials without a plan to immediately address the safety concerns of pedestrians, cyclists, and transit users. Providing secure bike parking will not encourage more cycling if the surrounding roadways lack safe cycling infrastructure. Leaving these issues unresolved is a significant equity concern.

Our infrastructure investments show who is valued in our community. People who utilize non-drive alone travel modes often do not feel valued as they face traffic violence, incomplete or damaged facilities, and exposure to the elements. We can address this through street redesigns that prioritize those walking, cycling, and using transit. Improved crossings, wide sidewalks, protected bike facilities, bus shelters, and street trees are great ways to improve safety, make our streets more welcoming, and calm vehicle traffic speeds.

To meet our Vision Zero and Climate Action Plan goals, Tacoma must invest in completing our active transportation networks. Our facilities must not only show current users the respect they deserve, but also be attractive enough to entice new users to change their behaviors. This simply will not happen without increasing our levels of investment.

### **Recommendations**

DOTG strongly recommends that the City work to identify new funding sources to allow for the necessary level of investment in active transportation and transit infrastructure. We cannot rely only on grant opportunities, which require match funds and significant staff time. DOTG recommends serious consideration of impact fees, Transportation Benefits Districts (TBD), and

Vehicle License Fees (VLF) as avenues for dedicated active transportation funding near to new development. We cannot make the necessary progress without increasing investment, and we cannot increase investment without additional funding.

To address equity concerns along arterials, we ask that the City identify how infrastructure investments can be required concurrently with new development. We know where the most density will be allowed, where the least parking will be required, and where the current gaps in infrastructure are located. Utilizing the Equity Index, we ask that investment be prioritized in these areas now. There is no need to wait until we start to see the impacts of Home in Tacoma - we can and must adjust our investment and prioritization strategies now as part of this process.

We hope you will take our feedback into account so we can build the best Tacoma we can for generations to come.

Sincerely,

A handwritten signature in cursive script that reads "Laura Svancarek".

Laura Svancarek,  
Interim Executive Director

**From:** Mary Menard <mary4882@gmail.com>  
**Sent:** Monday, September 23, 2024 1:28 PM  
**To:** City Clerk's Office  
**Subject:** Home in Tacoma project public comment - curb cuts for driveways

With the zoning changes, parking will be even more important, as well as scarce.  
Make sure you allow homeowners to create driveway access on the street adjacent to their lot.

We cannot accommodate increased density, like ADUs, without having private driveways to give us off street parking.

I inquired 7 years ago, and city staff told me a curb cut was not allowed - even though half of my neighbors already have curb cuts and front yard driveways (by variance or unlawfully). Due to this and other factors, there is insufficient street parking as it is already.

Thank you,  
Mary Menard, Eastside Tacoma homeowner  
[mary4882@gmail.com](mailto:mary4882@gmail.com)

**From:** Alex Bergman <a.r.bergman101@gmail.com>  
**Sent:** Monday, September 23, 2024 1:28 PM  
**To:** City Clerk's Office  
**Subject:** Home in Tacoma Public Comment - Bergman  
**Attachments:** HOME IN TACOMA PROPOSAL - BERGMAN COMMENTS (1).pdf

Hi!

Please find my comments on the home in tacoma phase 2 proposal.

Many of my initial comments were not addressed in the revised proposal, I am essentially resubmitting the original comments for consideration, especially the first one, **please label the sheets of the code with the applicable chapter and section for easy reference.**

Thank you!

AB

--

Alexander Bergman  
Architectural Drafting & Design  
A.R.Bergman Drafting LLC  
<https://www.arbergman.com/>

360-280-0528





## **A.R.BERGMAN DRAFTING LLC**

**Office & Mailing Address:**  
**1422 N Anderson St Tacoma WA 98406**  
**TACOMA, WA 98406**  
**360-280-0528**  
**a.r.bergman101@gmail.com**

To whom it may concern,

My name is Alex Bergman. I work for an architect and am owner and operator of a residential drafting and design company here in Tacoma. I do many residential permits with the City of Tacoma on a regular basis. I also live near the college park neighborhood and intend to be a lifelong Tacoma resident.

I know you probably have many letters to review so I will try to keep my comments somewhat brief:

If there is one thing I hope gets through, no matter what happens with the code, it is that in the new copy, please provide a reference under the page number to the code on the page.

Often in the code, it references other sections (in zoning, it may reference a development standard) and in other published code (IRC, ICC, etc.) the referenced code is listed on the page it is published on for reference. Ever since I started working with the code it has been hard to use because of this one small thing that could be easily fixed, and make it so much more accessible.

My other primary opinion here is that I think the proposed landscaping standards are far too complicated, even for me, and I review and understand codes for a living. Please don't misunderstand - I am completely in favor of promoting a more verdant and beautiful Tacoma. I agree with the goal of 30% canopy in the city too, and I

would not ask to reduce that at all. I just think the additional requirements are long and complicated to a point that is discouraging. It is my understanding that a landscape architect or certified professional will be needed for all levels of development, and I think that puts things further out of reach for the average homeowner who wants to participate in small-level development. I don't think an urban forestry manual needs to be adapted to accomplish the canopy goal. I realize that this will probably not change much since it has been very thought out and developed at this point, but I would ask that in addition to the regulations a type of fast track form be provided to make the tree standard easier to achieve.

This could also include a short list of 25-30 common trees to use, with growth rates and canopy values attached to a fillable spreadsheet form (think WSEC glazing schedule or heat sizing form) which will perform the canopy ratio calculation based on your lots s.f. value, tree canopy/growth rate value/etc.

I can't imagine this would take much time or resources to develop and it would make it so much easier to address tree canopy in development going forward.

I also think that since there is so much promotion of development, you should do away with floor area maximums for detached structures, or at least increase the thresholds. I think that setbacks and open/yard/amenity standards are enough of a limitation to prevent overcrowding on site. Keeping the code the way it is may limit the practicality of two-unit backyard buildings. I believe more flexibility will promote growth and quality of newly established housing, affordable or otherwise, since this is the kind of development that should be most attainable for the average homeowner. Height restrictions should be more relaxed too. The new code replaces the small neighborhood low density approach, which is what I think this section (detached footprint maximum thresholds) of the code tries to serve. I think more freedom here will promote growth.

There are sections of the proposed code, I believe, that limit establishing parking within front yards. I don't know the purpose of this but I think we should be able to establish parking there. Any opportunity to establish off street parking should be entertained in my opinion. I know a lot of these parking standards are to promote public

transportation, which I agree with in theory, but I believe that in reality most people will be driving cars anyway. Pierce Transit in particular is not set to expand or dramatically improve public transportation in the near future to a point that would match the desired growth rate of public transit users. For larger developments, I believe space for service vehicles, maintenance vehicles, and guest vehicles are not being considered enough. We also have cramped streets in many neighborhoods, with 4' landscape strips on either sidewalk edge, which are tremendous and make the city beautiful, but limit driveability when lined with parked cars. I fear the limitation of these parking requirements is going to create much more on-street parking, especially for larger developments who do not establish 1:1 parking to unit ratios. I realize part of making transit more desirable is to disincentivize drivers, but I think this will have an undesirable effect for everyone.

A few last thoughts - I think pedestrian paths to ADUs should be able to temporarily cross driveways too if delineated. I also think the Residential Target areas and tax incentives should just be city-wide.

And finally, I believe the public comment period should be extended. I think there should be more time for us to review and develop meaningful comments on these wide-sweeping changes that are being proposed.

I thank you for all your time and attention to my comments. No matter the outcome, I am excited to see what happens and believe more growth is good for Tacoma.

Thanks so much!

AB

**From:** mike elliott <mike\_elliott99@hotmail.com>  
**Sent:** Monday, September 23, 2024 1:44 PM  
**To:** City Clerk's Office  
**Cc:** mike elliott  
**Subject:** HIT comments

Hello Tacoma City Clerk,

I submitted comments on Home in Tacoma last week but did not receive a confirmation email. Were my comments received?

Thank you,  
Mike Elliott



**From:** purchasing <purchasing@me.com>  
**Sent:** Monday, September 23, 2024 1:45 PM  
**To:** City Clerk's Office  
**Subject:** MORE PARKING IS A MUST!

I have been saying this for well over a year to no avail. When we increase housing density, we increase parking density. It is unrealistic to believe humans will give up their cars. We must require more parking spaces on the lots being improved. If we don't, stakeholders will revolt.

I don't want to live in a neighborhood where I have to search for parking. I want to be able to park in front of my home to schlep things in and out. My neighborhood is already tight for parking at times and neighbors get into disputes. We don't have driveways or garages and are dependent in street parking Code changes can require builders to go up vs out and to include parking inside new structures and/or to provide more parking on the lot. Please reconsider.

If parking is reasonable, this plan has my full support.

Colleen Gray  
3818 S 9th St

**From:** Michael Foley <folm235@yahoo.com>  
**Sent:** Monday, September 23, 2024 1:46 PM  
**To:** City Clerk's Office  
**Subject:** Home in Tacoma Comments

TO: Tacoma City Council  
FROM: Michael Foley, Tacoma

I am writing today to oppose the proposed rezoning plan that has been put forward by the Planning Commission. While I see the merits of the low-scale option and would like to see that pursued, with some further detail on design guidelines, I do not think the mid-scale option is right for the historic neighborhoods surrounding the MUCs, and more importantly, I do not think the mid-scale option will address Tacoma's need for affordable housing options. Since the passage of HB 1110 by the State, I think Tacoma should amend zoning and permitting to harmonize with the new state requirements first. This will allow the construction of duplexes, triplexes and quadplexes everywhere. This will do more to accommodate the need to fill in the "missing middle" while still preserving the unique character of our historic neighborhoods.

I agree that Tacoma faces issues of affordability that will remain unless steps are taken. However, the mid-scale plan that is under consideration is very unlikely to be effective, given the incentives faced by the private-sector developers who are being relied upon. Under the mid-scale plan, the housing that will be built near the priciest areas in Tacoma will likely be priced at or above the current average rents and prices in that area. This is what happened within the Proctor MUC with both of the large apartment buildings that went up over the past decade. Modest-sized single-family homes were torn down and were replaced with high-rent apartments. While population density (and traffic) certainly increased, the affordability of the housing got much worse. This is exactly what will happen with the mid-scale apartments that will be allowed under the plan. Many buildings will go up, but these will not be priced at a level that will address the housing needs of present residents of Tacoma who can't find affordable housing near the MUCs.

Tacoma is not a "closed" housing market. Building more high-end apartments here will simply attract the in-migration of residents from even higher cost areas such as Seattle, rather than triggering a local reduction in rents and prices down the whole housing cost curve. Tacoma's current residents will not only see more congestion, they won't see any benefit in reduced housing costs. It would make more sense to slow this process down, evaluate the impact of HB 1110 and see how much new housing stock gets built and how affordable it is.

I urge the Council to pause the mid-scale option, institute the low-scale option consistent with the new State requirements and then evaluate its effect in five years.

Thanks for reviewing my comments,

Michael Foley

Tacoma, WA

Sent from my iPhone

**From:** Tom Baier <tomtuttle1963@yahoo.com>  
**Sent:** Monday, September 23, 2024 2:02 PM  
**To:** City Clerk's Office  
**Subject:** Home in Tacoma - OPPOSE

Dear Council Members,

I've been following these issues closely and I just can't support the approach in the current Home in Tacoma proposal. It does nothing for affordability, doesn't address the cost of needed infrastructure improvements, doesn't discourage demolition, doesn't address existing tree canopy deficits, and is unresponsive to other needs expressed by neighborhood councils. Let's implement HB 1110 FIRST and then see if we need to go farther. Thanks for your consideration.

Tom Baier  
2016 N 29th St

**From:** Scott N. <putascottinit@yahoo.com>  
**Sent:** Monday, September 23, 2024 2:04 PM  
**To:** City Clerk's Office  
**Subject:** HIT Public comment (opposed)

Hello City Clerk's Office and others,

I believe that the proposed HIT package may as well be called the Ugly-fication of Tacoma (UFT) package.

The density planning in recent years included encouraging wording that neighborhood-level inputs would be influential on new construction. However, I see that that is not actually occurring, as evidenced by the 16 and 21 unit monster buildings that have appeared in many single-family lots, next to single family homes.

These buildings do not AT ALL fit the character of the neighborhoods or the city, and they do not enhance the quality and character of our city, except to satisfy some metrics. We can do better. Greater density does not need to be at any and all costs. We do not have to accept character-destroying blights in order to achieve city goals. Setbacks and trees matter. Neighborhood character and pride matter too.

The HB 1110 bill that was passed last year is plenty. Let's focus on that and implement it with full oversight and neighborhood-level input where communities can reasonably influence the direction of their neighborhood.

Duplexes/Triplexes and even four or six unit developments can be built in many lots while still fostering community character and pride, AND achieving city goals. If the economics of developing multi-family projects favor 16 and 21 unit projects, then those larger unit projects need to be limited to very specific spaces, such as within UCX zones. UR1 to UR3 and URX should be limited to HB 1110 standards.

The large efforts by many city departments and people to increase density and affordability are very appreciated. But I believe they have gone off the rails and need to be reigned in. HIT should not continue. HB 1110 is enough.

Thank you.  
Scott Nelson  
McKinley Hill resident

**From:** Farmer, Lakecia  
**Sent:** Monday, September 23, 2024 2:15 PM  
**To:** City Clerk's Office  
**Cc:** Boudet, Brian; Caan, Christina; Lynett, Kristin; Pauli, Elizabeth; Smyth, Geoffrey; Torrez, Alyssa  
**Subject:** STC Home in Tacoma Phase II Letter for Public Comment  
**Attachments:** STC Home in Tacoma Phase II Letter for Public Comment.pdf

Hello,

On behalf of the Sustainable Tacoma Commission (STC), please find the attached letter regarding Home in Tacoma Phase II. This letter from STC is being submitted for the Public Comment period.

Thank you,



**LaKecia Farmer** (she/they)  
Senior Sustainability Analyst  
Office of Environmental Policy and Sustainability  
[Lfarmer2@cityoftacoma.org](mailto:Lfarmer2@cityoftacoma.org)  
(253) 625-4318



Sustainable Tacoma Commission

September 23, 2024

Dear Tacoma City Council,

The Sustainable Tacoma Commission (STC) would like to express broad support for the robust Home in Tacoma Phase 2 package developed by Planning staff and the Planning Commission. This plan represents a significant opportunity to create a more livable Tacoma — a city with thriving transit and active transportation options, diverse and affordable housing choices, improved work-life balance, clean air and water, and green spaces that support both environmental sustainability and community well-being. This Home in Tacoma Phase 2 package is a critical opportunity for the City to implement many of its strategies in its Climate Action Plan by its 2030 deadline.

The Home in Tacoma Phase 2 package will help the City enhance quality of life in the near term while also preparing to be resilient under a changing climate in the long-term, providing some of the necessary foundations for a more sustainable, inclusive, and vibrant community for residents, families, businesses, and the environment.

The science has shown how measures within the Home in Tacoma Phase 2 package can result in meaningful and transformative climate solutions needed to avoid some of the worst impacts of climate change in an equitable and just way. Delaying or failing to pass key elements within this package this year - especially when many of our peer cities are adopting these same measures to prepare for climate change - will likely increase the burden of climate change and climate-exacerbated stressors for Tacoma residents and businesses.

After reviewing the current proposal, we offer the following feedback:

1. **We strongly support the increased density and housing options proposed in the new Urban Residential (UR) zones.** The allowance for middle housing types and focus on locating denser housing near transit and amenities aligns well with the City's climate action goals. We encourage considering further density increases, particularly in UR-3 zones, to allow residents to live more efficiently and reduce the climate impacts of suburban sprawl, which aligns with Actions #9, #12, and #17 under the "[Better Living](#)" goal in the Climate Action Plan. To work, live, and play in the same area, we also

encourage incentives for commercial spaces. To work, live, and play in the same area, we also encourage incentives for commercial spaces.

2. **We urge stronger measures to ensure housing affordability and prevent displacement, enabling residents to remain in their communities.** To support this crucial goal, we recommend:
  - a. Streamlining the permitting process for affordable housing developments, such as Conditional Use Permits (CUPs).
  - b. Prioritizing tax exemptions for affordable developments that offer permanently affordable units, rather than those with limited 8 to 12-year affordability requirements.
  - c. Tying anti-displacement measures directly to the new zoning regulations by implementing intentional inclusionary zoning incentives, as outlined in the 2024 City of Tacoma Anti-Displacement Strategy by implementing intentional inclusionary zoning incentives, as outlined in the 2024 City of Tacoma Anti-Displacement Strategy.
3. **We commend the inclusion of strong tree and landscaping requirements in the plan.** These requirements are crucial for meeting housing goals while creating a healthy environment for all Tacomans. Strong tree retention requirements, rather than mere incentives, are necessary to grow Tacoma's tree canopy to your 30% by 2030 goal. Other cities in Washington, such as Lakewood and Vancouver, have implemented similar robust tree retention policies in pursuit of their own canopy targets. To ensure effective implementation of these new landscaping codes, the City will need to take additional steps in the future, including adding staff positions for proper enforcement.
4. **We strongly endorse the reduction or removal of minimum parking requirements, including the expanded Reduced Parking Area (RPA) proposal.** Reducing minimum parking requirements, especially near transit, is crucial for promoting sustainable transportation choices. Comparable cities such as Spokane, Washington, have removed parking minimums. We urge the Council to maintain progressive parking standards as they support your climate goals and can create space for meeting tree requirements. Additionally, we advocate for concurrent infrastructure improvements to ensure that facilities like sidewalks, bike lanes, and bus stops feel safe and comfortable for all users, particularly benefiting low-income residents who may rely more heavily on these options.

The current Home in Tacoma proposal represents significant progress towards creating a more sustainable, equitable, and livable city. Through strategic investments in transit corridors, support for middle housing options, protection of your urban tree canopy, and a strong commitment to affordability, we have the opportunity to shape a Tacoma that is more beautiful, sustainable, and inclusive.



The Sustainable Tacoma Commission looks forward to the successful implementation of Home in Tacoma and stands ready to support the City in this crucial endeavor.

Sincerely,

*Evlondo Cooper III*

Evlondo Cooper, Co-Chair

***Casey Twiggs***

Casey Twiggs, Co-Chair  
Sustainable Tacoma Commission

Cc:

Brian Boudet, Division Manager of Planning and Development Services

Christina Caan, Policy Analyst

LaKecia Farmer, Senior Sustainability Analyst

Kristin Lynett, Sustainability Officer

Elizabeth Pauli, City Manager

Geoffrey Smyth, Interim Director of Environmental Services

Alyssa Torrez, Senior Planner

**From:** Melanie Moor <memoor@me.com>  
**Sent:** Monday, September 23, 2024 2:15 PM  
**To:** City Clerk's Office  
**Cc:** heronmel50@gmail.com  
**Subject:** Written Comment: September 24, 24 meeting

To the City Council of Tacoma,

There are many roads I could take to describe my heartfelt observations of how Tacoma lacks a clear pathway toward actually increasing our tree canopy to 30% (when we're barely at 20%).

I choose this one today: Looking at increasing housing in our city does not mean that more trees need be killed/felled/removed. More people demands the need for more carbon cleaning that trees provide, more shade on sunny days that trees provide and more storm water filtration that trees provide.

Building without enforcing mature tree protections and planting when necessary would be detrimental to our collective well being and health.

Passing the Landscaping Code is vital to a healthy living environment for all Tacoma's.

Thank-you,

Melanie Moor  
Member of Tacoma Urban Forest Friends (TUFF)

**From:** Dmitry Lebed <dmitry@emeraldcitybuild.com>  
**Sent:** Monday, September 23, 2024 1:51 PM  
**To:** City Clerk's Office  
**Subject:** Submission of UR-3 Request Letter for Public Hearing  
**Attachments:** UR-3 Zoning Request for Parcel Number 0320333241 (Property Address\_ 8839 Pacific Ave, Tacoma, WA 98444).pdf; 240919\_8839 Pac Ave - Current Zoning Site Plan.pdf

Dear City Clerk,

I am writing to submit the attached letter and site plan in support of our UR-3 request, as per the instructions from the City of Tacoma. We are seeking to have this matter included in the upcoming City Council Public Hearing agenda on Tuesday, September 24, 2024, as part of the Home in Tacoma items.

Please find the attached letter and site plan for your review and inclusion on the docket.

Should you require any further information, feel free to reach out. I look forward to the city's consideration of our request, and I will be attending the hearing virtually.

Thank you for your attention to this matter.

Best regards,

--

**Dmitry Lebed**

**M:** 425-495-3188

**E:** [dmitry@emeraldcitybuild.com](mailto:dmitry@emeraldcitybuild.com)

2571 152nd Ave NE Redmond, WA 98052



**EMERALD CITY**  
CONSTRUCTION

CONFIDENTIALITY NOTICE - The information transmitted by this email is intended only for the person or entity to which it is addressed. This email may contain proprietary, business-confidential and/or privileged material. If you are not the intended recipient of this message, be aware that any use, review, retransmission, distribution, reproduction or any action taken in reliance upon this message is strictly prohibited. If you received this in error, please contact the sender and delete the material from all computers immediately.

Dmitry Lebed  
2571 152nd Ave NE  
Redmond, WA 98052  
Dmitry@EmeraldCityBuild.com  
425-495-3188

Date: September 5th, 2024

City of Tacoma Planning and Development Services  
Tacoma Municipal Building  
747 Market Street, Room 345  
Tacoma, WA 98402

Re: UR-3 Zoning Request for Parcel Number 0320333241 (Property Address: 8839 Pacific Ave, Tacoma, WA 98444)

Dear Larry and the City of Tacoma Planning Department,

I am writing to formally request that the property located at 8839 Pacific Ave, Tacoma, WA 98444, with parcel number 0320333241, be rezoned to UR-3 as part of the ongoing development process. I am working with Ferguson Architecture on this project, and we believe that rezoning to UR-3 will greatly benefit both the City and the community.

We are excited about Tacoma's \*Home in Tacoma\* initiative and the positive impact it will have on the city's growth. Given the property's location, we feel that a commercial development is not ideal for this site. Instead, residential development would better complement the surrounding area and fulfill the increasing demand for housing.

Thank you for considering our request. We look forward to continuing to work with the City of Tacoma to move this project forward.

Sincerely,  
Dmitry Lebed

# SITE PLAN

1/32"= 1'0"

AFFECTED PARCEL  
(#032033241)

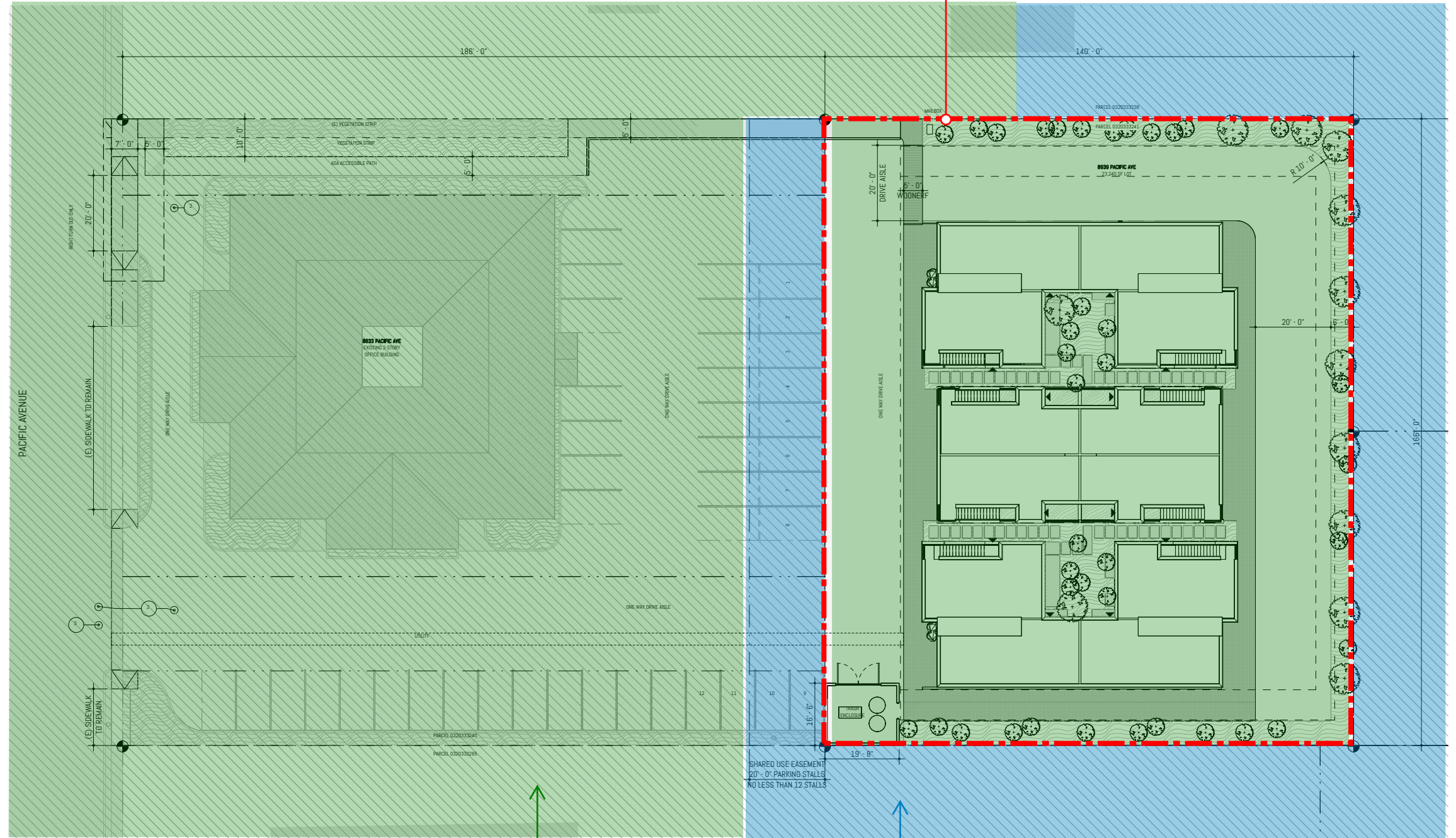

C-1 ZONING

R-2 ZONING

**From:** Courtney Bird <birdcourtney@gmail.com>  
**Sent:** Monday, September 23, 2024 2:45 PM  
**To:** City Clerk's Office  
**Subject:** In support of Home in Tacoma II

Good afternoon,

I am writing to voice support for Home in Tacoma Phase 2, particularly for landscaping and tree protections as we implement sustainable housing policies that benefit the City.

Trees are a vital resource for our community and protecting and building an urban forest is critical if we are to adhere to the City's stated goal of equitable climate resiliency. A single tree can reduce and filter up to 3000 gallons of stormwater runoff, protecting our surface waters and endangered salmon and orca from millions of pounds of toxins in our runoff. Trees improve air quality, sequester carbon, provide habitat, and access to trees improves mental and physical health of residents, both children and adults. During the 2021 heat dome, parts of Tacoma without much tree coverage experienced dangerously high temperatures. Protecting trees shows residents that the City cares about equitable health outcomes and values lives over immediate development profit.

It should be noted here that fostering a healthy urban forest ultimately will represent savings for Tacoma. In 2010, the State of Indiana Department of Natural Resources conducted a statewide street tree benefit study, which found that street trees alone (this is not counting trees on private property) provided \$79 million in stormwater management benefits. This number doesn't even account for air quality, carbon sequestration, health benefits, or the countless other impacts of trees.

I am fortunate to live in North Tacoma, in a neighborhood with access to beautiful trees. Some new, some old. My favorite running route takes me along Ruston Way and back up through the Puget Creek Ravine. In the summers, I feel a palpable drop in temperature as soon as I enter the forested ravine. In the winter, I feel the rain slow or even cease as the tree canopy intercepts it. Either way, being in the trees is a relief and makes my run enjoyable. Trees encourage recreation and community building. With health disparities terribly high across underserved parts of Tacoma, we need to provide outdoor space that protects, embraces, and invites. My children play under a great big cedar when they need shade in summer or protection from the rain in winter. We must protect these kinds of opportunities for every child and adult in Tacoma. It is imperative as we look to the future of our city.

As a Pacific Northwest community in the heart of the Puget Sound, trees are our inheritance. With Home in Tacoma II, we have the power to make them our legacy.

Thank you,

Courtney Bird  
2906 N Mason Ave  
(908) 578-0882

**From:** Brianna Pfeninger <bripfen@gmail.com>  
**Sent:** Monday, September 23, 2024 2:59 PM  
**To:** City Clerk's Office  
**Subject:** Home in Tacoma Public Hearing written comment 9/23/2024

My name is Brianna and I have been a homeowner in Tacoma for the past 12.5 years and have worked in Tacoma for the past 15 years.

It pains me to write this email, as I have lost all respect for the current Mayor and council and I know that they will vote to approve what they want, no matter how their constituents feel.

The proposed Home in Tacoma zoning changes needs to be decided by a vote of the citizens, or at the very least scaled back and implemented differently. The council is so out of touch with reality and more concerned with passing new ordinances and proclamations that 'look good on paper' but translate poorly to real life.

Despite what you have all said, a majority of Tacoma residents are not aware of the proposed HIT. The mailings that were sent out did not truly and accurately convey the huge impact of this.

It seems like anything that is done, is for the benefit of contractors. Tax breaks? Not requiring parking spaces, so they can cram in as many units as possible? How much of the infrastructure upgrades that will be needed for more residents will be paid for by the contractors? Or will it all come down to the taxpayers of Tacoma?

Our neighborhoods will be destroyed. What is stopping contractors from buying up every home for sale, tearing it down so they can build a bunch of units on the property, thus lining their pockets further? When will it stop? Homes will be of no value, only the land that they sit on.

How do more units for rent increase generational wealth? It doesn't. There needs to be requirements on a MINIMUM number of homes FOR SALE.

What is affordable? Apparently no one knows. I've recently heard about some new units being built in Tacoma, with tiny studios starting at over \$1000. How is that affordable to anyone?

Parking needs to be required, or our neighborhoods will become just like Seattle's.

**The City can't support its current residents, how will they be able to support an increased population?** Our infrastructure is failing and not adequate to support millions more people.

Salishan-type communities is not something we should be aiming for. Creating a dense neighborhood of renters who aren't invested in their neighborhood and community, has brought on violence and blight. You can build those cheap buildings that will look nice for a few months until they start falling apart. How long until Salishan needs to be rebuilt?

Having towering buildings built uncomfortably close to existing homes is wrong. Who wants the apartment dwellers next door looking down into your home windows? People do like their privacy and to have their own private spaces. Imagine having a 'shared yard' with a bunch of other families who don't clean up after themselves.

The only ones who will be winning will be the contractors.

**The current council has created their legacy. They are the ones that destroyed Tacoma.**

Lastly, I'd just like to point out that Jamika Scott is a clown, an absolute shame to our City and should be fired.

Thank you,  
Brianna

**From:** J Corso <jcorso695@gmail.com>  
**Sent:** Monday, September 23, 2024 3:17 PM  
**To:** J Corso  
**Cc:** City Clerk's Office  
**Subject:** Home in Tacoma-Phase 2: Oppose

Dear Mayor Woodards and City Council Members,

I want city staff and the city council to plan for the future. However, I'm disappointed with the HiT Project, both in terms of the planning process and the resulting plan.

#### Dreams of Gentrification

City staff and city council members have been working to gentrify Tacoma for decades, dreaming that one day Tacoma households will be wealthy enough to attract high-end retail (e.g., Whole Foods, Trader Joe's, William-Sonoma, Coach, West Elm, etc.). Unfortunately, city staff and the city council appear to be little concerned that gentrification will displace a large percentage of Tacoma's poorest residents and their constituents. While I'm happy that the city council (finally!) passed an anti-displacement ordinance in February, this is an ordinance that the council could have passed a decade ago. The delay in passing the anti-displacement ordinance speaks volumes about the priorities of city staff and the city council. Given that gentrification requires displacement, I'll be watching how the city balances these competing priorities.

#### Pierce County Buildable Lands Report

City staff disregarded the conclusion of the Pierce County Buildable Lands Report which states that there's enough buildable land in Tacoma to build enough housing units to accommodate the anticipated population growth during the next 15- 25 years with the current residential zoning. That is, before E2SHB-1110, there was no need to upzone land designated for residential use.

#### Real Estate Investors, Builders and Realtors

City staff asked real estate investors, builders and realtors what it'll take to motivate them to build housing in Tacoma. This, in and of itself, is not the problem. The problem is that the real estate community doesn't want most of the vacant, buildable land. Instead, they want to reduce their risk by acquiring land in the most popular neighborhoods, and they want the city to deregulate the land use policy. Deregulating land use policies will result in the value of the land increasing at an accelerated rate, increasing the overall cost of housing, and displacing the residents who can no longer afford to live in these neighborhoods. Again, it'll be interesting to watch how you balance the demands of the real estate industry with the anti-displacement ordinance.

#### Tacoma Residents

City staff divide residents into two groups (i.e., one of us vs one of them). The residents who share the city staff's vision for the city are awarded seats on the various commissions, committees and boards while other applicants, who might be "problematic" (e.g., older, white, cisgender men who live in the wealthier parts of the city) who are otherwise well-qualified, are denied a seat on these same commissions, committees and boards. Effectively, the city council is supporting staff's effort to disenfranchise most of their constituents. This decision has set the stage for constant conflict as the "in-group" drafts the plan and mostly ignores the "out-group's" questions, concerns, counter proposals and recommendations. Now, the "out-group" feels no ownership of the plan, and some are motivated to continue fighting it. You've created a political mess! How are you going to resolve it?

#### WA State Legislature

The City of Tacoma lobbies the state legislature for housing bills (e.g., E2SHB-1110) that supports the draft HiT1 Project plan. Now, despite the conclusion of the Pierce County Buildable Lands Report, city staff and the city council can attribute the need for the HiT Project to state legislation. Clearly, city staff and city council are using the legislation to redirect criticism from themselves to the legislature. However, you should remember that those of us who are familiar with the HiT Project timeline aren't fooled, and the misattribution of responsibility communicates an unsavory message.

#### EPA Responsible Official

[WAC 197-11-910](#): requires the City of Tacoma to designate a "Responsible Official" (RO) for the HiT Project, and Peter Huffman is the designated RO. However, it's unclear whether Mr. Huffman has been trained to perform the duties of an RO or has



chosen to neglect some of his duties, particularly regarding his effort to involve the public in the preparation of the EIS. An RO must make reasonable efforts to involve the potentially affected community where the proposed action is expected to have environmental impacts or where the proposed action may have human health and environmental effects in the community. Yet, Mr. Huffman was absent from most HiT Project meetings where he could have been fulfilling his duty to exchange information with the community, and he chose not to delegate this responsibility. I'm aware of him attending only 1 Zoom meeting and 1 in-person meeting, but he was not present at the approx. other 10 HiT Project meetings that I attended.

### Environmental Impact Statement

Given the history of Tacoma, and particularly its history of heavy industry, concluding the Environmental Impact Statement (EIS) for the HiT Project with a Determination of Nonsignificance is incredible. We know the Asarco Smelter alone discharged dozens of chemicals into the air. Tacoma soil has been tested for only lead and arsenic, and these chemicals are present in elevated quantities in areas of the city. What's the remediation plan for them? As far as I'm aware, Tacoma soil hasn't been tested for elevated amounts of all of the dozens of other chemicals, so the "Determination of Nonsignificance" lacks convincing supporting evidence. Further, the EIS fails to address whether any of the chemicals are water soluble and whether surface water or groundwater is redistributing them in the soil, concentrating them in the soil, and/or carrying them into the Sound. In addition, the smelter waste product, slag glass, was distributed across the city. For example, it was a popular landscape mulch used on driveways and parking pads because it suppressed the growth of weeds, yet the EIS doesn't address this contaminant either. Again, the EIS DNS is unconvincing.

When I see people working in the dirt (e.g., rebuilding the streets south of 6th Ave.), I wonder whether they're aware that they may be exposing themselves and their families (e.g., wearing dirty clothes home) to contaminants from Tacoma's past heavy industries. Not only will construction workers and their families risk being exposed to contaminants, Tacoman's living near the construction sites risk exposure too. Given that the city infrastructure is built to meet only the demands of the current population in an effort to keep costs low, it's likely that City of Tacoma and Tacoma Public Utility blue collar workers may be risking their health as they upgrade the city infrastructure. Is the HiT Project more important to city staff and the city council than the long-term health of Tacoma's blue collar workers?

### Health Impact Assessment

While I applaud the Tacoma-Pierce County Health Department for the HiT Project Health Impact Assessment, I don't understand why the report doesn't include a section about the chemical pollution from past heavy industries that remains in Tacoma's soil. Given all of the anticipated dirt work (e.g., demolition, excavation, trenching, etc.), I expected the assessment to say something about the risks of exposure to the dozens of chemicals discharged from the Asarco Smelter smokestack as well as the slag glass that has been distributed across the city.

### Conclusion and Recommendation

During my first 10-years after high school, I rented my housing and needed roommates to afford housing. During the past 30 years, I've lived in the most populated neighborhoods in the state (i.e., Seattle's Capitol Hill and Tacoma's North Slope Historic District). Both neighborhoods were street-car neighborhoods that were mostly built-out before either city implemented single-family zoning, so there has always been a mix of single-family and multi-family housing with a smattering of commercial buildings. Currently, there are 40 housing units on my block, and only 8 are owner-occupied. The 32 households who were renting their housing have all been displaced since I moved here because the 3 apartment buildings on the block have been sold and renovated. My neighbors in the Chinook Apartments have been displaced twice in the past 2 decades.

Gentrification is a traumatic experience for residents, and city staff and the city council appear to be prioritizing the demands of the real estate investors, builders and realtors above the needs of current residents and constituents. Further, city staff appear to be carefully controlling - and basically suppressing - public discussion of the HiT Project and have created a political mess. I propose putting the HiT Project on an upcoming ballot for an advisory vote, so we can have a city-wide conversation about the anticipated advantages and disadvantages of this plan from perspectives as diverse as your constituencies. I want to hear what other Tacomans think about the proposed housing policies and code, and I want to learn whether city staff and the city council have the support of a simple majority of Tacoma voters.

Sincerely,  
John Geoffrey Corso  
701 N J St  
Tacoma, WA 98403



**From:** STNC Board Info <stnc253info@gmail.com>  
**Sent:** Monday, September 23, 2024 2:53 PM  
**To:** City Clerk's Office  
**Cc:** Woodards, Victoria; Hines, John; Rumbaugh, Sarah; Scott, Jamika; Sadalge, Sandesh; Bushnell, Joe; Daniels, Kiara; Diaz, Olgy; Walker, Kristina  
**Subject:** Comments re: HIT II 9/24/24 Public Hearing  
**Attachments:** 9-23-24 STNC - HIT II.pdf

Hello,

Attached is the public comment submitted for the Sept. 24, 2024 Public Hearing regarding "Home in Tacoma, Phase II" for which we strongly recommend that this council does not approve.

Thank you for reading and considering our comments,  
South Tacoma Neighborhood Council

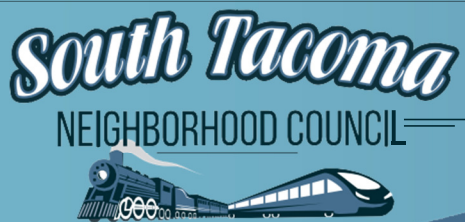

Sept. 23, 2024

RE: Public Hearing, September 24, 2024

Recommendation: Do not pass "Home in Tacoma Phase II"

*"Don't cling to a mistake just because you spent a long time making it." ~ Aubrey de Graf*

To Mayor Woodards and the Tacoma City Council,

The South Tacoma Neighborhood Council Board supports policies to ensure affordable housing; however, Home in Tacoma Phase II does nothing to meet such goals.

We have repeatedly requested verifiable sources to support assurances of affordability but have received none. Conversely, among the cities which have already tried such up-zoning, housing costs have actually increased.

Despite the false cover slides on many of the City presentations, it was admitted in numerous meetings that simply "more housing" will not equate to affordable housing especially for low-income individuals much less families, and certainly not the unhoused. Instead, we foresee great harm from such a policy within Tacoma's most vulnerable and overburdened communities.

Now that the state has finalized the Engrossed Second Substitute House Bill 1110, there is no reason to force this wildly experimental HIT Phase II upon us. The state policy is already a drastic change to absorb, itself, and should be applied before pushing through this more extreme, untested, policy within our city.

No other place in the United States has proposed rezoning an entire municipality to allow for multi-plexes city-wide and especially not 3-4-5 story apartment buildings in currently single-family-home areas for up to 16-units, with no consideration for distinctive neighborhoods or tree canopy, to preserve the very reasons people want to live there.

Instead, as currently written, this seems promoting demolition for density-sake, which offers few benefits to the residents who have invested in and love this city. If density is the goal, there should be careful and controlled growth, not this kind of broad blanket rezoning.

Other cities have suffered the folly after even more cautious up-zoning than presented here. Seattle only up-zoned six-percent of single-family neighborhoods (which took many years with full public awareness and input), yet is seeing strains on its infrastructure and first responders, as well as irreversible losses of historic structures, green space and quality of life.

We should also be reviewing lessons learned within our own city, looking no further than the poor results within the Tacoma Mall Subarea. Such designated growth centers should be first followed-through on and perfected before being pushed-out farther.

Even after achieving success within growth centers, there's no reason to immediately up-zone the entire city in this excessive way.

On September 14, 2021, Mayor Woodards spoke of "growing responsibly" in the "correct places" which "Home In Tacoma" does not do. "Home in Tacoma" is not focusing on neighborhood characteristics, is not requiring building only on vacant lots or primarily using existing buildings first, but is instead a sweeping city-wide massive up-zoning unlike seen anywhere.

The previous buildable lands report stated that Tacoma has ample sites to accommodate expected growth without any need to rezone and demolish existing homes. The greenest building is reusing an existing building, so there are many better ways to preserve live-able neighborhoods, create density and affordable housing, other than by simply hoping it will be achieved by the for-profit builders while only "discouraging" demolition. Tacoma must provide more clear and enforceable policy.

In addition, South Tacoma is currently suffering present-day discrimination in the form of highest illness and highest mortality rates in Pierce County, largely due to air pollution/fine particulate matter from increasing diesel and other Industrial, housing and traffic congestion. It is inappropriate to press for any further housing density in an area already struggling with inordinate health and environmental issues. Doing so is the definition of Environmental Injustice.

"Home in Tacoma" is essentially handing-over our neighborhoods to become an experiment on a massive scale with all control (and subsidies, no less) to the for-profit developer/builders, no guarantee of affordable housing, while possibly damaging the very communities we are striving to improve.

So, as one of the most diverse and low-income neighborhoods in the city, we do not see "Home in Tacoma" as correcting a housing issue for the disenfranchised but, in fact, foresee this proposal as again taking advantage of the most marginalized people by forcing them into congested housing of crowded overpriced rentals, with less green space and more pollution, while reducing and removing opportunities for those of low-income to purchase homes or gain equity.

Instead of affordable housing, "Home in Tacoma" seems poised to enact a whole new form of elitism where tax-payers will be subsidizing developers' tax-breaks by our shouldering the later costs of increased infrastructure, loss of trees and livability, while also making it likely impossible for even an average person to purchase a home if being outbid by developers' intention to demolish houses for building private profitable multi-plexes, thus limiting options for many and forcing renters-for-life and costs not within their control.

Before such a significant change was even considered, there should have been detailed policies in place to confirm the ongoing claims. For example, in addition to assurances of affordability, where are the studies and estimates regarding required increases and budgeting of city hiring and other costs due to proportional population growth?

Besides seeing very little benefit to residents from such uncontrolled growth methods, Tacoma must also consider these other very real environmental consequences:

- Loss of trees and green open space results in loss of soil stabilization, heat and water run-off management.
- Loss of mature trees also disrupts the upper canopy for birds and other urban wildlife.
- Loss of historic homes and solid structures replaced with cheap construction, requiring frequent rebuilds.
- Demolition debris is already the largest contributor to our already full and overflowing landfills.
- Paved-over and box-building properties result in more and untreated stormwater runoff.
- Less water infiltration reduces aquifer recharge which is critically important as fresh water becomes more precious due to climate change.

Tacoma is also already out-of-compliance regarding wastewater nutrient levels due to outdated treatment technology. This city has been aware of that issue for years, unacceptably pushing the problem to future councils. That should be a basic baseline which must be corrected before any further housing growth can be considered. To move forward with "Home in Tacoma" without resolving this would be deliberately irresponsible and knowingly creating even more of an environmental disaster for Puget Sound.

The proposed permanent and wide-spread changes of “Home in Tacoma” is much more than just a simple zoning change. It represents a massive reimagining of the entire city which should require in-depth studies of both short and long-term resource sustainability. Based on the population influx levels being discussed, an Environment Impact Statement should be completed for each area at every stage of growth. Instead, every health caution from the current EIS seems to have been completely dismissed.

Continued unanswered questions:

Impacts from the mega-warehouse (traffic congestion, road safety, air/water/soil/light/noise pollution, loss of urban wildlife habitat, increased heat zones) have not been adequately included in considerations of increased density into this area.

Rezoning to allow multiple units raises assessor questions, future title confusion and possible complications for existing homeowners/sellers from residential to commercial.

Lingering questions regarding:

- lot density bonuses
- separation between structures
- ability to sell individual units
- reducing parking areas prior to appropriate transit alternatives
- impossibility of meeting city assurances of communal amenity and community park/green spaces

Such a momentous change (not only in building scale, but also reaching city-wide), should have broad agreement in the form of a ballot vote; however, most residents are not yet even aware of this proposal and its substantial impacts. The City’s communication includes only cartoon or stock photo images, and another mailed communication (a private propaganda postcard, paid for by the Tacoma Pierce County Association of Realtors) displayed a photo of single-family houses among mature trees which wrongly presents precisely what “Home in Tacoma” will eliminate.

To quote the mayor again, this is not “getting our arms around” the affordability issue -- this is a for-profit developer free-for-all which residents will unknowingly later be paying the price for in many ways.

We request rejecting “Home in Tacoma Phase II, since “affordability” will never be achieved through developer tax-breaks and for-profit construction; it would instead be best done by simply following the state guidelines, utilizing currently vacant property, city-purchased buildings, and careful deliberate neighborhood-by-neighborhood considerations which the current and future-residents of Tacoma deserve.

Respectfully,  
South Tacoma Neighborhood Council Board

CC: City Clerk,  
City Council Members

South Tacoma Neighborhood Council, PO Box 112196, Tacoma, WA 98411 / [board@southtacoma.us](mailto:board@southtacoma.us)

**From:** Jill Sousa <jill@jillsousaarchitect.com>  
**Sent:** Monday, September 23, 2024 3:26 PM  
**To:** City Clerk's Office  
**Subject:** Home in Tacoma Comments

I am generally very supportive of greater density and alternative housing options within the City of Tacoma. I do, however, have concerns about new code:

Has there been analysis/discussions with small developers that may be able to do Missing Middle size projects? The reality that there is an economy of scale has to be addressed. I think the fabric of the city is ruined when lots are aggregated so that larger block-size or greater developments happen. But this is a common

Generally I think the new code will require more soft costs (architect, surveying, tree consultant/landscape architect, civil engineering) that larger projects will more easily be able to afford.

How have Public Works and utilities been integrated into the landuse planning? Often these are harder issues to deal with

1) cost of hookups/ connection requirements

2) Clarity of regulations that impact development as much as zoning and should be easily accessed:

setbacks in alleys from powerlines

trash and recycling needs, location on site

3) when will alley improvements be required for backyard building. I have permitted lots of ADUs and have not yet had to pave alleys but I can see that it is possible (perhaps desirable) in near future and would add to costs.

I find it odd that this new "form based" code was added in for the UR zones, without getting rid of the R4 and R5 zoning. Makes everything messy.

Additionally I think the building valuations and landscaping/tree canopy requirements might make small remodel/additions to single family structures more onerous and expensive, driving up costs. I find pretty much every client needs to have their property surveyed, adding \$2000-\$3000, which is a huge change from even a few years ago.

A few minor issues:

FAR calculations are not going to be straight forward for existing homes - to know what is included and what not (basements, attics) and I seems possible there will not be consistency. I spent many months working out what was considered living space in an ADU with code reviewers (certain size decks were included as living spaces as well as porches but not stairs and landings up to an upper unit, ie) in the last few years. I understand FAR does not include these, but does the max 1000 sq. ft for an ADU still include them?

It would be nice for a definition of DBH to be included in code

There appears to be two 13.06.020 H sections (accessory building standards and Townhouse)

Can the on-line code have floating headers so it is clear what section you are in when scrolling through it?

Thanks for taking comments,  
Jill

Jill Sousa  
jill@jillsousaarchitect.com  
253.468.9662

**From:** Michael Holloway <mchhol@gmail.com>  
**Sent:** Monday, September 23, 2024 3:27 PM  
**To:** City Clerk's Office  
**Subject:** Home in Tacoma

> Hello, my name is Michael Holloway. I live in Old Town Tacoma and I'm very concerned about the changes proposed in the Home in Tacoma rezoning plan.

>

> I'm worried that the changes to the zoning will cause negative effects on my neighborhood. There is a rich history of the beginnings on Tacoma in my area and I think increasing the population density will dilute that history and crowd out many of the historic homes and buildings.

>

> I'm also very concerned with the increased population density and the infrastructure to support it. There are virtually no four lane roads that serve the new increased density zones. Traffic can already be a problem in the north end. How does adding more people and cars serve to better all residents.

>

> I really hope you can reconsider this initiative and champion infilling where we have vacant land while maintaining our historic areas.

Michael Holloway



**From:** LAURA CASTRILLI <castrilli.laura@comcast.net>  
**Sent:** Monday, September 23, 2024 3:31 PM  
**To:** City Clerk's Office  
**Subject:** Home in Tacoma public comment

To whom it may concern:

I object to the proposed UR-3 zoning for McKinley Avenue between 38th Street and 64th Street. I also object to the UR-2 proposed zoning for the rest of the block/blocks immediately east and west of McKinley in the same area.

McKinley Avenue is a two lane road with occasional turn lanes. At the current population density, the traffic on McKinley Avenue, especially the 3 or so hours in the morning and the 3 or so hours in the evening is bad.

Removing the 4 way stop at 64th didn't help much as now turning east or west on a red light is prohibited due to the bicycle lanes that eventually will extend further east of 64th and McKinley.

The 56th street and 38th street perpendicular east/west arterials are even more heavily used. It still takes two light cycles to pass through or turn left onto 38th and 56th from McKinley during rush periods.

Given the current push by major employers to have their employees return to the office, increasing the number of people who presumably will be working, would be misguided unless the City first fixes the traffic bottlenecks along McKinley Avenue. Perhaps light rail could be run along McKinley and once Sound Transit breaks ground on that build in 15+ years we could then start building more multi family units along McKinley. Until then, please keep the density and codes we currently have in this area.

Bus service along McKinley is not frequent enough nor does it run early enough and late enough for commuters to consider it a reliable option for getting to and from the Tacoma Dome Station. Commuters already facing a long commute to Seattle don't want a haphazard connection back up McKinley to get home.

I commuted from Tacoma to Seattle from 1990 to 2020. COVID enabled remote work until I retired near the end of 2021. I drove to the nearest park and rides (320th, then Tacoma) to catch express buses into Seattle.

I purchased my Eastside home in 1992. I was raised in the Hillsdale area and am familiar with rush period traffic from TDS to my late parents' home. For years, I was picking up a puppy they were watching and/or cooking them a meal after a long commute and work day.

Laura Castrilli  
847 E 46th Street  
Tacoma, WA 98404  
253-209-9058

**From:** Ellen Garay <ellengaray123@gmail.com>  
**Sent:** Monday, September 23, 2024 3:31 PM  
**To:** City Clerk's Office  
**Subject:** Home in Tacoma Phase 2

Hello,  
My name is Ellen Garay and I currently reside in the Hilltop neighborhood of Tacoma. I have been keeping up with the progress and recent developments of Home in Tacoma, and wanted to write to urge the City Council to adopt the recommendations of the Planning Committee for the implementation of Phase 2 of Home in Tacoma. As a Hilltop resident, I have seen the way a sudden influx of private investment in Tacoma has left thousands of people to be housing insecure.

Passing Home in Tacoma Phase 2 is crucial to addressing the housing crisis in Tacoma, and building a more livable, green future for our city.

Thank you,  
Ellen Garay, City Council District 3

**From:** Deborah Cade <dlcade@comcast.net>  
**Sent:** Monday, September 23, 2024 3:33 PM  
**To:** City Clerk's Office  
**Subject:** Comments on Home in Tacoma -- Please Oppose

I'm writing to express my strong opposition to the Home in Tacoma program that is the subject of tomorrow's public hearing before the City Council.

In developing initiatives for new housing, there are several areas that the City has failed to address despite them being raised multiple times in public meetings and comments:

1. There is still no regulation of or limit on short-term rentals. My neighborhood, the North Slope neighborhood, is full of homes, primarily smaller homes, that are held by investors as short-term rentals. Often, these are rented for only a few days a month and sit vacant the rest of the time. All of these homes could be available as long-term rentals or as starter homes for first-time home buyers or for those seeking to downsize. Yet here they sit empty much of the time. The City so far has been unwilling to address this as part of the housing shortage despite it being a known problem for some time.

2. Despite all of the talk (and much of it is just talk) about equity, the City has carved out large portions of the city's residential neighborhoods for view protection, making them far less attractive to developers who would be subject to severe height restrictions. Added to that, many of the neighborhoods built after 1940 or so were covered by restrictive covenants. While the racially restrictive language in those covenants has not been enforceable for decades, the provisions limiting development in those neighborhoods to single family homes only is still in effect and is still enforceable. Yet, when I have raised this with planners, they shrug and say that they have no idea where those neighborhoods or covenants are. This focuses the demolition and redevelopment in inner city neighborhoods with older homes built prior to the use of covenants, and without views.

3. There is no regulation of corporate ownership of housing. While we have less of a problem with this than other parts of the country, we have no reason to think that it won't catch up here. Homebuyers can't compete with corporate buyers.

4. There has been little to no consideration of how much of our commercial land, particularly that devoted to strip malls, could be converted into mixed housing and retail, in the way that the Proctor neighborhood has been redeveloped. These strip commercial developments are on arterials that can absorb the traffic generated as well as on bus routes, have land available for parking, and could absorb much more intensive development than our already-dense older residential neighborhoods.

Please take a step back and consider some of these as well as likely many other creative solutions that could provide additional housing stock in Tacoma while preserving our older, more affordable, and irreplaceable inner-city residential neighborhoods.

Deborah Cade  
908 North M Street  
Tacoma, WA 98403

**From:** Anna Huber <arh925@gmail.com>  
**Sent:** Monday, September 23, 2024 3:38 PM  
**To:** City Clerk's Office  
**Subject:** Home in Tacoma Phase 2 Written Comment

Hello,

My name is Anna Huber, and I live and work in the Hilltop neighborhood. I am writing to urge the city council to adopt the full zoning and landscaping recommendations of the Planning Commission for the implementation of phase two of Home in Tacoma. Our region and our city is facing a housing affordability crisis, which is fueling displacement, which I feel particularly in my Hilltop neighborhood. I see the effects of this every day in the lives of my friends, neighbors, and clients at work. They all are having to make the terrible decision to leave behind their communities, and support systems to find more affordable housing elsewhere. Allowing denser, affordable housing is a much-needed solution in the fight against displacement across Tacoma. Hilltop should be a safe home for those who live here and have lived here. Displacement and pricing people out doesn't equate to safety for Hilltop, it further throws salt in the wounds of our neighbors who need our support the most. The recommendations of the Planning Commission also align with the City's Climate Action Plan, by reducing sprawl, ensuring development is located in areas with the infrastructure that can support it, and preventing further inequitable environmental consequences of development that has become a pattern in Tacoma and elsewhere.

The landscaping recommendations of the Planning Commission are also crucial to implement, as they can preserve our existing tree canopy alongside the encouragement of further housing development. This type of planning is essential for the legitimacy of the city of Tacoma, as we are starting to feel the harmful effects of climate change around us. Even if the City accelerates urban tree planting programs, current mature trees are critical to protect when developing new housing. Trees are critical infrastructure - they provide clean air, reduce the impacts of urban heat waves on our most vulnerable neighbors, help mitigate stormwater runoff into our watershed, and promote neighborhood cohesiveness. All very important and exciting stuff that would be wonderful for the city to support.

Passing Home in Tacoma Phase 2 is crucial to addressing the housing crisis in Tacoma, and building a more livable, green future for our city.

Thank you,  
- Anna Huber, City Council District 3

**From:** Elie Flanagan <elieflanagan00@gmail.com>  
**Sent:** Monday, September 23, 2024 3:49 PM  
**To:** City Clerk's Office  
**Subject:** Written Comment: Pass Home in Tacoma Phase 2!

Hello,

My name is Elie Flanagan, and I live in Hilltop. I urge the City Council to adopt the Planning Commission's **full** zoning and landscaping recommendations when implementing Phase Two of Home in Tacoma. Our region and our city is facing a housing affordability crisis, and here in Hilltop we are really feeling the push to leave as prices rise, and seeing it play out in real time. The building that just went up across the street from me charges almost \$1400 per month for a studio apartment--it's not sustainable, and for families the issue is even worse. My friends and neighbors are having to make the terrible decision to leave behind their relatives, friends, communities, and support systems to find more affordable housing elsewhere. Allowing denser, affordable housing is a much-needed solution in the fight against displacement across Tacoma. The recommendations of the Planning Commission also align with the City's Climate Action Plan, by reducing sprawl, ensuring development is located in areas with the infrastructure that can support it, and preventing further inequitable environmental consequences of development that has become a pattern in Tacoma and elsewhere.

I know some have been hesitant to densify the housing here because they feel single-family homes have more "character," but I think they are failing to understand that the character of our neighborhood comes from the people and small businesses that have built it into what it is, not just the houses themselves. Nobody deserves to be priced out of their home for an aesthetic complaint, and it feels insulting and frankly discriminatory to suggest otherwise.

The landscaping recommendations of the Planning Commission are also crucial to implement, as they can preserve our existing tree canopy alongside the encouragement of further housing development. The best time to plant a tree was ten years ago - even if the City accelerates urban tree planting programs, current mature trees are critical to protect when developing new housing. Trees are critical infrastructure - they provide clean air, reduce the impacts of urban heat waves on our most vulnerable neighbors, help mitigate stormwater runoff into our watershed, and promote neighborhood cohesiveness.

Passing Home in Tacoma Phase 2 is crucial to addressing the housing crisis in Tacoma, and building a more livable, green future for our city.

Thank you very much for your time,

- Elie Flanagan, City Council District 3

**From:** Torrez, Alyssa  
**Sent:** Monday, September 23, 2024 3:50 PM  
**To:** City Clerk's Office  
**Subject:** HIT Public Comment

Please note the below comment received via voicemail for the Home In Tacoma Public hearing.

Sue Schanbacher, 910 S Proctor

I would like to express my displeasure with the new HIT proposal. The public hearing notice was vague enough so people would show little interest. I've read the proposal and the idea that people can put up 6 units on a single lot even if its short platted and then make variances for parking and trees and just remove everything and basically make our city a solid block of concrete is not going to be beneficial to us. We are not addressing the housing shortage problem by doing this. We already have a ton of housing going in and its certainly not helping homelessness at the percentage you are requiring it and there doesn't seem to be the protective parameters for what things must be built out of to make them match with the neighborhood. No effort on making parking reasonable, people will take all of the street parking it's just not going to benefit us. I have lived in this neighborhood and owned this house for over 40 years and this project seems to be one of the worst possible for destroying home values and upping crime rates, taking away parking and not addressing the issues of lowering rents, not going to address the issue of homelessness, and I think this is a very poorly thought out plan. Please note that I hope the city council will vote against it and as a society realize our priorities need to be on there's a need not just on developers getting extra money out of it.

**From:** Elizabeth M <mcleee4788@gmail.com>  
**Sent:** Monday, September 23, 2024 4:06 PM  
**To:** City Clerk's Office  
**Subject:** Public Comment HIT 2

Please take into account all the extensive community feedback from HIT 1 (and the public comment to the planning commission in HIT 2). In HIT 1, the planning commission initially proposed a plan to the City Council that went well beyond what the voting citizen feedback actually supported. Thankfully the Council listened to the voters (and not just special interest groups) and scaled the planning commission's plan way back to something that the voters had a much easier time supporting.

Now the planning commission has again proposed a plan that does not reflect the feedback of voters with regard to zoning (specifically UR-2 and UR-3). I ask that the City Council again listen to voters and not just special interest groups and scale back the zoning of UR-2 and UR-3 to reflect what is required under state law, and not expand UR-2 and UR-3 zoning beyond what the new state law already requires for zoning density.

Please listen to the voters, re- review the comments from HIT 1. The zoning areas are already a huge change based on new state law. Start with the state mandated density requirements, see how the actual law works (not just hope you hope it will work), then expand zoning if the state law actually works and is supported by Tacoma voters.

Also, please stop saying this plan will create affordable housing. It will create more market rate housing. The way this has been presented as an affordable housing plan is misleading and undermines trust.

Separate from the issues with UR-2 and UR -3, don't allow businesses to operate in residential areas (especially if no additional parking is required). Do protect the tree canopy. All Tacomans should have the benefit of trees. Add in more traffic calming measures in all areas.

Thank you,

Elizabeth

**From:** mike elliott <mike.elliott.wslb@gmail.com>  
**Sent:** Monday, September 23, 2024 4:03 PM  
**To:** City Clerk's Office  
**Cc:** mike elliott  
**Subject:** Home in Tacoma Comments  
**Attachments:** Comments\_HIT\_Zoning&Standards\_16September2024.pdf

Dear City of Tacoma Clerk,

Please accept my comments for the Home in Tacoma Zoning & Standards.

Thank you,  
Mike Elliott  
3301 N Shirley Street  
Tacoma, WA  
(253) 820-4288



Date: September 16, 2024

To: Tacoma City Council

From: Mike Elliott

RE: Home in Tacoma Zoning and Standards Package, as recommended by the Tacoma Planning Commission.

To Whom It May Concern:

I am a Tacoma resident and live in the West End Neighborhood Council (WENC) area. I have followed Home in Tacoma (HIT) for over a year, participated in the WENC discussions involving HIT, and provided input to city planning staff at the HIT open house at Silas High School earlier this year. Unfortunately, my concerns and those of many other residents living in the WENC area have been ignored.

First, I agree more affordable housing is needed EVERYWHERE. However, HIT is NOT the answer. The concept has been forced onto citizens with their input and recommendations being ignored. A prime example is the 33<sup>rd</sup> Street development (see Application SDEV23-0030). In the case of the 33<sup>rd</sup> Street development, I and many other concerned citizens pointed out the serious public safety shortcomings during public commenting opportunities under both the planning and permitting stages of the development. Guess what? Those comments went in one ear and out the other at Tacoma Planning and Permits.

One of the most glaring safety concerns never addressed was the intersection of 33<sup>rd</sup> Street & Pearl Street. The developers, not the public, should have been saddled with improving safety at that intersection for both pedestrian and vehicle traffic attempting crossing and merging activities. But as it stands today, neither the developers nor the city has taken steps to add the infrastructure necessary for public safety. FYI, I hired a professional traffic engineer, with 40+ years of experience to testify at a hearing before the Tacoma Hearing Examiner. The expert testified as to the need for additional public safety traffic improvements at 33<sup>rd</sup> Street & Pearl. But the city defended the planning department's poor decision and allowed the permitting package to advance without adding safety measures at the 33<sup>rd</sup> Street & Pearl Street intersection. Not even the most basic, cost-effective safety improvements, i.e. painted crosswalks and a turn lane extension, were approved by the City of Tacoma. Unfortunately, and needlessly, it is only a matter of time before someone loses their life at the intersection of 33<sup>rd</sup> Street & Pearl because the City of Tacoma refused to listen to Tacoma residents who live, work, and travel these neighborhood streets every day.

As for comments regarding the HIT Zoning and Standards package as recommended by the Planning Commission – it is insufficient, incomplete and should not be approved by the City Council. The WENC has spent many hours listening to residents and contemplating how to best move forward with more housing density in the West End

Neighborhood. Safe, sane, and sensible planning and permitting have been part of the WENC discussion from Day-1. If you have not seen or read the WENC recommendation regarding the HIT Zoning and Standards package, I have included them below:

**WENC Recommendations for HIT Zoning and Standards Package**

- 1. Lower the density levels by merging UR-2 into UR-1. UR-2 uses a misguided view of access to justify mid-level density in our neighborhoods, something that was soundly rejected in Phase 1.**
- 2. Limit density in a merged UR-1 and UR-2 to no more than the state-mandated 4 housing units plus 2 affordable bonus units.**
- 3. Limit density in UR-3 to the standards that you have labeled as UR-2.**
- 4. Retain deep and wide setbacks and 25' height restrictions that were used for residential zoning before Home in Tacoma.**
- 5. Require design standards in terms of scale and architectural style to ensure new buildings are compatible with neighborhood patterns.**
- 6. Strengthen tree canopy requirements to ensure that developers don't opt out.**
- 7. Require at least one designated parking space per housing unit.**
- 8. Ban shipping containers for housing and residential storage.**
- 9. Require developers to pay all impact fees.**

I agree with the WENC recommendations with one exception: Developments should have a minimum of two (2) parking spaces per housing unit. Today, young people share apartments, have more than one motor vehicle, work more "gig" jobs rather than "9-5" jobs, and travel from job-to-job in one a workday more than ever before. Invariably, each building has at least two, and sometimes more, vehicles per housing unit. One parking space per housing unit is insufficient and developments should not be approved without a minimum of two "on-site" parking spaces per housing unit.

These are my recommendations for the HIT Zoning and Standards package.

Mike Elliott  
3301 N. Shirley Street  
Tacoma 98407

**From:** Michael Lafreniere <info@historictacoma.org>  
**Sent:** Monday, September 23, 2024 4:17 PM  
**To:** City Clerk's Office  
**Subject:** Public Hearing Comment - RES 41495 - Home In Tacoma Zoning and Standards package  
**Attachments:** HIT2 Letter to City Council.pdf

On behalf of Historic Tacoma's board of directors, I am forwarding the attached written comment for the public hearing on Resolution 41495 - Home In Tacoma Zoning and Standards package. This written comment is submitted for the record.

Thank you.

Michael Lafreniere  
Communications Director  
(253) 228-0925



[www.HistoricTacoma.org](http://www.HistoricTacoma.org)  
[www.facebook.com/HistoricTacoma](https://www.facebook.com/HistoricTacoma)



September 23, 2024

EDUCATION.  
ADVOCACY.  
PRESERVATION.

[www.HistoricTacoma.org](http://www.HistoricTacoma.org)

**Board of Directors**

- Bill Baarsma
- Jennifer Baersten
- Kathleen Brooker
- Steve Dunkelberger
- Ross Griffith
- Marshall McClintock
- Marc McDonald

**Staff**

Michael Lafreniere,  
Outreach & Communications  
Director

 on Facebook  
@HistoricTacoma

 on Threads  
@HistoricTacoma

 on Instagram  
@HistoricTacoma

 [info@historictacoma.org](mailto:info@historictacoma.org)

Mailing Address  
PO Box 7664  
Tacoma, WA 98417-0664

Mayor Woodards and City Council Members  
c/o Tacoma City Clerk  
733 Market Street, Room 11  
Tacoma, WA 98402

RE: Resolution 41495 - Home In Tacoma Zoning and Standards package

Dear Mayor Woodards and City Council Members:

Historic Tacoma submits these comments for consideration regarding Resolution 41495 concerning the Home In Tacoma Zoning and Standards package (HIT2). We support the City’s goals to increase housing density, enable more housing, and make Tacoma a more livable city for all, but have serious concerns about the current proposal. While we submit the following suggestions to improve HIT2 by mitigating potential negative effects and helping prevent unintended consequences, these comments should be categorized as being in opposition to the current HIT2 proposal. Please include these comments as part of the City’s record on this matter.

**Balance the Scope of Changes with More Responsible Implementation**

The current proposal is a substantial increase in density allowances from what was proposed in the 2021 *One Tacoma: Comprehensive Plan* and in Home In Tacoma Phase 1 as well as much more than required by state regulation. While we support increasing housing density, this proposal is not accompanied by adequate controls that will ensure that our community benefits the most from these changes rather than developers. Instead of taking a more moderate approach to the amount of permitted density (which would allow for a phased process and later adjustments), this proposal is prioritizing opportunities for developers to build more market-rate, luxury apartments rather than prioritizing thoughtful, intentional community planning and truly affordable housing.

To address this, the City should either reduce the permitted density overall to what is required by the state (4 units per parcel) for a more gradual approach, or implement much stronger controls that focus on fulfilling the goals outlined in the 2021 *Comprehensive Plan* to promote “appropriate design, locational and other standards, where they can fit harmoniously with the overall scale of the neighborhood” and “[allow] the continuation of the general scale and characteristics of Tacoma’s residential area while accommodating quality, context-sensitive urban infill through design standards, project review procedures, and zoning requirements” (*One Tacoma: Comprehensive Plan*, Chapter 2, Urban Form).

During the implementation of HIT 1 in 2021, the issues of design standards and review were constant topics. Tacomans were assured there would be careful design review to ensure compatibility of new infill with existing neighborhoods. For example, Policy DD-4.14(d) of the *Comprehensive Plan* requires that infill be “...consistent with massing and scale of neighboring structures and uses compatible design language.” HIT2, however, proposes a “one size fits all” solution. Then we were assured that the infill buildings in Mixed-Use Centers

would never be allowed in areas currently zoned R1, R2, and R3. However, HIT2 encourages stacked slot buildings, stacked Reggie duplexes, deep townhouses, or 6- and 8-packs. Assessing massing, scale, and setbacks of adjacent homes or neighborhood patterns is prohibited, rendering any “form-based” zoning that responds to the priorities laid out in the 2021 Comprehensive Plan moot. In fact, HIT2 only proposes wide-scale traditional zoning that specifies maximum allowable heights and minimum setbacks. As proposed, public accountability and transparency along with neighborhood and community participation are significantly reduced.

### **Mitigate Pressure Concentrated in Older Areas of the City**

Because the North Slope and Wedge Historic Districts are City-designated, there will be design reviews for these neighborhoods to help thoughtfully manage the changes that HIT2 will bring, but permitting UR3 in these historic areas presents a significant change that could negatively affect their historic character. As well, many other historic areas of the city will experience significant development pressures—while not designated, other older neighborhoods are critical to Tacoma’s character and efforts should be made to encourage their retention. To help prevent the loss of historic buildings and the character of Tacoma in historic areas, the City should:

- reduce currently planned UR3 areas in designated residential historic districts to UR2;
- require the deconstruction (rather than demolition) of buildings of a certain age by developing a citywide deconstruction ordinance and program; and
- dedicate more staff to the City of Tacoma Historic Preservation Office to support the establishment of more designated historic districts to better manage development pressure in these areas.

### **Improvements to the Retention Bonus**

Historic Tacoma appreciates the effort to incentivize the reuse of existing buildings; retaining buildings will help preserve non-designated historic structures and prevent the loss of embodied carbon. However, we have concerns about the potentially unintended consequences of developers adhering to the “letter of the law”—reusing the minimum amount of building required—but not the “spirit”—implementing changes to a building that are compatible with both the existing building and the neighborhood’s character. We recommend the City:

- for building retention, change the “50% of the building footprint” requirement to “50% of overall square footage” and add a requirement to preserve 50% of the roofline/roof design of the structure to help with massing and scale compatibility and prevent “facadism;”
- require a transparent compatibility-based design review process that allows for public comment to ensure changes are in line with the existing character of the property and its surroundings; and
- require deconstruction (rather than demolition) for any properties receiving either the affordability or retention bonuses.

### **Ensure Enforcement of Bonuses**

The bonuses provided in HIT2 are well intended but will only have the desired positive effects if the City is willing to dedicate resources to ensuring they are enforced. This pertains especially to items that may change after a project is completed, such as affordability units and the survival of trees. To ensure that the bonuses are not being abused, the City will need to dedicate additional staff in the appropriate departments to help educate the public and ensure compliance over time.

## **Reform the Approach to Trees**

Trees and green spaces are an important component of urban design and HIT2 does not go far enough to require developers to contribute to the city's tree canopy and green spaces. Buildings should be designed in coordination with robust trees and green spaces, instead of the trees and green spaces being minimized and incidental to the building design. There is no requirement to keep mature trees, the size of the required setbacks are not sufficient for large trees, and there are no requirements for maintenance and preservation of planted trees. The approach to trees and green spaces needs to be reworked and the City should:

- increase setback requirements to make provide room for larger tree species;
- increase proposed lot percentages of tree canopy in all categories by 5%; and
- require the preservation of mature trees and the maintenance of planted trees for a minimum of two years (including replanting if necessary).

## **More Transparency about Wealthy Neighborhoods**

Tacoma's Historic Districts comprise less than 1% of the land in the city, yet View Sensitive Districts (VSDs), which encompass Tacoma's wealthiest and least intensely developed neighborhoods, cover some 12% of the city and have building heights restricted to 20 or 25 feet. Additionally, there are restrictive covenants and Homeowner Associations (HOAs) in other wealthy neighborhoods that will ensure Home In Tacoma will have the least effect on the wealthiest neighborhoods. To be more transparent about this fundamental inequity in HIT2, the City should:

- identify how much of the city is restricted by covenants or HOAs so the amount of area is clearly understood;
- represent the VSDs, restricted covenants, and HOAs on HIT2 accurately on maps and in materials available to the public; and
- reduce the height limit in UR1 to a maximum of 25 feet to make the impact of HIT2 more consistent across neighborhoods.

Thank you for the opportunity to comment, please do not hesitate to reach out to Historic Tacoma with any questions.

Sincerely,



Jennifer Baersten, President  
Historic Tacoma Board of Directors

**From:** Zoning  
**Sent:** Monday, September 23, 2024 4:21 PM  
**To:** City Clerk's Office  
**Subject:** FW: it could have happened to me...

**Importance:** High

Good afternoon, City Clerk's Office,

Zoning received the email below. It could be written comment for Home in Tacoma. Honestly, we are not sure. We reached out to Ms. Kent-Napier for clarification but have yet to receive a response.

We want to ensure that if Ms. Kent-Napier's email is to submit written comment for Home in Tacoma, her email does not get overlooked/missed.

Respectfully,

Arielle Flesher (she/her)  
Associate Planner  
City of Tacoma  
Planning & Development Services  
747 Market Street, RM. 345  
Tacoma, WA 98402  
D: (253) 591-5298  
C: (253) 732-6010  
[aflesher@cityoftacoma.org](mailto:aflesher@cityoftacoma.org)

---

**From:** Zqueen Cajunfoods <[cajunfoodsqueen@gmail.com](mailto:cajunfoodsqueen@gmail.com)>  
**Sent:** Monday, September 23, 2024 12:53 PM  
**To:** Haycock, Kristina <[KHaycock@cityoftacoma.org](mailto:KHaycock@cityoftacoma.org)>  
**Subject:** it could have happened to me...

Felizardo and Averitt acting out in a violent manner. The damage they caused is irreconcilable to Zydeco Queen's Plans at 1902 MLK Jr. Way. It was the most difficult situation that occurred at the Mini-Mall. 19th and MLK Jr. Way has 250,000 vehicles each day moving through the Hilltop of Tacoma. The facts are engraved in the minds of my 2286 customers waiting for me to open my commissary kitchen. This raw and authentic foods are prepared onsite and outside training individuals to become entrepreneurs and generate income. Most of the cooked meals go to unsheltered citizens and the Hardest to service population. Many people work jobs under the federal poverty income level. Most citizens who come in contact with Zydeco Queen Commissary Kitchen support the growth of homestyle cooked meals at walking distance of a park. Seniors, young unsheltered adults and parents seeking well prepared veggies, and other healthy meals tips. Yet, Zydeco Queen focuses on the housing crisis in Pierce county during the winter seasonal down time of construction. Now Looking at the entire region X to generate capital for housing the second real opportunity for people historically missed or left behind in the educational systems, Housing and Urban Development system and employment systems. The oversights are on the path of correcting. Yet the 360 million people in the United State of America weigh on less than 30% of successful solutions. The 42 million dollars budget is what we project to be our five year projection for successfully housing at 8.5 million per year. The labor and material costs are increasing 20% - 50% each year. The confirmation of building plans change and the budget figures are flatlining as we communicate. As the Working invisible unsheltered with no ownership in their dreams we are planning to establish a pipeline of ownership during the shelter plans. We have worked with a team generating funding since 1995. We feel strongly about the grant procedures being 10% of our 42 million budget. We set goals for individuals to generate 100% of their living in place goals. We are establishing a plan for each participant to raise \$100,000 per year toward the living expenses. We identify our training as "Moving up to help others". In this unsolicited request to meet us where we are operating.

Respectfully Submitted  
Lavada Kent-Napier

**From:** Alisha Rodenbach <[alisha.rodenbach@gmail.com](mailto:alisha.rodenbach@gmail.com)>  
**Sent:** Monday, September 23, 2024 4:31 PM  
**To:** City Clerk's Office  
**Subject:** Notice of Public Hearing Comments on Home in Tacoma Zoning & Standards Package

Dear City Council:

While I support housing affordability, I am concerned about any plan that allows for broad based rezoning as compared to something that is more focused on the hillside area of Tacoma.

The broad-based rezoning will lead to overcrowding of the land that the residential homes are currently built on, it would lead to blocking beautiful city views, and traffic congestion would significantly increase (especially since the lights are not timed or sensorred). A preferred rezoning plan would be to focus on the hillside area of Tacoma, as that area is desolate and is ripe for development. The hillside area is near the light rail and the freeway so residents would benefit from the increased accessibility of transportation, and the City would benefit from increased population density as it would stimulate the business economy in Downtown Tacoma (i.e. restaurants, cultural centers, shops etc.).

In conclusion, I would support of a more restrictive rezoning of Tacoma that focuses on the undeveloped Hillside of Tacoma.

--

Thank you,

**Alisha N.Y. Rodenbach**  
Attorney at Law  
[Alisha.Rodenbach@gmail.com](mailto:Alisha.Rodenbach@gmail.com)



**From:** Sue Leusner <susanleusner@gmail.com>  
**Sent:** Monday, September 23, 2024 4:33 PM  
**To:** City Clerk's Office  
**Subject:** HIT

Hello, I live in the West Slope neighborhood and have been following HIT meetings for quite a while. The one thing I have noticed in public comment (oral and email) is the overwhelmingly large number of Tacoma residents who are OPPOSED to this plan in its entirety. Are you going to listen?

Personally I am opposed to anything beyond what HB1110 allows for. I don't understand why we need to exceed those requirements. Does it make the City Council feel virtuous?

Single-family housing is not something that should be denigrated, rather it should be a goal for all. I don't feel ashamed that my husband spent 13 years of his life getting the education and credentials that allow us to have a single-family home in a nice neighborhood.

Why are we expecting tens of thousands of people to move here? Is there some very large business/industry that will bring in an influx of people that large? The population hasn't even grown over 1% over the last 4 years. So who really needs all of this housing?

What do people do who can't afford to live in Seattle? They live on the periphery. You are planning for a demand that is nonexistent and at the same time disruptive to the existing taxpayers in Tacoma.

I would love to see the City's effort be focused on things that are agreeable to, and that positively impact, everyone--helping our drug-addicted citizens get treatment and get off the street, making our city safer, cleaning up the gobs of trash that litter our roads and highways. That's something I can get behind. Home in Tacoma? Not so much.

Regards,  
Sue Leusner  
902 S Aurora Ave

**From:** Cynthia Crose <cynthia\_home@yahoo.com>  
**Sent:** Monday, September 23, 2024 4:34 PM  
**To:** City Clerk's Office  
**Subject:** Home In Tacoma Comments

My name is Cynthia Crose, owner of 1720 N Cascade in Tacoma.

I am against the Home In Tacoma Zoning and Standards Package for the following reasons:

- 1) There is no provision to fund upgrades to the utilities in support of multi-family dwellings to be built on previously single-family zoned lots.
- 2) There is insufficient protection for the existing tree canopy..
- 3) There is insufficient street parking to support multi-family dwellings in built in previously single-family zoned neighborhoods.
- 4) There is insufficient protection to match the look, feel, and quality of the historic neighborhoods, when the Urban Residential Zone is put in place.
- 5) This proposal is unlikely to relieve the homelessness problem in Tacoma.

Thank you for registering my opinion.

Cynthia Crose  
Tacoma Resident

**From:** Janay Hull <janayhull@yahoo.com>  
**Sent:** Monday, September 23, 2024 4:36 PM  
**To:** City Clerk's Office  
**Subject:** Home In Tacoma Letter of Support

Members of the Tacoma City Council,

I'm writing as a resident of Tacoma to express my wholehearted support for the Home In Tacoma Initiative as presented. As a Tacoma native, and current homeowner in the Lincoln district, I cannot express the pride I feel in the City of Tacoma. Obviously, no location is perfect and one should always strive for progress and improvement but at the base of it all, Tacoma is a wonderful place to live. Unfortunately, the ability and opportunity to live comfortably in Tacoma has become less and less attainable for many residents/would be residents.

Tacoma was built as a Gritty City and takes pride in the working class, the blue collar and the everyday people. Preventing housing development, be it through cost, zoning, NIMBYs (Not In My Backyard) or politics only hurts the fabric and the backbone of our community, the working class. When supply goes down, and prices go up, the only people eliminated from the housing equation (be it renting or ownership) are the people in the working class. The housing crisis, though nation wide, is felt drastically across Washington and particularly in Tacoma. A failure to address this crisis will hurt the economic development and prosperity of the city. If we force the younger workforce to seek more affordable accommodations, the threshold to bring them back only grows. But, at what point do we stop asking our residents to forego economic opportunities and prosperity for the love of a City in the first place?

The science and data is clear, rents will drop if you add housing stock. Currently, the only major metro locations seeing rent decreases are the cities who added significantly to their housing inventory over the last three years. Bigger metro areas Austin, Phoenix and Atlanta each added at least 16,000 units over the past year, increasing their inventories by as much as 5.6% (<https://www.bloomberg.com/news/articles/2023-11-06/renters-get-a-bit-of-relief-from-surge-in-apartment-construction?sref=PC7lMsgi>). Home in Tacoma, while impactful, is only a drop in the bucket to the progress Tacoma needs to provide residents relief. As concluded in the HIT2 PC Findings and Recommendations, the Lower Zoning Home in Tacoma will create 53,620 new housing units over the next 25 years. That boils down to 2,145 units annually, which is only 13% of the estimated number of units (16,000) needed to actually move the needle for residents.

I am extremely excited to see Home in Tacoma progress after all this time, and genuinely appreciate all of thought put forth in this effort, but it is just the beginning. I hope to see a continued effort to build a Tacoma that welcomes everyone and provides opportunity, growth and financial relief for all residents.

Best,  
Janay Hull  
Homeowner, Lincoln District

[Sent from Yahoo Mail for iPhone](#)

**From:** Cathie Raine <cjrrd@hotmail.com>  
**Sent:** Monday, September 23, 2024 4:08 PM  
**To:** City Clerk's Office  
**Subject:** 'HOME IN TACOMA--Phase 2' Public Hearing (9/24/24) COMMENTS

The following comments and statements are being submitted for the Public Hearing (Home in Tacoma) portion of the City Council meeting on 9/24/2024.

Dear Mayor Woodards, Deputy Mayor Hines and Council Members,

I am urging you to veto/not approve to approve the 'Home in Tacoma--Phase 2' proposal (in its current form) being advanced by the Planning and Development Services Department Planners and the Planning Commission. I understand that this entire Housing re-zoning plan project has involved many hours..really years..of Planners and City officials time and resources. You all likely are tired of hearing about all the zoning changes involved too.

The common thought prevailing, I suspect, with the Council Members includes:  
"Let's get this whole thing approved and move on. We need alot more housing built ASAP".  
Also..."we need housing now; we can't worry about trees now".

However...have you taken the time to consider the following concerns (unanswered questions, studies not completed yet, issues not addressed):

1. Why is it necessary for the City of Tacoma to choose the most significant alternative for zoning changes? (Refer to the Final EIS report issued just 1 month ago). These zoning changes do go beyond what is mandated by the State as well.
2. Can't the City Planners start with these zoning changes in certain neighborhoods only...and not implement these changes at once city-wide?
3. Does this 'Home in Tacoma--Phase 2' proposal incorporate/use the 'Equity Index' to determine the best locations (within each neighborhood) for types of housing project development most appropriate to preserve tree canopy etc.? A 'housing plan'..a new zoning approach.. needs to consider the impacts of new housing on the current neighborhoods. For instance, preserving trees in a 'low equity'/low and suboptimal tree canopy' area needs to be given the same priority with housing project locations as preserving the scenic view with 'view-sensitive' neighborhood.
4. Will Pierce Transit be increasing/adding on transit services in neighborhoods with higher levels of housing concentration? It has already been acknowledged in a recent 'Downtown on the Go' article that Tacoma does not yet offer adequate 'high capacity transit' services (as defined by the State legislature) for use of the 'restricted parking allowance' (RPA) feature that would be used by housing development companies. Yet, the Planning Commission has pushed for 'extended RPA' for these housing construction plans. Why would residents want to give up car/vehicle use if they are faced with limited public transit options.
5. This 'Home in Tacoma-Phase 2' plan promotes the construction of commercial rental types of housing..due to the variety of MFTE options made available to developers now.  
We are already seeing...in that 'Tacoma Mall Extended Growth Center'..a number of smaller, older homes being torn down and then replaced with apartment buildings. These new buildings often occupy the majority of the property with possibly a few on-site parking spaces available to the tenants. Not much room left for planting trees/bushes on site..and, there's not even much of a ROW for planting trees later on. So..we are seeing 1 new apartment being located within just a few feet of a neighbor's building..crowde with cars parked on streets, incomplete sidewalks. These newer 'neighborhoods'..in this area west of the Mall are losing their tree canopy..with little hope of increasing the tree canopy as well..no land available for trees. This thought that we can wait to worry about the trees until later on..is a deeply flawed plan.
6. Why is this current 'Home in Tacoma--Phase 2' zoning plan being promoted when these several pieces of critical information are still missing:

\*impact of these zoning changes on the property values of the (pre-development) single-family houses ("units") in

neighborhoods across Tacoma. Will property values (and, property tax rates) decrease with the plan to incorporate more 'commercial' (rental units) buildings into a neighborhood of single family houses?

\*what impact will these zoning changes have on individual property and vehicle insurance rates for residents in Tacoma?

**From:** Mike Lonergan <mplonergan@nventure.com>  
**Sent:** Monday, September 23, 2024 4:47 PM  
**To:** City Clerk's Office  
**Subject:** Home in Tacoma hearing testimony

The reduced parking requirements for Home in Tacoma are a big mistake and should NOT be adopted. A visit to my neighborhood, the 3700 block of North 27th Street will show you why.

A typical residence today must have parking space for 1.5 to 2 vehicles. Anything less is wishful thinking. Reducing the requirement to one-half space per residence, as was done on my street, negatively impacts ALL residents.

Pretending that by adopting an ordinance that many or most new residents will get to work etc. by bus or bicycle is dishonest. They will not.

Someday Pierce Transit may have frequent service connecting homes to workplaces without long waits and transfers. Tacoma will always have months of cold, wet days and long, dark nights when biking is neither safe nor comfortable.

With every street parking space in my neighborhood jammed continuously, I can never again host a party or meeting in my home. Delivery and home repair trucks have nowhere to park and often block lanes of traffic. It's DANGEROUS.

PLEASE table the adoption of reduced parking requirements or remove them from Home in Tacoma. Thank you.

Mike Lonergan  
Sent from my iPhone

**From:** Deborah Cade <dlcade@comcast.net>  
**Sent:** Monday, September 23, 2024 3:09 PM  
**To:** City Clerk's Office  
**Subject:** Comments from North Slope Historic District on Home in Tacoma  
**Attachments:** Final NSHD\_HIT2\_comments\_cc\_09232024-1.pdf

Please accept these comments from the North Slope Historic District Board of Directors in opposition to the proposed Home in Tacoma program, and include in the City's record for tomorrow's public hearing. Thank you.

Deborah L. Cade  
[dlcade@comcast.net](mailto:dlcade@comcast.net)  
908 North M Street  
Tacoma, WA 98403



# North Slope Historic District

a 501 (c)(3) organization

**908 North M St.  
Tacoma WA 98403**

September 23, 2024

Tacoma City Council  
747 Market Street  
Tacoma, WA 98402

RE: Home in Tacoma Phase Two

**BOARD OF DIRECTORS**  
DEBORAH CADE, CHAIR  
HIST. PRESERVATION  
JULIE TURNER, SECRETARY  
GEOFF CORSO, TREASURER  
JUDITH MARTIN, PROGRAMS  
TOM GISKE, BEAUTIFICATION  
JOHN BUTLER, OUTREACH  
MARSHALL MCCLINTOCK  
LYNDA BEST  
ROGER JOHNSON  
HEATHER STRAUB

Dear Mayor Woodards and City Council Members:

The North Slope Historic District (NSHD) Board of Directors opposes the Home in Tacoma 2 (HiT2) proposals. These comments should be categorized as being wholly in opposition to the HiT2 proposal. Please include these comments as part of the City's record on this matter.

The NSHD is made up of exactly the housing choices described as "missing middle." The Planning Department has repeatedly used pictures of NSHD multi-family housing in its HiT1 and HiT2 promotional materials. We are also already one of the densest neighborhoods in the city (20+ units/acre) with a mix of single-family homes, duplexes, triplexes, fourplexes and larger two- and three-story multifamily buildings. Our neighborhood's development predates any zoning requirements. The historic district began in 1993, largely in response to a significant effort by developers, with Planning Department support, to buy up historic homes and apartment buildings, demolish them, and build larger, low quality, more expensive apartments. The HiT2 proposes to allow this again in our neighborhood as well as in older neighborhoods across the city.

In 2021 city council passed Amended Ordinance 28793 with many compromises and promises to assuage citizens' very legitimate concerns about needed design standards and review, compatibility with existing neighborhoods, loss of tree canopy, demolition of older, more affordable houses, failure to protect historic resources, replacement of single-family homes with expensive, tiny studio apartments, and massive tax subsidies for corporate developers to build market-rate rather than truly affordable housing to address Tacoma's actual housing crisis. The radically sweeping HiT2 throws out those compromises and subjects the city's residential neighborhoods to changes we were repeatedly assured would not be allowed, e.g. slot homes, reggie duplexes, 8-packs, and 4-5 story buildings. The proposed HiT2 violates Amended Ordinance 28793 and the Comprehensive Plan, and exceeds state legislative requirements. In short, it simply turns Tacoma's residential neighborhoods (except those protected by VSDs or HOAs) over to developers to do as they please with taxpayer subsidies.



## Specific to city-designated historic districts<sup>1</sup>

HiT2 does nothing to enhance or protect city-designated historic districts. On the contrary, the radical up-zoning envisioned by UR1, UR2, and UR3 increases development pressure on the already sensitive North Slope and Wedge city-designated historic districts in violation of Comprehensive Plan Policies UF-13.18, UF-13.29, and especially DD-13.11.d (“Avoid creating an economic incentive for demolitions within Historic Districts”). To meet Policy DD-13.11.d, the proposal should be amended to change all proposed UR2 parcels within the boundaries of the NSHD to UR1. All proposed UR3 parcels (511 N. K, 611 N. K, 922 N. 13<sup>th</sup>, the west side of N. 3<sup>rd</sup>, the east side of N. State, and both sides of N. I) should be changed to UR2. And all parcels within boundaries of the Wedge historic and conservation districts should be changed to UR1. To do otherwise leaves developers, most of whom come from outside Tacoma, with the impression that these areas are available for demolition and redevelopment.

## Affordability

HiT2 claims “affordability” is a “top priority,” but when pressed, Planning staff and city council are quick to point out that HiT2 is not addressing that crisis at all. In fact, Tacoma’s Affordability MFTE program is really using property taxpayer subsidies to build market-rate apartments with only a smattering of “affordable” units. These “affordable” units are affordable only to those with a household income of \$80,000 or more, based on Planning staff’s admission. Two people making minimum wage could not afford one. A developer who builds a 10-unit building with two barely “affordable” units gives up a little over \$17,000 in rental income over the 12-year period but walks away with over \$246,000 in taxpayer property tax subsidy. In 12 years, those “affordable” units become market rate. As a result, regressive property taxes must go up for all other property taxpayers to cover this subsidy. This does nothing to address Tacoma’s housing crisis, but simply lines the pockets of corporate developers. The city is counting on the housing market to address a problem that the housing market created in the first place.

Some claim that building more market-rate apartments “filters down” by reducing rents as well-off renters move into these new apartments from lower priced units. Recent research shows that does not happen. Increasing market-rate supply slightly moderates rent increases at the top end but does nothing for the lower end of the market as proponents of supply-side solutions had hoped. In fact, many units at the upper end remain vacant as institutional landlords, who now own more than two-thirds of all of properties with 5 to 24 units, prefer vacancies to lowering rents.<sup>2</sup>

Since Tacoma requires no mitigation fees from developers, multifamily infill that requires infrastructure upgrades (sewer, water, etc.) to handle the increased density will result in costs that must be borne by surrounding property owners with LID property tax increases. To add salt to the wound, MFTEs will ensure the developer/owner who caused the problem will NOT pay any property taxes.

## Design Standards and Design Review

As the Comprehensive Plan was rewritten in 2021 to accommodate HiT1, the issues of design standards and review were constant topics. Tacomans were assured there would be careful design review and neighborhood-based design standards to ensure compatibility with the existing neighborhoods. For example, Policy DD - 4.3

---

<sup>1</sup> Tacoma’s historic districts are often falsely accused of being exclusionary. The NSHD had Black and Asian residents from at least 1890. NSHD had no racially restrictive covenants except one small parcel (1617 N. Division). The Wedge HD had no restrictive covenants. The 1937 HOLC maps designate both areas “C – Declining” along with 90% of the rest of Tacoma. The NSHD had an area of about 100 parcels designated “D – Dangerous”.

<sup>2</sup> R. Abraham, “U.S. building more apartments than it has in decades, but not for the poor,” *Vice*, 07/13/2023.

calls for infill development that "... complements the general scale, character, neighborhood patterns, and natural landscape features of neighborhoods." Policy DD – 4.14 (d) requires that infill be "consistent with massing and scale of neighboring structures and uses compatible design language." There are other similar policies.

Public goods, especially for MFTE subsidies, should be required, not incentivized. To ensure inclusion and sustainability, full wheelchair access must be required to receive an MFTE even if not required by the building code. Similarly, the preservation of already existing large trees on parcels as requirements to meet full life-cycle green requirements should be required to receive an MFTE.

HiT2, however, proposes a "one size fits all" solution. Design standards have not been developed for different neighborhoods. Infill building types found in Mixed-Use Centers that were expressly claimed would never be allowed in currently zoned R1, R2, and R3 residential neighborhoods, such as stacked slot houses, stacked Reggie duplexes, deep townhouses or 6- and 8-packs, are now encouraged. Assessing massing and scale based on adjacent homes or neighborhood pattern is expressly forbidden, rendering such assessments moot.

HiT2 claims to provide "form-based" zoning, but it is only the traditional or Euclidian zoning that specifies maximum allowable heights and minimum setbacks. Only 5 foot side setbacks are required even for 4- and 5-story buildings. It's no exaggeration to say that the maximum allowable massing and heights in UR1, UR2, and UR3 are wholly incompatible with all of city's residential neighborhoods. This is "one size fits all" zoning and design standards.

The 2021 Comprehensive Plan update specifies numerous policies that require neighborhood compatibility design review that HiT2 completely ignores. Here is just a sample: DD-1.2, DD-1.4, DD-1.6, DD-1.7, DD-1.11, DD-4.1, DD-4.3, DD-4.6, DD-4.10, DD-4.13, DD-4.14. b, c, d, DD-4.a, DD-4.d, DD-5.14, DD-9.1, DD-13.12.

"Design review" now eliminates any public input and merely assesses if the proposed infill fits the building maximums. This contradicts Comprehensive Plan Goal DD-15 that specifically calls for "neighborhood-level planning initiatives" to be "guided by community involvement." HiT2 has been developed without the involvement of specific neighborhoods. Instead, it has been developed wholly with developer-dominated advisory groups in non-public meetings. Public input and transparency are eliminated. Neighborhood or community participation is neutralized. HiT2 re-establishes the worst aspects of 1960s "urban renewal." Corporate developers are now allowed to do whatever they want, and all public goods are reduced to being "incentivized."

### **Tree canopy**

HiT2's landscaping code is totally inadequate and will only ensure the loss of more of Tacoma's already meager tree canopy while giving developers huge tax subsidies for building more market-rate housing we don't need. Tree retention should not be "incentivized" but rather required. Established trees on private property, which are primarily found in residential neighborhoods and especially in historic districts and other older neighborhoods, are absolutely critical to maintaining Tacoma's meager tree canopy. This is especially true since trees take 20-30 years to gain shading canopy and the ability to capture CO<sub>2</sub>.

At least 30 percent tree cover should be required for UR1, UR2 and UR3 zones and should be required for any MFTE. Similarly, trees that are 4 inches or more diameter at breast height (DBH) must be preserved on any HiT2 infill parcel for any MFTE. Moreover, MFTE programs must require proper care as well as replacement of comparable sized trees for those that die or become diseased. Any violation should result in immediate revocation of the MFTE for the parcel, banning receiving any future MFTEs for 10 years and steep fines.

Additionally, the “fee in lieu” program is unworkable since the city doesn’t have enough public land to accommodate replacement trees, and in any case, they wouldn’t be in neighborhoods where they are needed. The overbuilding allowed by HiT2 ensures that only small trees that provide little if any canopy can be planted. Only small trees (e.g. plums, hawthorns, redbuds) could thrive in the small spaces allowed for trees. Tiny setbacks ensure that trees will be mashed up against buildings, which is unhealthy for trees and unsafe for the building. No “green space” as opposed to “open space” is required for play areas or vegetable gardens. Packing more housing units on small parcels will ensure the creation of even more “heat islands” in Tacoma’s residential neighborhoods, a major health hazard. This must not be allowed.

### **View Sensitive Districts (VSD) and Home-Owner Association (HOA) restrictions**

We are concerned that the negative impacts of HiT2 will not be equitably shared across Tacoma. VSDs cover 12 percent of Tacoma’s land (virtually all of Northeast Tacoma) and cover most of Tacoma’s wealthiest neighborhoods with the largest parcels. VSDs limit building heights to 25 feet and sometime 20 feet, ensuring that no 3-story apartment buildings allowed by UR1, UR2, and UR3 will be built there. When questioned about this, Planning staff replied that the 25 feet height limit allowed for plenty of “missing middle” infill. If so, then reduce the maximum height of UR1 to 25 feet. Why should the rest of Tacoma bear the extra burden that HiT2 imposes?

Additionally, another estimated 12 percent of the city is covered by HOAs that by deed (Covenants, Conditions and Restrictions) limit development to single family housing as well as defining building heights and setbacks. These covenants are contractual obligations and cannot be altered by legislation or zoning changes. Again, these wealthy neighborhoods will be exempt from the negative impacts of HiT2 that Tacoma’s other neighborhoods must bear. This is inequitable in the extreme.

### **Housing retention and deconstruction**

The greenest building is an existing building. Tacoma was completely built out by 1940. Most of Tacoma’s housing stock was made by skilled local craftsmen out of old-growth wood that holds a huge amount of embedded carbon. Demolishing them and carting the remains to landfill is a sustainability and environmental disaster. Every effort should be made to retain and reuse existing buildings, and when that is not possible, they should be deconstructed so that materials can be reused or recycled.

The proposed building retention “bonus” is another misguided attempt to “incentivize” a needed public good that should be required. Moreover, it is structured so that it will ensure more demolition. It requires the retention of only 50 percent of the building footprint, which still allows a huge amount of demolition. Moreover, it only requires keeping the first 10 foot depth of the front façade unchanged, which promotes “facadism” in which a historic façade is essentially pasted onto a new building. Imagine a large three-story building with one-story Cape Cod entry. The “bonus” requires that new additions be “harmonious with” and “complementary to” the existing building and “incorporate distinguishing ... design features” of the existing building. However, it doesn’t require similar materiality, massing, or height to achieve that and nor does it specify what criteria will determine whether what’s proposed meets these requirements. Cladding, windows, and doors can all be changed, so what is actually retained? The proposed housing retention bonus simply allows too much change and not enough retention. While many of these issues could be addressed, this “bonus” will pale next to other bonuses that allow demolition.

To promote building retention and reuse and limit demolition, what is needed is a deconstruction requirement like that implemented in Portland, Beaverton, San Antonio, Milwaukee, Vancouver, and Paris. This would require the deconstruction rather than demolition of any building that was built before 1950 by a certified deconstruction contractor. This would salvage valuable building materials for reuse, reduce carbon emissions

associated with demolition, and greatly reduce the amount of demolition waste in landfills. Adding a strong deconstruction element to HiT2 will help retain existing, already-affordable houses as well as address sustainability and climate change.

### **“Bonuses” for breaking up homes into apartments**

Not only does the “preservation bonus” not serve a good preservation or sustainability purpose, it also puts individual and family home buyers in competition with corporate buyers who will always be able to outbid them. This illustrates what HiT2 will ultimately accomplish: building new, more expensive, small rental housing for a transient residential population, and forcing families and longer-term residents out of Tacoma.

We mentioned earlier that prior to NSHD’s being listed as a historic neighborhood, the city was encouraging the demolition of older homes to be replaced with apartment buildings, as well as the breaking up of larger homes into apartments. Since the historic district listing, many of our poorly broken-up homes have been restored and the damage repaired. A good example is 504 North L Street, which was used as a rooming house and was a location of regular criminal activity. That home has been nicely restored and is now a four-plex. After the significant investment in time and money that has been made in this neighborhood, HiT2 now seeks to undo that work by encouraging and rewarding the same destructive activity that was occurring back in the 1970s and 1980s.

There are so many ways to incentivize the creation of new housing in Tacoma that would provide not only needed housing, but also needed home ownership opportunities. It’s unfortunate that HiT2 doesn’t include any of them. If the City was serious about providing more actual housing and home ownership opportunities, it would not be handing over all decision-making responsibility to corporate developers and property investors. Rather than allowing corporate developers to destroy existing housing, the city could identify areas where new buildings could be built, including lots that could be subdivided. If the City was serious about affordable housing, it would protect older housing that is more affordable than new construction and focus on using tax subsidies to build actual public housing. The only beneficiaries of HiT2 program are the corporate developers and investors, not the people of Tacoma.

Please reject this HiT2 proposal.

Sincerely,

/s/

Deborah L. Cade  
Chair, North Slope Historic District Board of Directors

**From:** Bernard Bates <bates@pugetsound.edu>  
**Sent:** Monday, September 23, 2024 4:21 PM  
**To:** City Clerk's Office  
**Subject:** The Home in Tacoma Zoning Changes

Attention City Clerk: Please distribute the following to all Council Members.

*Please do not pass the **Home in Tacoma** zoning changes. Instead, manage the zoning changes already made by **House Bill 1110 passed by the Washington Legislature in 2023.***

Sincerely,  
Bernard and Jillian Bates  
Tacoma North Slope Historic District  
819 N J Street  
Tacoma, WA 98403  
(253)651-0165

**From:** Tom Giske <tgiske@gmail.com>  
**Sent:** Monday, September 23, 2024 4:09 PM  
**To:** City Clerk's Office  
**Subject:** Comments Regarding Home in Tacoma Phase 2 Hearing  
**Attachments:** September 23 2024 F public comments TUFF.pdf; Tacoma Tree Canopy Petition.pdf

Please see attached *Cover Letter* and *Attachment* from Tacoma Urban Forest Friends as comments regarding Home in Tacoma Phase 2:

Tom Giske  
(425) 301-5925 (Voice or Text)



September 23, 2024

Respectfully to Mayor Woodards and Tacoma City Council,

**"Petition to the City Council of Tacoma to Protect and Extend Our Tree Canopy" from the Tacoma Urban Forest Friends (TUFF).**

At today's meeting, TUFF members would like to submit our updated 2,454 signatures from voters and/or citizens of Tacoma and Pierce County who are concerned about the continued loss of Tacoma's tree canopy and therefore request that the City of Tacoma take specific actions to achieve their goal of 30% canopy by 2030. TUFF will continue to update the Council regarding this petition.

- Private Property and Public Right of Ways

The December 2023 passage of the Tree Ordinance TMC 9.20 was the first step to help protect and expand our public right-of-way trees. And now with Home in Tacoma's Landscaping Code, we have the opportunity to protect and expand our tree canopy on private land. It's essential that we take *both* of these important steps so we will be on the way to create a thriving urban forest that will provide a healthy and sustainable future for generations to come.

- Time for Action

We strongly recommend that our city uses their 2019 Urban Forest Management Plan Phase 2: Action Plan, to serve as a roadmap that will lead to the protection and extension of our tree canopy on both public and private property. Yet, in order to implement this Plan, decisive City leadership will be needed to designate adequate annual funding.

- Climate change is occurring swiftly.

Tacoma leadership has the responsibility to protect our mature trees while planting for the future of our children, and theirs. Preserving the Planning Commissions Landscaping Code is essential. Our health, and nature's, is dependent on whether this council will demonstrate a new vision to aggressively tend to our urban forest's future.

Sincerely,

Georgette Reuter, Leader

Tacoma Urban Forest Friends (TUFF)

Attachment: Petition to the City Council of Tacoma  
To Preserve and Extend Our Tree Canopy



**Petition to the City Council of Tacoma  
To Preserve and Extend Our Tree Canopy**

**Submitted September 23, 2024**

**For review in support of the Landscape Code  
to be included in  
Home in Tacoma Phase 2**

Tacoma Urban Forest Friends (TUFF)  
Georgette Reuter, Leader





## Reforestation Tacoma Must Be Our Highest Priority!

This petition continues to be active and remains available either on paper forms or online at [Restore Tacoma's Tree Canopy](#). Currently it is approaching 2,500 signatures, and our experience is that at least 80% of those approached sign their name. We have carefully reviewed every signature and eliminated all known duplicates. We present the names in alphabetical sequence so you can personally confirm the absence of duplicates – you will find a few duplicate names, but our review suggests they are different people. This alphabetical listing also gives you the opportunity to look for names of those who have or have not yet signed.

This is a grass roots effort without any professional assistance or online software such as Change.org. We are just concerned citizens who believe Tacoma must reforest its streets to preserve the good health of our people, the natural health of our environment, the cleanup of Commencement Bay, the future of Puget Sound, the desirability of our downtown, and the success of any programs to increase the density of our housing. To live without trees is to live with unnecessary risks to our personal health and the incentive for others to share the long-term benefits of living in the Pacific Northwest.

The original signatures on these petitions are preserved on either paper forms or in a protected online file. Note that the specific paper form and line number for each such signature is identified on the attached listing, making it easy to find the original signature for any of the names listed. These original signatures are available for review by appropriate authorities of the City. You may contact Tom Giske at [tgiske@gmail.com](mailto:tgiske@gmail.com) or (425) 301-5925 (Either voice or Text) to gain access, or to ask any questions regarding the petitions or the process.

Tacoma Urban Forest Friends (TUFF)  
Advocates for Reforestation Tacoma



# Petition to the City Council of Tacoma To Protect and Extend Our Tree Canopy

*At 20%, Tacoma has the smallest tree canopy of any city in the Puget Sound area! The City promised us in 2009 and again in 2019 to increase our tree canopy to 30% by 2030. We are not on track and no increase has been achieved. This is now urgent as new development threatens our existing 20% tree canopy. We ask you to honor the City's commitment and deliver the tree canopy we need.*

## **Why?** *Our trees are our most important asset to:*

- *Clean our air and produce the oxygen we need to breathe.*
- *Help offset rising temperatures in our city.*
- *Reduce storm water runoff while limiting soil erosion and pollution in our waterways.*
- *Improve the public health of our communities.*
- *Add beauty to our neighborhoods while muffling city noise.*
- *Offer food, protection, and homes for wildlife.*
- *Bring cooling shade to our buildings in the summer and buffer against cold weather in the winter.*

**We the undersigned registered voters and/or residents of Tacoma and Pierce County, who are concerned about the loss of tree canopy, respectfully request the City Council to take the following actions:**

- ✓ Pass the Tree Ordinance TMC 9.20 proposed by our Urban Forestry Department. **[Achieved, Passed 12/12/2023]**
1. Fully fund and implement the planting of enough new trees (with appropriate maintenance) to achieve the City's goal of 30% canopy by 2030.
  2. Integrate the protection of established trees and the planting of new trees based on a 30% minimum requirement for canopy coverage in all zones for new construction and/or remodeling into the Home in Tacoma Phase 2 revisions.
  3. Fund the City of Tacoma's Urban Forestry Department with adequate staffing to protect and prune all public trees, including trees in the Right-of-Way.
  4. Create the volunteer Urban Forest Commission called for in the city-adopted Urban Forest Management Plan.
  5. Create a Heritage Tree Program that designates and protects trees of unique value to the neighborhoods where they reside [Initiated in TMC 9.20, but protection must be added].
  6. Educate developers and tree service companies to understand how important trees are to the future of our city and encourage them to seek ways to preserve established trees.

<u>Date</u>	<u>Full Name (Printed)</u>	<u>Signature</u>	<u>Email Address (Will not be shared)</u>	<u>Keep Me Informed (✓)</u>
01				<input type="checkbox"/>
02				<input type="checkbox"/>
03				<input type="checkbox"/>
04				<input type="checkbox"/>
05				<input type="checkbox"/>
06				<input type="checkbox"/>
07				<input type="checkbox"/>
08				<input type="checkbox"/>
09				<input type="checkbox"/>
10				<input type="checkbox"/>

SAMPLE

# Reforestation Tacoma Must Be Our Highest Priority



## Petition to the City Council of Tacoma To Preserve and Extend Our Tree Canopy



At 20%, Tacoma has the smallest tree canopy of any city in the Puget Sound area! You promised us in 2009 and again in 2019 to increase our tree canopy to 30% by 2030. We are not on track and no increase has been achieved. This is now urgent as new development threatens our existing 20% tree canopy. We respectfully ask you to honor your commitment and deliver what you promised.

**Why? Our trees are our most important asset to:**

- Clean our air and produce the oxygen we need to breath
- Help offset rising temperatures in our city.
- Reduce storm water runoff while limiting soil erosion and pollution in our waterways.
- Improve the public health of our communities.
- Add beauty to our neighborhoods while muffling city noise.
- Offer food, protection, and homes for wildlife.
- Bring cooling shade to our buildings in the summer and buffer against cold weather in the winter.

**We the undersigned registered voters and/or residents of Pierce County respectfully request you to take the following actions:**

- ✓ Pass the Tree Ordinance TMC 9.20 currently proposed by your Urban Forestry Department. **(Accomplished)**
2. Fully fund and implement the planting of enough new trees (with appropriate maintenance) to achieve the City's goal of 30% canopy by 2030.
3. Integrate the protection of established trees and the planting of new trees based on a standard minimum requirement for canopy coverage into Home in Tacoma revisions.
4. Fund the City of Tacoma's Urban Forestry Program with adequate staffing (including a Landscape Architect).
5. Create the volunteer Urban Forest Commission called for in the city-adopted Urban Forest Management Plan.
6. Create a Heritage Tree program that designates and protects trees of unique value to the neighborhoods where they reside.
7. Educate residents, tree service companies and developers to understand how important trees are to the future of our city and encourage them to preserve established trees.

<u>Voter/Resident</u>	<u>ID</u>	<u>Page</u>	<u>Line</u>	<u>Date</u>
Kenneth S. Abels	1	607	10	3-Aug
Megan Achille	2	0		25-Nov
Kina Ackerman	3	609	3	3-Aug
Doris Acosta	4	0		28-Nov
F. Acosta	5	702	5	3-Aug
Kay Acosta	6	702	6	3-Aug
John Adams	7	0		2-Jan
Megan Adams	8	115	8	23-Sep
Shera Adams	9	115	9	23-Sep
J. Admiral	10	621	2	3-Aug
Laurie Arnold	11	122	3	23-Sep
Annette Ruth Agee	12	0		1-Jul
Michelle Agne	13	0		1-Jul

# Reforestation Tacoma Must Be Our Highest Priority

<u>Voter/Resident</u>	<u>ID</u>	<u>Page</u>	<u>Line</u>	<u>Date</u>
Tooa Ahdar	14	334	4	21-Oct
Elizabeth Ahlstrom	15	164	1	23-Sep
Jennifer Ahuas	16	211	8	18-Nov
Jacquelyn Aiello	17	703	5	3-Aug
Jamil Akram	18	323	1	21-Oct
Sarah Albert	19	384	1	29-Oct
Natasha Alciso	20	610	2	3-Aug
John C. Alessio	21	326	1	29-Oct
Hayes Alexack	22	T330	2	7-Sep
Mira Alexander	23	625	6	3-Aug
Salexia Alexander	24	191	6	18-Nov
Steve Algieri	25	0		27-Aug
Kay Allgood	26	657	9	7-Sep
Barb Alling	27	41	1	20-Oct
Kristen Allott	28	0		5-Jun
Dena Alo-Colbeck	29	0		22-Jul
Kelsey Alshememry	30	0		26-Jun
Hunter Alvis	31	167	5	14-Oct
Amy Andersen	32	82	7	10-Oct
Erin Andersen	33	0		30-Nov
Deb Anderson	34	123	5	23-Sep
Debra Houghton Anderson	35	0		2-Dec
James Darrell Anderson	36	0		30-Dec
Judith S. Anderson	37	0		13-Dec
Kenneth Anderson	38	192	7	28-Sep

# Reforestation Tacoma Must Be Our Highest Priority

<u>Voter/Resident</u>	<u>ID</u>	<u>Page</u>	<u>Line</u>	<u>Date</u>
Robert Anderson	39	222	10	3-Dec
Doug Andreassen	40	211	10	31-Oct
Julie Andrejewski	41	326	2	29-Oct
Miguel Andreve	42	0		12-Jun
Arielle Andrews	43	312	10	23-Oct
Gerald Andrews	44	120	1	27-Sep
Fredrick J. Angelo	46	610	9	3-Aug
Shelley Angelo	47	610	8	3-Aug
Lauren Angotti	48	0		11-Jan
Carlos Anicama	49	0		22-Jul
Gene L. Ankli	50	801	1	3-Aug
Barbara Ann	51	0		3-May
Aowen Annbjorg	52	0		27-Nov
Chris Apostolos	53	0		30-Nov
Laurence Applen	54	0		23-Jul
Eric Ard	55	0		15-Nov
iLeana Areiza	56	0		24-Jun
Kaela Arellano	57	0		23-Jul
Sean Arent	58	0		29-Nov
Angelica Arias	59	0		28-Nov
Susan Armbruster	60	627	4	3-Aug
Marci Armitage	61	0		26-Nov
Angela Arms	62	620	6	3-Aug
Angelita Arms	63	0		6-Nov
Paul Arms	64	0		6-Nov

# Reforestation Tacoma Must Be Our Highest Priority

<u>Voter/Resident</u>	<u>ID</u>	<u>Page</u>	<u>Line</u>	<u>Date</u>
Dan Armstrong	65	337	4	21-Oct
Veronica Armstrong	66	334	2	21-Oct
Katherine Arnold	67	0		23-Jul
Oneida Arnold	68	0		1-Dec
Nicole Arruda	69	0		29-Nov
Darelyn Arter	70	152	7	21-Oct
Laura Ashley	71	0		29-Dec
Efferts Ashton	72	628	4	3-Aug
Mark Atkins	73	0		8-Jun
John Atwill	74	0		29-Nov
Nancy Atwood	75	0		14-Nov
Anthony Augustenborg	76	0		14-Nov
Brittney Augustenborg	77	0		14-Nov
Lyddie Austin	78	0		15-Dec
Austin	79	0		22-Jul
Alex Avanto	80	0		29-Nov
Gigi Averitt	81	0		3-Jun
John Avery	82	167	9	14-Oct
John Avery	83	0	0	20-Sep
Rose Ayala	84	210	8	26-Oct
Stephanie Kennedy Ayer	85	0		21-Nov
Megumi Azekawa	86	0		8-Jun
William H. Baarsma	87	165	3	23-Sep
Sharon E. Babcock	88	0		30-Nov
Conrad Babich	89	167	4	23-Sep

# Reforestation Tacoma Must Be Our Highest Priority

<u>Voter/Resident</u>	<u>ID</u>	<u>Page</u>	<u>Line</u>	<u>Date</u>
Mailo Baca	90	0		17-Nov
Mark Backus	91	0		6-Jun
KC Bacon	92	41	3	20-Sep
Kevin Bacon	93	0		2-Jun
DeAnne Baer	94	0		22-Jul
Samantha Bagley	95	T328	8	7-Sep
Tom Baier	96	0	0	20-Sep
Jacqueline Bailie	97	0		1-Jul
Sarah Bailie	98	0		1-Jul
Katie Baird	99	0		2-Dec
Carol J. Baker	100	0		11-Dec
Ellen Bakke	101	0		21-Nov
Erin Bakke	102	312	9	23-Oct
Dan Balderson	103	T331	7	7-Sep
Elizabeth Baldwin	104	616	8	3-Aug
Jenny Baldwin	105	124	3	14-Oct
Jordan Baldwin	106	616	7	3-Aug
Libby Baldwin	107	0		6-May
Laura Ballard	108	153	2	21-Oct
Heather Ballash	109	0		28-Jul
Jeess L. Ballenger	110	0		25-Nov
Myrah Ballentine	111	0		29-Nov
Mary Barger	112	0		25-Nov
Mindy Barker	113	0		1-Dec
Robert L. Barker	114	384	7	29-Oct

# Reforestation Tacoma Must Be Our Highest Priority

<u>Voter/Resident</u>	<u>ID</u>	<u>Page</u>	<u>Line</u>	<u>Date</u>
Douglass Barkley	115	162	1	23-Sep
Violet Barkley	116	162	2	23-Sep
Elliott Barnett	117	338	3	21-Oct
Kathleen Barnett	118	T329	6	7-Sep
Miriam Barnett	119	226	10	17-Oct
Amara Barnez	120	0		24-Dec
Christopher Barrans	121	333	5	21-Oct
Chraskine Barry	122	334	1	21-Oct
Alyssa Bartlett	123	0		3-Dec
Jamie Bartlett	124	0		15-Dec
Vicky Bartlett	125	0		4-Dec
Patrick Bartroff	126	117	10	23-Sep
Bernard A. Bates	127	4	6	2-Sep
Jillian L. Bates	128	4	7	2-Sep
Courtney Baxter	129	0		17-Nov
Wendy Bayman	130	0		21-Nov
Louisa Beal	131	0		7-Jul
Pamela Beal	132	0		1-Dec
Brynn Beals	133	0		28-Nov
Kelsey Bean	134	0		2-Dec
Revery Bean	135	0		23-Apr
Robert Bearden	136	0		21-Nov
Carmen Beaudry	137	0	0	21-Sep
Wayne Beck	138	317	10	31-Oct
Bert Bedford	139	0		29-Jun



# Reforestation Tacoma Must Be Our Highest Priority

<u>Voter/Resident</u>	<u>ID</u>	<u>Page</u>	<u>Line</u>	<u>Date</u>
Paige Beets	140	0		30-Nov
Caleb Behrmann	141	0		23-Nov
Jamie Beimford	142	0	0	20-Sep
Sadee Bekaert	143	0		25-Nov
Cheryl Ann Bell	144	0		30-Nov
Emilia Bell	145	0		2-Dec
Makenzie Bell	146	0		5-Dec
Michel Bellamy	147	123	10	14-Oct
Sara Bellamy	148	0		28-Nov
Kristine Bellizz	149	173	1	3-Oct
Kristina Bellizzi	150	659	7	7-Sep
Haze Bender	151	119	3	23-Sep
Sarah Benner	152	323	2	21-Oct
Anne Bennett	153	0		30-Nov
Peter Bennett	154	163	10	23-Sep
Susan Bennett	155	0		1-Aug
Mary Clare Benson	156	0		30-Nov
Marian Dorothy Berejikian	157	0		4-Dec
Janelle Palumbo Berford	158	117	3	23-Sep
Teresa Berg	159	111	2	2-Oct
Andrea Berger	160	0		4-Jul
Erin Conners Bergfield	161	0		27-Nov
Jason Berkowitz	162	83	9	15-Oct
Sonia Bermudez	163	636	6	3-Aug
Brooke Bernard	164	0		29-Nov

# Reforestation Tacoma Must Be Our Highest Priority

<u>Voter/Resident</u>	<u>ID</u>	<u>Page</u>	<u>Line</u>	<u>Date</u>
Brooke Bernard	165	0		22-Jul
Blake Berryham	166	161	5	23-Sep
Lynn Berstein	167	173	4	3-Oct
Mason Bert	168	387	9	28-Oct
Tower Bert	169	387	10	28-Oct
Cynthia Bertuzzi	170	T331	5	7-Sep
Ilona Berzups	171	0		11-Nov
Karyn Best	172	626	9	3-Aug
Tower Best	173	627	5	3-Aug
Tob Bet	174	11	1	11-Sep
Tobi Bet	175	T329	10	7-Sep
Malakay Betor	176	0		1-Dec
Judy Beylerian	177	326	3	29-Oct
Nisa Bhatia	178	0		1-Dec
Laura Bhatt	179	0		17-Nov
Samantha Biasca	180	0		22-Jul
Ann Marie Bickel	181	0		30-Jul
John Biggerstaff	182	801	2	3-Aug
Windy Biggerstaff	183	801	3	3-Aug
Scott Bilikas	184	0		22-Jul
Mark BIodeau	185	0		17-Aug
Chris Bily	186	0		27-Aug
bryan Birch	187	0		28-Aug
Courtney Bird	188	335	8	21-Oct
Jasmine Bird	189	177	10	8-Jun

## Reforestation Tacoma Must Be Our Highest Priority

<u>Voter/Resident</u>	<u>ID</u>	<u>Page</u>	<u>Line</u>	<u>Date</u>
Sara Bird	190	0		7-Sep
Brian Bischof	191	0		20-Dec
Janet Bissell	192	124	1	14-Oct
Alex Bittmann	193	0	0	22-Sep
Frances Blair	194	385	3	28-Oct
Frances E. Blair	195	2	1	24-Aug
Susan B. Blair	196	4	5	1-Sep
Alicia Blake	197	0		29-Nov
Elijah Blakeney	198	0		20-Nov
Cynthia Block	199	0		21-Nov
Nicholas Blodgett	200	0		20-Sep
Dawn Blomquist	201	0		23-Jul
Sally Bloom	202	0		12-Jun
Deb Blount	203	213	1	18-Nov
Nicole Blue	204	0		30-Jul
Andrew Bluett	205	0		4-Jun
Peter Bluett	206	117	6	23-Sep
Kelsey Bobeck	207	0		30-Nov
Vancy Bodenhorn	208	0		6-Jul
John Boerner	209	226	3	17-Oct
Jeff Boers	210	0		21-Nov
Allan Bogh	211	0		28-Nov
Tessa Bondi	212	209	8	28-Oct
Jared Bonea	213	0		22-Jul
Barbara G. Bonfield	214	0		27-Nov

# Reforestation Tacoma Must Be Our Highest Priority

<u>Voter/Resident</u>	<u>ID</u>	<u>Page</u>	<u>Line</u>	<u>Date</u>
Kanne Bonin	215	212	7	31-Oct
Kreauna Bonner	216	T328	9	7-Sep
Mary Boone	217	0		21-Nov
Megan Booth	218	704	8	3-Aug
Sam Booth	219	704	7	3-Aug
Melissa Borden	220	0		7-Dec
Mary Borgerding	221	0		23-Jul
Jourdan Bosley	222	0		23-Jul
Kelly Bosley	223	323	3	21-Oct
Cathleen Bostwa	224	315	5	26-Oct
McKenna Boulet	225	0		30-Nov
Jim Bowman	226	0		28-Jan
Kimberly Bowman	227	0	0	20-Sep
Penny Bowman	228	0		28-Jan
Martha Bowpen	229	42	4	20-Sep
Pamela M Boyd	230	165	1	23-Sep
Pamela M. Boyd	231	661	4	7-Sep
Patrick Boyle	232	612	5	3-Aug
Pamela J. Boyles	233	1	4	24-Aug
John M. Boynton	234	0		20-Sep
Matt Boynton	235	0		29-Nov
Anna Brabbins	236	705	9	3-Aug
Greta Brackman	237	0		21-Jan
Mary J. Bradford	238	327	8	21-Oct
Cathrine Bradley	239	318	10	1-Nov

## Reforestation Tacoma Must Be Our Highest Priority

<u>Voter/Resident</u>	<u>ID</u>	<u>Page</u>	<u>Line</u>	<u>Date</u>
Sarah Brady	240	210	10	26-Oct
Theadora Brand	241	0	0	20-Sep
Joyce Brannon	242	0		26-Nov
Deborah Bransford	243	111	4	2-Oct
Tarl Brese	244	0		1-Jul
Irene Brewer	245	0		9-Jun
Jennipher Brewer	246	386	8	28-Oct
Kenra Brewer	247	0		7-Jul
Torian K. Brewster	248	0		27-Nov
Linda Brieger	249	0		28-Mar
John L. Briehl	250	0		6-Jun
Chloe Briggs	251	0		8-Jan
Valerie Bright	252	210	1	26-Oct
Craig Britton	253	0		21-Nov
Sandy Brizuela	254	0		27-Aug
Lindsay Broman	255	0		26-Nov
Seth Broman	256	0		26-Nov
Dennis Brooke	257	118	2	23-Sep
Laurel Brooke	258	118	1	23-Sep
Kathleen Brooker	259	0		30-Jul
Jamie Brooks	260	327	1	21-Oct
Joseph Brooks	261	323	4	21-Oct
Renee Brooks	262	152	9	21-Oct
Thomas Brooks	263	152	8	21-Oct
Adam Brown	264	607	1	3-Aug

# Reforestation Tacoma Must Be Our Highest Priority

<u>Voter/Resident</u>	<u>ID</u>	<u>Page</u>	<u>Line</u>	<u>Date</u>
Amanda Brown	265	0	0	20-Sep
Callista Brown	266	0		1-Dec
Casey Brown	267	321	8	21-Oct
Chelsea Brown	268	607	2	3-Aug
Greer Brown	269	0		26-Nov
Gwynne Brown	270	0	0	22-Sep
Kelly Brown	271	82	4	5-Oct
Magic Brown	272	192	10	27-Sep
Pauline Brown	273	167	10	14-Oct
Sean J. Brown	274	0		28-Nov
Wynne Brown	275	0		18-Dec
Zora Brown	276	611	1	3-Aug
Kaitlyn Browning	277	0		16-Dec
Ken Brownlee	278	606	2	5-Aug
Patricia Bruce	279	0		10-Jun
Alice Bruns	280	0		29-Nov
Judy M. Bruns	281	0		27-Nov
Lansing Bryan	282	0		16-Aug
Lisa Btrey	283	164	2	23-Sep
Hailey Buchanan	284	0		29-Nov
Maddox Burgess	285	81	8	4-Oct
Sonja F. Burgess	286	0		23-Jul
Barbara Burke	287	0		11-Jan
Diane Burke	288	0		23-Nov
Sally Burke	289	0		5-Jan

# Reforestation Tacoma Must Be Our Highest Priority

<u>Voter/Resident</u>	<u>ID</u>	<u>Page</u>	<u>Line</u>	<u>Date</u>
Milissa A. Burkey	290	0		30-Nov
Aaron Burkhart	291	144	8	23-Nov
Stacy M. Burky	292	0		19-Dec
Chris Burns	293	173	2	3-Oct
Eunice M. Burns	294	0		26-Aug
Kit Burns	295	389	3	28-Oct
Rob Burns	296	0		12-Jan
Robert Burns	297	0		31-Jul
Zephyra Burt	298	705	6	3-Aug
Emilie Buter	299	0		23-Jul
John F. Butler	300	1	9	24-Aug
Johnny Butler	301	D	2	12-Jul
Robert Byron	302	311	2	26-Oct
Kyla Caddey	303	0		15-Dec
Deborah L. Cade	304	1	5	24-Aug
Ginabeth Cairns	305	0		27-Nov
Natalie Calungui	306	0		4-Jul
Devyn Cameron	307	0		22-Jul
Jordan Cameron	308	0		22-Jul
Chase Campbell	309	0		30-Nov
Debbie Campbell	310	T329	1	7-Sep
Jody Lee Campbell	311	0		13-Nov
Cary Campen	312	253	5	2-Nov
Raquel Campuzano	313	0		24-Jul
Kelly Canaday	314	0		24-Jun

## Reforestation Tacoma Must Be Our Highest Priority

<u>Voter/Resident</u>	<u>ID</u>	<u>Page</u>	<u>Line</u>	<u>Date</u>
Jose Candido	315	315	2	26-Oct
Catherine Candler	316	0		26-Nov
Missy Zenczak Candler	317	0		22-Jul
Douglas Cannon	318	629	3	3-Aug
Tony Cantrick	319	0		20-Nov
James Capecchi	320	0		25-Nov
Caleb Carbone	321	316	3	30-Oct
Nathan Cardozo	322	314	2	27-Oct
Mathew D. Carlson	323	333	9	21-Oct
Megan Carlson	324	333	8	21-Oct
John Carlton	325	0		23-Nov
Mary Carlton	326	0		3-Aug
Michael T. Carney	327	350	3	16-Nov
Natalie Caro	328	0		19-Sep
Nicholas Carr	329	170	8	23-Sep
Bill Carroll	330	609	2	3-Aug
Thomas P. Carroll	331	706	7	3-Aug
Tracy Carroll	332	706	6	3-Aug
Amy Carter	333	0		14-Dec
David W. Carter	334	0		1-Dec
Ella Carter	335	0		23-Jul
Ellis Carter	336	0		23-Jul
Laura Carter	337	0		29-Jun
Myles Carter	338	0		23-Jul
Lillian Casos	339	82	10	12-Oct



# Reforestation Tacoma Must Be Our Highest Priority

<u>Voter/Resident</u>	<u>ID</u>	<u>Page</u>	<u>Line</u>	<u>Date</u>
Maggie Cassel	340	0		26-Nov
Andrew Castille	341	0		28-Dec
Jose-Luis P. Castillo	342	388	2	26-Oct
Kaylee Castillo	343	0		4-Dec
Joshua Caswell	344	0		6-Dec
Jacqueline Cates	345	221	2	30-Sep
Susan Causey	346	0		6-Jul
Tiffany Cavin	347	118	8	23-Sep
Amy Cevans	348	0		7-Dec
Jenni Chadick	349	0		31-Dec
Ella Chamberlain	350	0		30-Nov
Jessica Chamberlain	351	0		29-Nov
Erin Chamberlin	352	325	7	27-Oct
Todd Chambers	353	0		7-Dec
Donna Chancellor	354	0		3-Jun
Kaitlin Chandler	355	0		4-Dec
Melanie Chang	356	A3	10	1-Nov
Carolyn Chapin	357	667	1	7-Sep
Claire Charles	358	632	2	3-Aug
Divaa Elon Charles	359	632	3	3-Aug
Kendyl Chasco	360	0		24-Nov
Matthew Chastain	361	0		23-Jul
Chan Chau	362	705	2	3-Aug
Clara Cheeves	364	0		16-Nov
Judith Chelotti	365	0		2-Jun

# Reforestation Tacoma Must Be Our Highest Priority

<u>Voter/Resident</u>	<u>ID</u>	<u>Page</u>	<u>Line</u>	<u>Date</u>
Malyssa Chen	366	0		26-Nov
Randy Cherland	367	0		28-Nov
Emily Chicone	368	627	7	3-Aug
William Devin Childress	369	0		9-Dec
Roman Christians	370	210	7	26-Oct
Mary Christie	371	388A	3	22-Dec
Christine	372	0		15-Dec
Maggie Christoffersen	373	626	1	3-Aug
Patrick Christoffersen	374	0		17-Nov
Christy	375	0		7-Jan
Cathy C. Chung	376	635	1	3-Aug
Barbara J. Church	377	330A	2	4-Feb
Mary Ann Clabaugh	378	0		7-Dec
Gregory Claire-Woldt	379	384	8	29-Oct
Peggy Clapp	380	616	1	3-Aug
Devon Clappe	381	636	5	3-Aug
Angela Clark	382	0		8-Dec
Angela Clark	383	0		12-Apr
Cody Clark	384	166	9	23-Sep
Joe Clark	385	611	3	3-Aug
Maureen Clark	386	611	2	3-Aug
Samantha Clark	387	212	4	29-Sep
April Clark-Walker	388	0		7-Jun
Andrew Clarke	389	211	2	18-Nov
Bronwyn Clarke	390	330	5	23-Feb

# Reforestation Tacoma Must Be Our Highest Priority

<u>Voter/Resident</u>	<u>ID</u>	<u>Page</u>	<u>Line</u>	<u>Date</u>
Darlene Clarke	391	0		2-Jul
Michael Clarke, Jr.	1,090	0		23-Jul
Alicia C Claudio	392	0		31-Jan
Elly Claus-McGahan	393	0		30-Nov
Kristy Clousing	394	630	9	3-Aug
Ricky Clousing	395	630	10	3-Aug
Amber Coffman	396	0		25-Nov
Dana Coggon	397	209	7	28-Oct
Emily Cohen	398	0		22-Jul
Keshet Cohen	399	317	4	30-Oct
O-Jan	400	0		21-Nov
James Colburn	401	2	5	24-Aug
Trina Colburn	402	124	2	14-Oct
Amy Cole	403	0		23-Jul
Celeste Cole	404	0		26-Nov
Bailey Coleman	405	0		11-Jun
Steven John Coleman	406	611	8	3-Aug
Travis Coleman	407	334	10	21-Oct
Cari Coll	408	667	2	7-Sep
Jodi Lee Collins	410	0		22-Jul
Liz Collins	411	T328	5	7-Sep
Ronald Collins	412	0	0	22-Sep
Will Collins	413	0		24-Nov
Julie Collison	414	0		26-Jan
John Columbo	415	626	7	3-Aug

## Reforestation Tacoma Must Be Our Highest Priority

<u>Voter/Resident</u>	<u>ID</u>	<u>Page</u>	<u>Line</u>	<u>Date</u>
Shaina Columbo	416	626	8	3-Aug
Susan Comis	417	225	1	15-Oct
Natalie Commins	418	318	7	8-Oct
Jane Compson	419	161	3	23-Sep
Jane F. Compson	420	0		26-Nov
Clay Compton	421	0		2-Sep
Darlene G. Conley	422	0		7-Jan
Eric Conner	423	0		30-Nov
Maria Conner	424	209	3	28-Oct
William Connolly	425	2	7	24-Aug
Allison Cook	426	0		7-Feb
David Cook	427	612	8	3-Aug
Jodi Cook	428	0		3-Oct
Megan Cook	429	609	1	3-Aug
Miles Cook	430	0		17-Nov
Tom Cook	431	0		7-Nov
Gabby Cooksay	432	311	7	26-Oct
Andrew Cooley	433	334	8	21-Oct
Karen Cooley	434	321	10	21-Oct
Jed Cooper	435	0		27-Nov
Chelsea Coopershear	436	338	1	21-Oct
Jessica Corddy	437	161	7	23-Sep
John Geoffrey Corso	438	2	2	24-Aug
Dali Cortes	439	0		15-Dec
Mary Cortez	440	381	2	29-Oct

# Reforestation Tacoma Must Be Our Highest Priority

<u>Voter/Resident</u>	<u>ID</u>	<u>Page</u>	<u>Line</u>	<u>Date</u>
Ella Cosentino	441	0		22-Jul
Donna Costi	442	0		9-Jun
Larry Cote	443	657	3	7-Sep
Michele Cotton	444	629	7	3-Aug
Damion Coughlin	445	0		23-Jul
Jennifer Coughlin	446	0		25-Jul
Frances Kay Coulter	447	0		30-Nov
Cathleen Countryman	448	0	0	21-Sep
Kristine Countryman	449	0		6-Dec
Jacob Cowan	450	0		27-Jun
John Cox	451	631	5	3-Aug
Rachel Cox	452	387	7	28-Oct
Roberta Cox	453	631	6	3-Aug
Gail Cram	454	0		30-Nov
Connie Crawford	455	667	8	7-Sep
Deborah Crawford	456	0		8-Jun
H. Frank Crawford	457	44	2	20-Sep
Suzi Crawford	458	83	8	15-Oct
Darryl Crews	459	385	1	28-Oct
Heather G. Crider	460	631	1	3-Aug
Allison Criswell	461	0		23-Jul
Francesca Crocker	462	0		11-Jun
Fletcher Crone	463	0		21-Feb
Alex Crook	464	611	7	3-Aug
Karley Crook	465	611	6	3-Aug

# Reforestation Tacoma Must Be Our Highest Priority

<u>Voter/Resident</u>	<u>ID</u>	<u>Page</u>	<u>Line</u>	<u>Date</u>
Patricia Crouch	466	612	4	3-Aug
Elizabeth Crouse	467	0		29-Nov
Elizabeth Crow	468	0		23-Jul
Michael Crowley	469	225	9	17-Oct
Susan Cruise	470	0		22-Nov
Cathy Cruver	471	T329	5	7-Sep
Alice Cryer	472	0		15-Dec
Robyn Curtis	473	701	6	3-Aug
Bronwyn Curve	474	C	2	13-Jun
Helen Cushman	475	667	10	7-Sep
Jasper Cushman	476	0		24-Nov
Victoria Czaplewski	477	41	10	20-Sep
Oriana D.	478	0		23-Jul
Isabella D'Amico	479	0		23-Jul
Marisa D'Angeli	480	0		3-Jul
David A. D'Aniello	481	313	3	27-Oct
Lisa D'Andrea	482	0		29-Nov
Sarah Daanen	483	0		30-Nov
Elizabeth Dada	484	211	4	18-Nov
Bailey Dahms	485	0		20-Nov
Scout Dahms-May	486	0		16-Feb
Wynter Dait	487	173	5	3-Oct
Whitney DalBalcon	488	0	0	20-Sep
Kathryn Dale	489	211	9	18-Nov
Lucas Damberg	490	385	9	28-Oct

## Reforestation Tacoma Must Be Our Highest Priority

<u>Voter/Resident</u>	<u>ID</u>	<u>Page</u>	<u>Line</u>	<u>Date</u>
Lucas Dambergs	491	0		22-Jul
Cassandra J. Damis	492	0		31-Dec
Herb Daniels	493	618	5	3-Aug
Katie Daniels	494	213	2	18-Nov
Sarah Daniels	495	618	6	3-Aug
Tyler Daniels	496	0		1-Dec
Mitchell Dasbro	497	115	6	23-Sep
Gabriella Davidson	498	0		6-Apr
Julie Davidson	499	0		11-Nov
Annie Davis	500	0		21-Jan
Clifford Davis	501	0		23-Nov
Courtney Davis	502	81	3	30-Sep
Daniel Davis	503	389	8	28-Oct
Jason Davis	504	0		1-Dec
Judith K. Davis	505	384	5	29-Oct
Karen Davis	506	0		1-Dec
Pamela Davis	507	616	2	3-Aug
Peter W. M. Davis	508	0		12-Jun
Quiana Davis	509	0		30-Nov
Ryan Davis	510	0		27-Nov
Esther G. Day	511	0		28-Nov
Robert Deamond	512	176	3	29-Oct
Diana Dearmin	513	0		23-Jul
Ruth S. Dekker	514	0		23-Jul
Denise DeLaFontaine	515	315	6	26-Oct

## Reforestation Tacoma Must Be Our Highest Priority

<u>Voter/Resident</u>	<u>ID</u>	<u>Page</u>	<u>Line</u>	<u>Date</u>
Holli Delaney	516	0		1-Jul
Barbara Delany	517	0		7-Nov
Shelly DeLeon	518	0		18-Nov
Chas DeLong	519	0		2-Dec
Debbie DeLong	520	0		2-Jun
Theresa DeMarco	521	0		25-Jun
Mary Denenal	522	113	3	3-Oct
William Leonard Denndochs	523	113	2	3-Oct
Logan Denney	524	0		17-Nov
Marilyn Denney	525	0		10-Jun
Robyn Denson	526	318	3	2-Nov
Genevieve Dettmer	527	0		25-Nov
Connor Devin	528	0		29-Aug
Felicity Devlin	529	0		3-Oct
Blaine DeVoy	530	0		29-Aug
Karen M. DeWitt	531	0		29-Nov
Vivian deZwager	532	191	1	18-Nov
Carson Diaz	533	0		24-Jul
Elmer Diaz	534	208	3	28-Oct
Sage Diaz	535	0		23-Jul
Sam Diaz	536	311	4	26-Oct
Brittany Dickerson	537	0		8-Jan
Rainbow Dickerson	538	325	3	27-Oct
Ann Dico	539	0		8-Jun
Jack Didier	540	0		17-Nov



## Reforestation Tacoma Must Be Our Highest Priority

<u>Voter/Resident</u>	<u>ID</u>	<u>Page</u>	<u>Line</u>	<u>Date</u>
Mic Didier	541	316	10	30-Oct
Ace Dieffenbach	542	210	4	26-Oct
Logun Dienberg	543	316	1	28-Oct
Irene Dilley	544	0		23-Nov
Karen Dinicola	545	191	9	3-Jan
Rick Dinicola	546	144	9	10-Jan
Keith Dmytrow	547	177	9	8-Jun
Jennifer Dnewland	548	0		30-Nov
Elizabeth Dobson	549	0		9-Dec
Jordan Robert Dobson	550	0		29-Jun
Liz Dobson	551	0		2-Jun
Alison Dodge	552	0		22-Jul
Jane Doe	553	0		23-Jul
John Doherty	554	83	6	15-Oct
Julia Dolan	555	333	10	21-Oct
Jacqueline Doman	556	0		11-Nov
M.E. Donovan	557	384	6	29-Oct
Karen Elizabeth Doten	558	0		10-Jun
Susan Doten	559	0		7-Jun
Elizabeth Douglas	560	0		16-Dec
Penelope Douglas	561	0		30-Nov
Brian Doyle	562	312	7	23-Oct
Eli Drake	563	0		1-Jul
Pamela Draper	564	0		6-Dec
Louise Dreyer	565	0		7-Jan

## Reforestation Tacoma Must Be Our Highest Priority

<u>Voter/Resident</u>	<u>ID</u>	<u>Page</u>	<u>Line</u>	<u>Date</u>
Diane Driscoll	566	177	7	8-Jun
Judy Droubay	567	253	3	2-Nov
Jesse Duarte	568	327	4	21-Oct
Jacqueline Duce	569	386	7	28-Oct
David T. Duckworth	570	0		22-Jul
Deborah Due	571	111	10	3-Oct
Cathy V. Duggan	572	0		21-Nov
Laureen Dulo	573	0		29-Nov
Thomas Duncan	574	634	4	3-Aug
Abby Dundon	575	333	3	21-Oct
Jeremiah Dunn	576	0	0	22-Sep
Rebecca Dunne	577	0		11-Jun
Ted Duran	578	0		24-Jul
Danielle Durand	579	0		30-Nov
Adrena Duval	580	389	7	28-Oct
Erin Dwyer	581	0		23-Jan
Samuel Dyachenko	582	0		26-Nov
Lori Dye	583	0		12-Jun
SDuzanne M. Dye	584	0		28-Nov
Lisa E. Dyer	585	0		2-Dec
Danielle Eagan	587	0		27-Nov
Danielle Eastin	588	0		11-Jun
Ashton Eather	589	0		23-Nov
Dan Eberhardt	590	659	2	7-Sep
Margaret Eberhardt	591	659	3	7-Sep

# Reforestation Tacoma Must Be Our Highest Priority

<u>Voter/Resident</u>	<u>ID</u>	<u>Page</u>	<u>Line</u>	<u>Date</u>
Chase Ebling	592	334	3	21-Oct
Carol Eckert	593	0		26-Nov
Richard Edwards	594	0		4-Dec
Luna Egan	595	0		26-Nov
Jennifer Egenolf	596	11	3	11-Sep
Michael Ehl	597	0		26-Nov
Arlee Ehlers	598	0		7-Jan
Susan M. Eidanzchink	1,319	B	5	13-Jun
Rebecca Eider	599	0		23-Jul
Samantha G. Eilert	600	0		23-Jul
Craig Eisenbarth	601	327	2	21-Oct
Justine Eister	602	0		25-Nov
Larry A. Eister	603	0		30-Jul
Nancy Eister	604	0		30-Jul
Leah Eister-Hargrave	605	0		30-Jul
Robert Elder	606	0		28-Dec
Cathy Elford	607	0		23-Nov
Vicki Elkins	608	616	5	3-Aug
Kathlean Ellingson	609	119	6	23-Sep
Daniel C. Elliott	610	707	7	3-Aug
Raney Ellis	611	0		24-Jul
Erika Ellison	612	0		1-Jul
Corinne Ells	613	0	0	20-Sep
Kristin Ely	614	0		29-Nov
Kathy Engle	615	629	8	3-Aug

## Reforestation Tacoma Must Be Our Highest Priority

<u>Voter/Resident</u>	<u>ID</u>	<u>Page</u>	<u>Line</u>	<u>Date</u>
Ashley Ernst	616	0		31-Jul
Gary Ernst	617	626	10	3-Aug
Amelia Escobedo	618	0		26-Jun
Valeria Martinez Espinoza	619	0		3-Jan
Susan Esqueda	620	0		23-Jul
Kay Estvold	621	615	7	3-Aug
Terry Estvold	622	615	6	3-Aug
Deborah Evans	623	0		2-Jun
Elizabeth Evans	624	0		6-Jul
Alicia Everson	625	334	9	21-Oct
June Everson	626	0		15-Dec
Marc Everson	627	0		24-Jul
Barry Ewing	628	667	5	7-Sep
Carmen Eyssautier	629	0		3-Sep
Rosemary F. Powers	630	B	4	13-Jun
Suzy Fairchild	631	636	9	3-Aug
Amanda Faker	632	0	0	20-Sep
Dennis Faker	633	0	0	20-Sep
Ruby Falciani	634	0		26-Nov
Charles J. Falskow	635	176	9	29-Oct
Sandy Farewell	636	0		22-Nov
Timothy Farrell	637	0		21-Nov
Erin Farris	638	801	8	3-Aug
Jason Farris	639	801	7	3-Aug
Jon Fayth	640	0		26-Nov

# Reforestation Tacoma Must Be Our Highest Priority

<u>Voter/Resident</u>	<u>ID</u>	<u>Page</u>	<u>Line</u>	<u>Date</u>
Obie Fayth	641	0		12-Jun
Domenick Federico	642	148	1	10-Jan
Katherine Fee	643	170	4	23-Sep
Catherine Feeney	644	B	1	7-Jun
Eric Feeney	645	0		22-Jul
Hayden Feeney	646	0		22-Jul
Maddie Feeney	647	0		22-Jul
Debby Mumm Felnagle	648	0		16-Nov
Nova Fergueson	649	0		22-Jul
Alexandro Fernandez	650	81	2	30-Sep
Nakanee Fernandez	651	0		11-Jun
Nakanée Fernandez	652	0		25-Nov
Raissa Fernandez	653	0		26-Nov
Nancy Ferree	654	0		29-Nov
Lloyd P. Fetterly	655	44	3	20-Sep
Patricia Fetterly	656	42	10	20-Sep
Mackenzie Feyedelem	657	0	0	20-Sep
Jordan Field	658	0		23-Jul
Victoria Fields	659	0		19-Sep
Karen Fierro	660	620	2	3-Aug
Mike Figueroa	661	655	7	7-Sep
Amy Filler-Katz	662	0		5-Jun
Anna H. Finch	663	0		22-Jul
Elizabeth Yina Finch	664	0		22-Jul
Mary Lou Finch	665	706	9	3-Aug

# Reforestation Tacoma Must Be Our Highest Priority

<u>Voter/Resident</u>	<u>ID</u>	<u>Page</u>	<u>Line</u>	<u>Date</u>
Michael Donald Finch	666	0		22-Jul
Raymond Finch	667	0		22-Jul
Natalie Findlay	668	41	5	20-Sep
Clara Louise Fink	669	662	2	7-Sep
Claudia Finseth	670	0		26-Nov
Wendy Stephens Firth	671	0		31-Dec
Don Fisher	672	316	2	28-Oct
Jason Fisher	673	0		29-Nov
Ryan Fisher	674	0		26-Jun
Dolores Fitch	675	0		30-Nov
Eileen Fitz-Faulkner	676	42	5	20-Sep
Elliott Fitzgerald	677	0		29-Dec
Pete Fives	678	387	8	28-Oct
Bryan Flint	679	T331	6	7-Sep
Sue Flint	680	315	4	26-Oct
Ellen Floyd	682	167	6	14-Oct
Patricia Flynn	683	0		27-Jul
Michael Foley	684	334	6	21-Oct
William Foley	685	334	7	21-Oct
Sue Folker	686	0		25-Nov
Joel Fonoimoana	687	0		23-Jul
Nicholas Ford	688	610	5	3-Aug
Robert Ford	689	338	2	21-Oct
Timothy M. Ford	690	661	9	7-Sep
Kevin Fordham	691	0		10-Dec

## Reforestation Tacoma Must Be Our Highest Priority

<u>Voter/Resident</u>	<u>ID</u>	<u>Page</u>	<u>Line</u>	<u>Date</u>
Kathryn Forest	692	386	9	28-Oct
Mark Formanek	693	620	10	3-Aug
Jan Forsyth	694	324	5	27-Oct
Sarah Foster	695	615	9	3-Aug
Shelli Foster	696	0		30-Nov
Piper Foulon	697	T330	6	7-Sep
Joice Fraizer	698	191	4	18-Nov
John Franklin	699	0		23-Jul
Norman Frasch	700	111	7	3-Oct
Branden Frauley	701	388	4	26-Oct
Travis Frazelle	702	0		30-Nov
Jared Fredeen	703	T328	7	7-Sep
Jessi Fredeen	704	T328	6	7-Sep
Catherine Frederickson	705	169	9	23-Sep
Launer Freedman	706	620	9	3-Aug
Ian Freeman	707	0		11-Dec
Kimberly Freeman	708	0		30-Nov
Aija French	709	163	2	23-Sep
Melanie Freshwaters	710	0		23-Jul
Athena Frey	711	0		26-Nov
Aubri Frey	712	0		21-Jan
Audrey Y. Frick	713	0		24-Nov
Elizabeth Lorraine Frick	714	0		26-Nov
Andrew Frostholt	715	0		22-Apr
Sean Fullerton	716	117	5	23-Sep

## Reforestation Tacoma Must Be Our Highest Priority

<u>Voter/Resident</u>	<u>ID</u>	<u>Page</u>	<u>Line</u>	<u>Date</u>
Carolyn J. Fulton	717	661	6	7-Sep
Kate Fulton	718	225	6	17-Oct
Fred D Fumia	719	655	5	7-Sep
Donna Funk	720	0		6-Jul
Molly Funk	721	0		6-Jul
Patricia Gabbard	722	0		20-Nov
Amy Gaither	723	0		7-Jul
Mary Galagan	724	0		8-Jul
Caleb Galbreath	725	0		23-Jul
David Galez	726	337	3	21-Oct
Felice Mercedes Gallego	727	0		26-Nov
Alexis Gallegor	728	630	4	3-Aug
Trevor Gallo	729	0		17-Nov
James Robert Gamble	730	0		27-Nov
Joe D Gann	731	657	1	7-Sep
Laura Gardner	732	0		27-Nov
Leah Gardner	733	0		30-Nov
Paul Garrison	734	705	5	3-Aug
Jean Garrity	735	0		21-Nov
Lisa Garza	736	T328	4	7-Sep
Jessica Gasper	737	625	1	3-Aug
Steven Gaydich	738	0		29-Aug
Benjamin Gearheard	739	0		21-Nov
Aregai Gebremedhin	740	0		1-Dec
Rebecca Geddie	741	0		30-Nov



## Reforestation Tacoma Must Be Our Highest Priority

<u>Voter/Resident</u>	<u>ID</u>	<u>Page</u>	<u>Line</u>	<u>Date</u>
Kerry Geffen	742	0		23-Jul
Tyler S. Gehring	743	0		23-May
Thomas Geibel	744	618	1	3-Aug
Mary Gelder	745	0		4-Dec
Nicholas Gerard	746	0		21-May
Caroline Gerner	747	387	3	28-Oct
Gage Gesford	748	0		1-Jan
Erika Geske	749	211	7	18-Nov
Beverly Gibson	750	655	2	7-Sep
Catherine Gifford	751	161	1	23-Sep
Claire Gifford	752	0		22-Jul
Joan Gilbert	753	169	2	23-Sep
Jenn Gile	754	0	0	23-Sep
Wayne Gilham	755	661	7	7-Sep
Greg Gillin	756	387	4	28-Oct
Angela Gilmore	757	618	7	3-Aug
Rob Gilmore	758	222	8	3-Dec
Stony Gilmore	759	313	5	27-Oct
Ted Gimlin	760	315	7	26-Oct
J. Ginnis	761	0	0	20-Sep
Tom Giske	762	1	1	24-Aug
Elaine Glen	763	117	9	23-Sep
Judee I. Glenn	764	0		11-Jan
Stacia Glenn	765	318	9	8-Oct
Glenn	766	0		5-Dec

## Reforestation Tacoma Must Be Our Highest Priority

<u>Voter/Resident</u>	<u>ID</u>	<u>Page</u>	<u>Line</u>	<u>Date</u>
Benjamin Glover	767	335	2	21-Oct
Gemini Gnull	768	0		22-Nov
Amanda Gobeli	769	0		7-Jul
Austin Goble	770	253	6	2-Nov
Catherine Goeddey	771	0		17-Jun
Willow Goetting	772	0		27-Jul
Susan Goetz	773	0		2-Jan
Melissa Goff	774	0		1-Jul
Carol Goforth	775	669	2	7-Sep
Carol Goforth	776	386	5	28-Oct
Edward Goldstein	777	655	3	7-Sep
Ana Gonzalez	778	325	4	27-Oct
Carma Gonzalez	779	208	1	28-Oct
Christina Gonzalez	780	0		23-Jul
Martha P. Gonzalez	781	0		24-Jul
Julia Gonzalez-Wolf	782	83	2	15-Oct
Josephj Gonzol	783	610	3	3-Aug
Michael Good	784	0		8-Sep
Carol Goodin	785	0		22-Jul
John O. Goodin	786	0		23-Jul
Nancy Goodin	787	213	4	18-Nov
Trystann Knight Goodman	788	0		5-Jul
Kelly Goodnight	789	0		23-Dec
Victoria Goodrich	790	0		29-Nov
Jesse Goodrum	791	0		5-Mar

## Reforestation Tacoma Must Be Our Highest Priority

<u>Voter/Resident</u>	<u>ID</u>	<u>Page</u>	<u>Line</u>	<u>Date</u>
Jamie Gordan	792	629	10	3-Aug
Jason Gordon	793	0		22-Nov
Melinda Gordon	794	0		25-Nov
Railene Gordon	795	0		22-Jul
William Gordon	796	0		27-Nov
Susan Gorman	797	0	0	22-Sep
Andrea Goubeaux	798	0		2-Jul
Marti Gould	799	701	1	3-Aug
Sadie Gould	800	626	6	3-Aug
Nona Govella	801	654	5	7-Sep
Tara Jean Grace	802	0		21-Jan
April Grady	803	0	0	21-Sep
Debra Grady	804	0	0	3-Oct
Neil M. Gray	805	0		27-Nov
Andryea M Grazier	806	0		24-Jul
Madeline Greeley	807	0		24-Jul
Donna Green	808	0		25-Nov
Kevin Green	809	626	2	3-Aug
Seth Greenbaum	810	0		9-Dec
Brian Greenhalgh	811	0	0	20-Sep
Stephani Gregg	812	704	3	3-Aug
Stephani J. Gregg	813	0		24-Nov
Daniel P. Grey	814	0		27-Aug
Bern Griffin	815	706	3	3-Aug
Geoff Griffin	816	0		25-Jul

## Reforestation Tacoma Must Be Our Highest Priority

<u>Voter/Resident</u>	<u>ID</u>	<u>Page</u>	<u>Line</u>	<u>Date</u>
Troy Griggs	817	0		23-Jul
David Grimes	818	702	4	3-Aug
Erin Groth	819	0		12-Jun
Katherine Groves	820	225	4	17-Oct
Sarah Grumbley	821	321	2	21-Oct
Jennifer Guadnola	822	0		30-Jul
Helen Guardado	823	0		26-Nov
Jess Guatney	824	0		26-Jun
Max Guerrero	825	0	0	22-Sep
Melissa Guerrero	826	0	0	22-Sep
Kacey Guin	827	0		27-Nov
Erica Gulliksen	828	0		1-Dec
Peter Gulsrud	829	166	5	23-Sep
Douglas Gwinn	830	2	8	24-Aug
XinTong H	831	0		29-Nov
Jack Haden-Enneking	832	0		22-Aug
Joe Hagen	833	A	8	30-Oct
Sharon Haggerty	834	0		8-Jun
Austin Hagley	835	704	4	3-Aug
Andrea Hague	836	0		28-Dec
Tracy Hahn	837	0		17-Nov
Susan Haigh	838	169	6	23-Sep
Harley Haines	839	226	1	17-Oct
Alison Hale	840	0		26-Nov
Lara Hale	841	0		26-Nov

# Reforestation Tacoma Must Be Our Highest Priority

<u>Voter/Resident</u>	<u>ID</u>	<u>Page</u>	<u>Line</u>	<u>Date</u>
Steven M. Hale	842	0		7-Dec
Thomas Hale	843	615	2	3-Aug
Mary Halese	844	705	4	3-Aug
Nancy B. Haley	845	703	6	3-Aug
Judy Halls	846	0		26-Nov
Judith K. Halstead	847	0	0	20-Sep
Clayton Hamill	848	0		25-Nov
Stevi Hamill	849	0		25-Nov
Kaylyn Hamiltoin	850	222	1	3-Dec
Megan Hamlin	851	0		2-Dec
Josh Hamm	852	630	1	3-Aug
Sera Han	853	0		28-Nov
John Hanby	854	116	4	23-Sep
Lana Hanford	855	0		29-Dec
Mary Hanneman	856	0		21-Nov
Ann Hansen	857	627	10	3-Aug
Laura Hansen	858	161	8	23-Sep
Leith Hansen	859	176	7	29-Oct
Shauna Hansen	860	659	5	7-Sep
Dan Hanson	861	631	4	3-Aug
Katherine Hanson	862	0		7-Jul
Annika Hansson	863	0		24-Jul
Dylan Hanwright	864	333	7	21-Oct
Stanton Harbaugh	865	0		2-Jan
Joyce Harden	866	0		23-Jul

# Reforestation Tacoma Must Be Our Highest Priority

<u>Voter/Resident</u>	<u>ID</u>	<u>Page</u>	<u>Line</u>	<u>Date</u>
Melody Hardesty	867	0		23-Jul
Karen Harding	868	388	6	28-Oct
Van Hardison	869	0		20-Sep
Arthur E. Hardwick, Jr.	870	0		26-Aug
Connie Hardy	871	152	10	21-Oct
Sophia Hardy	872	153	1	21-Oct
Kennis Harland	873	0		29-Nov
Thomas Harlow	874	165	8	23-Sep
Brad Harp	875	0		4-Jun
Kelly Harp	876	0		23-Jun
Susan Harp	877	0		4-Jun
James Joseph Harper	878	0		29-Dec
Jared Harper	879	701	2	3-Aug
Tahra Harper	880	314	1	27-Oct
William Harper	881	703	8	3-Aug
Danielle Harrington	882	0		14-Dec
Amber Harris	883	0		23-Nov
Molly Harris	884	621	4	3-Aug
Mary Ann Harshman	885	0		24-Jul
Christine Hartley	886	0		8-Jun
Suzan Hartley	887	0		8-Jun
Bradley Hartman	888	0		24-May
Joseph Hartman	889	0		30-Nov
Sierra Hartman	890	0		2-Dec
Jeff Hartson	891	0		1-Jan

## Reforestation Tacoma Must Be Our Highest Priority

<u>Voter/Resident</u>	<u>ID</u>	<u>Page</u>	<u>Line</u>	<u>Date</u>
Phil Harty	892	122	2	23-Sep
Phil S. Harty	893	0		7-Jul
Alan E. Harvey	894	117	1	23-Sep
Nancy J. Harvey	895	0		3-Jul
Katelyn Hassing	896	0		27-Aug
Rocky Hauge	897	651	3	7-Sep
Nancy Hausauer	898	0		20-Nov
Cindy Haverkamp	899	83	5	15-Oct
Richard Haverkamp	900	81	4	30-Sep
Jason Hays	901	386	3	28-Oct
Clair Hayes	902	0		24-Dec
Gwendolyn Hayes	903	0		1-Dec
Laura Haynes	904	0		26-Nov
Annette Hayward	905	0		7-Jul
Mustafa Haziq	906	0		1-Dec
B. Headley	907	0		23-Nov
Nicole Heckel	908	388	3	26-Oct
Gail Hecmanczuk	909	662	5	7-Sep
Richard Hecmanczuk	910	662	3	7-Sep
Jared Hedges	911	0		26-Nov
Doug Hedlund	912	0		6-Jun
Mollie Heilesen	913	42	8	20-Sep
Kevin Heinrich	914	0		3-May
Suzanne H. Hellar	915	0		22-Jul
John Hellman	916	165	4	23-Sep

## Reforestation Tacoma Must Be Our Highest Priority

<u>Voter/Resident</u>	<u>ID</u>	<u>Page</u>	<u>Line</u>	<u>Date</u>
Bon Henderson	917	0		28-Aug
Marilyn Henderson	918	0		22-Jul
Nancy E. Henderson	919	0	0	23-Sep
Roger C. Henderson	920	171	2	3-Oct
Amera Henley	921	0		29-Jun
Greg Henley	922	669	10	7-Sep
Mary Henley	923	669	9	7-Sep
Jennifer Hennessey	924	655	9	7-Sep
Daniel Hennessy-Sampson	925	124	8	14-Oct
Jonathan Hennessy-Sampson	926	124	7	14-Oct
Quincy Henry	927	0		4-Dec
Jonathon Hensley	928	0	0	23-Sep
Justin Hentges	929	0		26-Nov
Eric Herde	930	0		22-Jul
Mary Herem	931	388A	4	10-Jan
Austin Hernandez	932	317	9	31-Oct
Emily Hernandez	933	0		10-Nov
Gabrid Hernandez	934	618	8	3-Aug
Jennifer Hernandez	935	209	6	28-Oct
Peter Herpst	936	225	7	17-Oct
Rachel Hershberg	937	0		26-Nov
Bill Hessner	938	330B	1	23-Feb
Meara Heubach	939	0		13-Dec
Kathleen Hewitt	940	0		23-Nov
Roland Heyne	941	T331	3	7-Sep



## Reforestation Tacoma Must Be Our Highest Priority

<u>Voter/Resident</u>	<u>ID</u>	<u>Page</u>	<u>Line</u>	<u>Date</u>
Christine L. Hickey	942	0		27-Aug
Bearett Watson Hicks	943	0		28-Nov
William Wade Hicks	944	0		30-Jun
Molly Higgins	945	0		5-Dec
Jamie Hill	946	0	0	22-Sep
Kellen Hill	947	386	1	28-Oct
Lucas Hill	948	0	0	20-Sep
Shawn C. Hill	949	0		26-Nov
Marilee Hill-India	950	707	1	3-Aug
Jessica Hildorfer	951	0		27-Nov
Susan Hilsendeger	952	T329	9	7-Sep
Robert Himes	953	0		26-Nov
Mackenzie Hiner	954	628	8	3-Aug
David Hodel	955	999	2	3-Aug
John Hodgson	956	0		1-Sep
Marilynn Hoff	957	0		9-Jun
Renée Hoffman	958	617	10	3-Aug
Marion Hogan	959	0		16-Dec
Jacob Hogue	960	611	5	3-Aug
Mia Holbert	961	0		26-Nov
Rebecca Hollender	962	387	1	28-Oct
Robyn Hollingsworth	963	T329	8	7-Sep
Lauren Hollrah	964	0		29-Nov
Melissa Ann Holm	965	0		7-Jul
Travis Holmgren	966	314	9	28-Oct

## Reforestation Tacoma Must Be Our Highest Priority

<u>Voter/Resident</u>	<u>ID</u>	<u>Page</u>	<u>Line</u>	<u>Date</u>
Marissa Holshue	967	0		23-Jul
Genevieve Holstine	968	0		29-Nov
Sarah Holt	969	333	4	21-Oct
Daisy Holtzman	970	D	5	12-Jul
E. Holtzman	971	120	3	27-Sep
London Homer-Wambeam	972	0		28-Nov
Michael Honey	973	0		30-Jun
Linda Hood	974	325	2	27-Oct
Daniel A. Hoogen	975	0		20-Sep
Steve Hooper	976	0	0	21-Sep
Nancy Hope	977	0		6-Jul
John Hopper	978	0		16-Dec
Patrick Hopper	979	0		15-Dec
Christopher Horan	980	608	6	3-Aug
Daniel Hoult	981	0		28-Mar
LaVonna Houston	982	312	1	23-Oct
Sarah Hovan	983	386	10	28-Oct
Chase Hovinga	984	0		8-Sep
Ken Howes	985	0		29-Nov
Karl Huber	986	625	7	3-Aug
Mitchel Huber	987	0		29-Nov
Rosi Huber	988	625	8	3-Aug
Walter Hudsick	989	669	8	7-Sep
Dorothy Hudson	990	44	5	20-Sep
Marsha L. Huebner	991	0		29-Nov

# Reforestation Tacoma Must Be Our Highest Priority

<u>Voter/Resident</u>	<u>ID</u>	<u>Page</u>	<u>Line</u>	<u>Date</u>
Stephanie Huff	992	0		26-Jun
Martha Hughes	993	253	8	6-Nov
Joey Hulbert	994	0		20-Dec
Joseph M. Hulbert	995	0		5-Dec
Chantal Hulet	996	0		22-Nov
Laura Hull	997	0		4-Jan
Brian Humphreys	998	0		19-Feb
Erin Hunter	999	161	2	23-Sep
Whitney Huntley	1,000	0		26-Nov
Sazia Hussain	1,001	702	7	3-Aug
Heidi Hutchison	1,002	0		23-Jul
Darren Hutson	1,003	0		17-Feb
Shanna Hyatt	1,004	621	6	3-Aug
Amerita Igamma	1,005	320	7	8-Nov
Perla Ignacio	1,006	655	4	7-Sep
Andrew Imholt	1,007	0		27-Nov
Jennifer imholt	1,008	0		26-Nov
Michele Infusino	1,009	212	9	18-Oct
Laura Ingall	1,010	999	3	3-Aug
Laura Ingalls	1,011	317	6	31-Oct
Margaret Isenberg	1,012	221	7	1-Oct
Maya Itah	1,013	0		23-Jul
Shizuko Itsukaichi	1,014	0		9-Mar
Kirsten Iverson	1,015	0		8-Sep
Kristi Jackson	1,016	0		3-Jan

# Reforestation Tacoma Must Be Our Highest Priority

<u>Voter/Resident</u>	<u>ID</u>	<u>Page</u>	<u>Line</u>	<u>Date</u>
Shenf Jackson	1,017	B	9	13-Jun
Tabitha Jackson	1,018	703	4	3-Aug
Terese Jackson	1,019	0		16-Jun
Amy Jacobson	1,020	0		23-Jul
Mary L. Jaeger	1,021	612	7	3-Aug
Cassandra James	1,022	0		29-Nov
Christopher A. James	1,023	0		30-Nov
Michael Jamigoo	1,024	616	9	3-Aug
Sylvia Janeczek	1,025	0		30-Jul
Carolyn Janette	1,026	0		26-Nov
Felicity Janette	1,027	0		26-Nov
Felicity Janette	1,028	0		2-Jun
Krystina Jarvis	1,029	0		21-Nov
Christine Jauvil	1,030	0		26-Jul
Ian Jeffery	1,031	0		17-Nov
Render Jemis	1,032	0		26-Nov
Susan Jenkins	1,033	0		18-Jan
Chuck Jensen	1,034	0		17-Nov
Jean Marie Jensen	1,035	0		20-Nov
Jennifer Jensen	1,036	0		5-Jan
Jill Jensen	1,037	0		23-Nov
Kara Jensen	1,038	0		25-Nov
Kristy Jensen	1,039	0		25-Nov
Rob Jensen	1,040	0		23-Nov
Jennifer Jentlie	1,041	0		26-Nov

## Reforestation Tacoma Must Be Our Highest Priority

<u>Voter/Resident</u>	<u>ID</u>	<u>Page</u>	<u>Line</u>	<u>Date</u>
Sarah Jeter	1,042	0		28-Aug
Sydney Jew	1,043	628	7	3-Aug
Matthew Jewell	1,044	0		27-Jun
Emily Jiles	1,045	618	9	3-Aug
Brett M. Johnson	1,046	0		29-Nov
Dustin Johnson	1,047	0		11-Jun
Gunnar Johnson	1,048	0		1-Dec
Indy Johnson	1,049	0		7-Jul
Jenna Johnson	1,050	0		19-Sep
Kristin Johnson	1,051	0		15-Aug
Laura Johnson	1,052	617	8	3-Aug
Leah Johnson	1,053	617	5	3-Aug
Linda Johnson	1,054	0	0	21-Sep
Mark Johnson	1,055	617	7	3-Aug
Marsha C. Johnson	1,056	628	1	3-Aug
McKinley Johnson	1,057	0		26-Nov
Michael Johnson	1,058	0		30-Nov
Roger A. Johnson	1,059	1	3	24-Aug
Samuel Johnson	1,060	625	5	3-Aug
Sandra Johnson	1,061	0		21-Jan
Seth Johnson	1,062	0		4-Jan
Stuart Johnson	1,063	0		30-Nov
Wes Johnson	1,064	336	7	21-Oct
Zosia Johnson	1,065	0		21-Feb
Hallie Johnston	1,066	0		25-Nov

## Reforestation Tacoma Must Be Our Highest Priority

<u>Voter/Resident</u>	<u>ID</u>	<u>Page</u>	<u>Line</u>	<u>Date</u>
Karl Johnston	1,067	607	8	3-Aug
Kelli Johnston	1,068	0		5-Nov
Kristine A. Johnston	1,069	0		21-Nov
Monica Johnston	1,070	607	7	3-Aug
William F. Johnston	1,071	0		21-Nov
Ian Jol	1,072	385	10	28-Oct
Angela Jones	1,073	0		23-Nov
Brook Jones	1,074	0		3-Dec
Diane Marcus Jones	1,075	0		11-Dec
Ilene Jones	1,076	0		8-Jun
John Jones	1,077	0		21-Nov
Judith Jones	1,078	0		23-Nov
Katie Jones	1,079	621	3	3-Aug
Michele Jones	1,080	0		1-Dec
Michele Jones	1,081	0		22-Jul
Rick Jones	1,082	0		1-Dec
Rosemary Jones	1,083	0		29-Dec
Cindy Jorgensen	1,084	322	4	21-Oct
Dane Jorgensen	1,085	322	5	21-Oct
Dan Joslin	1,086	0		26-Jun
Khalsa Joslin	1,087	0		2-Jul
Alaina Joyce	1,088	0		16-Jul
Carolyn Joyce	1,089	388	8	29-Oct
Xiomara Juarez	1,091	0		24-Nov
Jenna Judge	1,092	122	4	23-Sep

# Reforestation Tacoma Must Be Our Highest Priority

<u>Voter/Resident</u>	<u>ID</u>	<u>Page</u>	<u>Line</u>	<u>Date</u>
Ariana Jugorap	1,093	164	5	23-Sep
Brandi Junderson	1,094	119	5	23-Sep
Lonnie Junderson	1,095	165	10	23-Sep
Marques Junior	1,096	389	9	28-Oct
Katy Juranty	1,097	0		3-Jan
Alex Kabaly	1,098	314	8	28-Oct
Julia Kagochi	1,099	0		16-Nov
McKenna Kalkbrenner	1,100	81	9	4-Oct
Linda Kammin	1,101	0		9-Jan
Michael Kaniecki	1,102	616	10	3-Aug
Marjut Karlsson	1,103	170	1	23-Sep
Maggie Karshner	1,104	0		24-Dec
Alicia Kay	1,105	706	4	3-Aug
Annie Ke	1,106	0		22-Jul
Neenah Kearn	1,107	0		22-Jul
Elizabeth L. Keathley	1,108	0		24-Jul
Julie Kee	1,109	0		3-Jun
Jill Keeton	1,110	0		30-Jun
Allison Kelanic	1,111	0		21-Nov
Keagan Keliher-Gay	1,112	0		22-Jul
Ruth Keller	1,113	0		4-Oct
Christopher Kelly	1,114	0	0	20-Sep
Ian Kelly	1,115	0	0	22-Sep
Jean Kelly	1,116	0	0	20-Sep
Laird Kelly	1,117	0		2-Dec

## Reforestation Tacoma Must Be Our Highest Priority

<u>Voter/Resident</u>	<u>ID</u>	<u>Page</u>	<u>Line</u>	<u>Date</u>
Robert Kelly	1,118	0	0	20-Sep
Sarah Kelly	1,119	0		15-Dec
William P. Kelly	1,120	385	6	28-Oct
JP Kemmick	1,121	335	9	21-Oct
Jeffrey Kendall	1,122	0		21-Nov
Matt Kendrick	1,123	0		15-Dec
Larry Kennedy	1,124	0		16-Feb
Drew Kerlee	1,125	0		22-Jul
Christine Kerr	1,126	612	1	3-Aug
David Kerr	1,127	612	2	3-Aug
E. Daniel Kerr	1,128	164	8	23-Sep
Laura Kesler	1,129	0		29-Nov
Wolf Kettunen	1,130	0		20-Nov
Karen B. Kiehlmeier	1,131	0		5-Dec
Noreen Kilpatrick	1,132	0		26-Nov
Scott Kilts	1,133	0		6-Dec
Marilyn Kimmerling	1,134	0		7-Jan
Kelsey Kimura	1,135	0		26-Nov
Carol Kindt	1,136	0		27-Nov
Deborah Kinerk	1,137	0	0	21-Sep
John King	1,138	667	3	7-Sep
Laura King	1,139	0		1-Dec
Nikki King	1,140	667	4	7-Sep
Susan King	1,141	0		4-Jun
Teresa King	1,142	0		26-Nov



# Reforestation Tacoma Must Be Our Highest Priority

<u>Voter/Resident</u>	<u>ID</u>	<u>Page</u>	<u>Line</u>	<u>Date</u>
Karen Kints	1,143	151	8	21-Oct
Brandon Kirkham	1,144	707	4	3-Aug
Kathy Klianer	1,145	628	6	3-Aug
Julia Klinestiver	1,146	0		7-Jan
Stacey A. Klinzman	1,147	4	1	27-Aug
Deborah Kloby	1,148	0		23-Jan
Soren Kloepher	1,149	82	5	5-Oct
Laura Klosterman	1,150	0		23-Nov
Donavon Klug	1,151	164	10	23-Sep
Laura Klug	1,152	0		21-Nov
Kenzie Knapp	1,153	81	6	30-Sep
Karan Knitchman	1,154	163	4	23-Sep
Chloe Knopf	1,155	0		26-Nov
James Knopf	1,156	212	10	18-Oct
Melissa Knott	1,157	0		25-Aug
Charlene Rae Knowles	1,158	0		1-Dec
Nancy G. Knudsen	1,159	1	11	24-Aug
Gary Knudson	1,160	654	1	7-Sep
Gary Knudson	1,161	0	0	22-Sep
Brandon Koch	1,162	608	10	3-Aug
Daniel B. Koch	1,163	0		22-Jun
Derek Koch	1,164	615	10	3-Aug
Brenda Kodama	1,165	41	8	20-Sep
Blake Koehn	1,166	0		23-Jul
Emily Koehn	1,167	0		25-Jul

# Reforestation Tacoma Must Be Our Highest Priority

<u>Voter/Resident</u>	<u>ID</u>	<u>Page</u>	<u>Line</u>	<u>Date</u>
Erin Koene	1,168	615	3	3-Aug
Ellen Kohjima	1,169	112	8	3-Oct
Peter J. Kok	1,170	253	4	2-Nov
Peter J Kok Jr	1,171	T330	9	7-Sep
Anthony Koleszar	1,172	0		23-Jan
Jessica Kolva	1,173	122	1	23-Sep
Tanner Kongfit	1,174	631	9	3-Aug
Anastasia Kopcha	1,175	0		5-Dec
Susan Koppelman	1,176	0		6-Jul
Andrew Kouklis	1,177	166	2	23-Sep
Mary Beth Kovanen	1,178	0		1-Dec
Keri Parker Kragh	1,179	0		8-Jun
Andrew Krajewski	1,180	327	7	21-Oct
Robb Krehbiel	1,181	192	4	23-Sep
Christine Kreis	1,182	625	2	3-Aug
Alex Krejci	1,183	0		3-Mar
Alex Kress	1,184	618	2	3-Aug
Janel Krilich	1,185	83	4	15-Oct
Stephanie Krilich	1,186	124	5	14-Oct
Katy Krippaehne	1,187	625	10	3-Aug
Scott Krippaehne	1,188	625	9	3-Aug
Pat Krueger	1,189	0		15-Dec
David Kuehn	1,190	118	5	23-Sep
Jennifer Halverson Kuehn	1,191	0		3-Dec
Kimberly Kueter	1,192	0		23-Nov

## Reforestation Tacoma Must Be Our Highest Priority

<u>Voter/Resident</u>	<u>ID</u>	<u>Page</u>	<u>Line</u>	<u>Date</u>
James Kuhlman	1,193	0	0	23-Sep
Kukuya	1,194	0		6-Dec
DiAnna Kurriger	1,195	115	1	23-Sep
Bruce LaBar	1,196	0		18-Dec
John Gus Labayen	1,197	704	5	3-Aug
Jordan Labayen	1,198	704	6	3-Aug
Steve LaBerg	1,199	322	9	21-Oct
Amy Kendall LaBree	1,200	0		23-Jul
Jennifer Lacy	1,201	318	8	8-Oct
Bob LaFerriere	1,202	632	9	3-Aug
Donna LaFerriere	1,203	632	10	3-Aug
Brian LaFreniere	1,204	0		30-Nov
Michael Lafreniere	1,205	0		20-Nov
Martha Lambert	1,206	0		1-Dec
Brianna Lammi	1,207	192	8	27-Sep
Jennifer Lane	1,208	0		28-May
Jennifer Lane	1,209	0		28-May
Stephanie Langenderfer	1,210	0	0	22-Sep
Kathryn Lanzillo-Hidalgo	1,211	0		16-Dec
Debra Lara	1,212	0		23-Nov
Elisse LaRoche	1,213	0		15-Dec
Susan B. Larrivee	1,214	609	7	3-Aug
Debra Larsen	1,215	221	10	1-Oct
Scott Larsen	1,216	221	9	1-Oct
Roberta Larson	1,217	384	10	29-Oct

# Reforestation Tacoma Must Be Our Highest Priority

<u>Voter/Resident</u>	<u>ID</u>	<u>Page</u>	<u>Line</u>	<u>Date</u>
Wayne Larson	1,218	111	1	2-Oct
Jennifer Laycock	1,219	0		7-Jun
Suzy Lebel	1,220	170	10	23-Sep
Alisa Lee	1,221	330	3	23-Feb
Catherine Lee	1,222	0		17-Nov
David Lee	1,223	324	8	27-Oct
Eric Lee	1,224	0		22-Nov
Jon Lee	1,225	324	9	27-Oct
Julie Lee	1,226	0		1-Jul
Zana Lee	1,227	0		6-Nov
Tonya Legault	1,228	0		7-Jan
Elizabeth Leines	1,229	0		7-Jul
John Lelko	1,230	612	6	3-Aug
Aviva Lemberger	1,231	0		27-Aug
Darin Lenderink	1,232	401	2	22-Feb
Karen Linderink	1,233	401	3	22-Feb
Matthew Lenett	1,234	0		2-Dec
Echo Lenss	1,235	0		24-Jul
Anna Leon	1,236	226	2	17-Oct
Tey Anjulee Leon	1,237	320	1	1-Nov
Alexis Leong	1,238	0		26-Nov
Ray Lepore	1,239	0		25-Nov
Sue L. Lepore	1,240	171	4	3-Oct
Jessica Leslie	1,241	320	2	1-Nov
Kristen Lester	1,242	0	0	20-Sep

## Reforestation Tacoma Must Be Our Highest Priority

<u>Voter/Resident</u>	<u>ID</u>	<u>Page</u>	<u>Line</u>	<u>Date</u>
Laurence Adam Leveen	1,243	0		5-Dec
Katherine N. Levesque	1,244	0		26-Nov
Michelle Levey	1,245	0		21-Nov
Byron Lewin	1,246	0		22-Jul
Frank Russ Lewis	1,247	152	5	21-Oct
Gabrielle Lewis	1,248	0		2-Jul
Paige Lewis	1,249	0		26-Dec
Pam Lewis	1,250	152	4	21-Oct
Ty Lewis	1,251	167	2	23-Sep
Anna Lieck	1,252	335	3	21-Oct
Demian Lieck	1,253	335	4	21-Oct
Lynn Lightwell	1,254	0		23-Jul
Patricia Lynn Lightwell	1,255	661	5	7-Sep
Kristin Marie Lillegard	1,256	0		20-Jun
Marianne Lincoln	1,257	0		20-Aug
Janet Fleming Lind	1,258	0		27-Nov
Linda	1,259	0		6-Dec
Christine Lindquist	1,260	0		5-Dec
Christine Lindquist	1,261	0		30-Jun
Lauri Lindquist	1,262	0		2-Dec
Bob Lindstrom	1,263	654	4	7-Sep
Bonnie Lindstrom	1,264	166	6	23-Sep
Robert Lindstrom	1,265	166	7	23-Sep
Jason A. Line	1,266	311	1	26-Oct
Annie Lingrin	1,267	626	4	3-Aug

# Reforestation Tacoma Must Be Our Highest Priority

<u>Voter/Resident</u>	<u>ID</u>	<u>Page</u>	<u>Line</u>	<u>Date</u>
Lori Lioy	1,268	315	8	26-Oct
Richard Lioy	1,269	315	9	26-Oct
Michael Lipko	1,270	0		9-Mar
Lisa	1,271	0		25-Nov
Lori-Lee Litman	1,272	C	1	13-Jun
Joshua Little	1,273	0		23-Jul
Mary C. Lobdell	1,274	0		30-Nov
Benjamin LoBue	1,275	0		5-Dec
Madi Lockhart	1,276	0		12-Jun
Sharon Loder	1,277	0		9-Jun
Zane Lohr	1,278	0		29-Jul
Kenin Loken	1,279	155	2	27-Oct
John De Loma	1,280	0		3-Jun
Brian Lomheim	1,281	607	3	3-Aug
Sheryll Lomheim	1,282	607	4	3-Aug
Leonard Long	1,283	0		30-Jun
Tricia M. Long	1,284	0		20-Nov
Matt Lonsdale	1,285	0		22-Jul
Katherine Loomis	1,286	0		22-Nov
Benjamin Looney	1,287	0		6-Dec
Christian Lopez	1,288	337	5	21-Oct
Margaret Love	1,289	0		28-Aug
Terrilee Love	1,290	151	5	21-Oct
Thomas E. Love	1,291	151	4	21-Oct
David Lovejoy	1,292	152	2	21-Oct

## Reforestation Tacoma Must Be Our Highest Priority

<u>Voter/Resident</u>	<u>ID</u>	<u>Page</u>	<u>Line</u>	<u>Date</u>
Alicia Lovins	1,293	611	9	3-Aug
Seth Lovins	1,294	611	10	3-Aug
Sarah Low	1,295	123	6	14-Oct
Katherine Lowe	1,296	0		22-Jul
Jennifer Lowery	1,297	0		27-Nov
Katrina Lowy	1,298	151	9	21-Oct
Ying Loyola	1,299	0		21-Nov
Mikaela Luarca	1,300	0		29-Nov
Jillian Lubow	1,301	0		22-Jul
Isaac Luedtke	1,302	311	3	23-Oct
Roger E Luek-Mammen	1,303	151	2	21-Oct
Rosalyn L. Luek-Mammen	1,304	151	1	21-Oct
Julianne Lukana	1,305	706	8	3-Aug
Jeanette Lunceford	1,306	176	2	29-Oct
Ronald D. Lunceford	1,307	176	1	29-Oct
Amy Lundquist	1,308	0	0	22-Sep
Zan Lussior	1,309	336	1	21-Oct
Suzy Lutey	1,310	0		7-Jan
Quinn Luthy	1,311	0		19-Dec
Kathrynn Lyle	1,312	0		10-Jan
MaryAnne Lyman	1,313	661	1	7-Sep
Alice Lynch	1,314	801	6	3-Aug
Stephen Lynch	1,315	0		1-Dec
Dfustin Lynn	1,316	211	3	18-Nov
C. Lyon	1,317	327	3	21-Oct

# Reforestation Tacoma Must Be Our Highest Priority

<u>Voter/Resident</u>	<u>ID</u>	<u>Page</u>	<u>Line</u>	<u>Date</u>
Megan M	1,318	0		5-Mar
Allan Maas	1,320	0		14-Jan
Kallie Maas	1,321	0		23-Jul
A. L. Macdonald	1,322	11	2	11-Sep
Kim Mace	1,323	213	3	18-Nov
Diane Macfarlane	1,324	0	0	22-Sep
Casey MacGill	1,325	0		7-Jan
Josh Machniak	1,326	0		12-Jun
Marcia Madden	1,327	0		22-Jul
Teddy Maddie	1,328	386	4	28-Oct
Sonja Maddox	1,329	659	8	7-Sep
Sonja Maddox	1,330	0		2-Dec
Nehemiah Madison	1,331	212	3	29-Sep
Haylee Madsen	1,332	0		12-Jun
Jennifer Maietta	1,333	0		20-Nov
Dan Maize	1,334	0		22-Jul
Michele Maize	1,335	0		22-Jul
Charlotte Malkmus	1,336	0		22-Nov
Conner Maller	1,337	313	10	27-Oct
Bidisher Mallik	1,338	350	7	16-Nov
Bidisha Mallile	1,339	702	3	3-Aug
Melissa Malott	1,340	0		7-Dec
Audrey Maloy	1,341	0		28-Nov
Amber Mandez	1,342	388	5	28-Oct
Jeremy Maneja	1,343	166	1	23-Sep



## Reforestation Tacoma Must Be Our Highest Priority

<u>Voter/Resident</u>	<u>ID</u>	<u>Page</u>	<u>Line</u>	<u>Date</u>
Carlo C. Manetti	1,344	0		26-Nov
Christina Manetti	1,345	0		3-Dec
Judith Manetti	1,346	0		26-Nov
Luke Mann	1,347	192	3	23-Sep
Magnuss Mansson	1,348	701	4	3-Aug
Frank Manthou	1,349	118	4	23-Sep
Judi Manthou	1,350	118	3	23-Sep
Jordan Manville	1,351	0		30-Nov
J. Maplethorpe	1,352	211	1	18-Nov
Sean Maplethorpe	1,353	211	5	18-Nov
Lalenia Maria	1,354	0		25-Oct
Olivia Mariettakes-Reed	1,355	0		7-Dec
Anthony Marino	1,356	0		24-Nov
Anna Markee	1,357	0		10-Jun
Jennifer Markestad	1,358	0		10-Aug
Sorg Marlane	1,359	0		8-Nov
Philip Marr	1,360	0	0	23-Sep
Paula Marsh	1,361	0		24-Jul
Melody Martel	1,362	0		27-Jun
Susanne Marten	1,363	0		27-Nov
David Martens	1,364	0		2-Jan
Brenda Martin	1,365	0	0	21-Sep
Christine Martin	1,366	0		26-Jul
Jaclyn Martin	1,367	312	5	23-Oct
Judith J Martin	1,368	350	6	16-Nov

## Reforestation Tacoma Must Be Our Highest Priority

<u>Voter/Resident</u>	<u>ID</u>	<u>Page</u>	<u>Line</u>	<u>Date</u>
Nicholas Martin	1,369	324	1	26-Oct
Roger Martin	1,370	0		19-Sep
Andrew Martinez	1,371	313	2	27-Oct
Antonio Martinez	1,372	0		26-Nov
Christi Martinez	1,373	0		24-Jul
Christopher Martinez	1,374	608	2	3-Aug
Lucy Martinez	1,375	0		23-Jul
Megan Martinez	1,376	82	8	11-Oct
Michelle Martinez	1,377	0	0	22-Sep
Suzane Sampaio Martinez	1,378	0		7-Feb
Linda Marvik	1,379	0		7-Nov
Mary	1,380	0		1-Dec
Joshua Materi	1,381	0		6-Mar
Alexandra Mather	1,382	170	7	23-Sep
Cassandra Mathews	1,383	222	7	3-Dec
Elias Mathias	1,384	336	8	21-Oct
Kimberle Matison	1,385	0		24-Jul
Monique Matlock	1,386	155	1	24-Oct
Alyssa Matthews	1,387	0		29-Nov
Robert I. Matthews	1,388	0		2-Sep
Ed Mattison	1,389	B	8	13-Jun
Rose Mattison	1,390	0		25-Nov
Katie Mattran	1,391	0		15-Dec
Deirdre Maxwell	1,392	0		29-Nov
James May	1,393	0		29-Aug

## Reforestation Tacoma Must Be Our Highest Priority

<u>Voter/Resident</u>	<u>ID</u>	<u>Page</u>	<u>Line</u>	<u>Date</u>
Michelle May	1,394	167	3	23-Sep
Monika May	1,395	0		7-Jan
Stefanie May	1,396	311	3	26-Oct
Deven Colleen Mayes	409	212	1	29-Sep
Keith Mayo	1,397	0		5-Dec
Rachel Mayo	1,398	0		26-Jun
Eddie Mazariegos	1,399	704	1	3-Aug
Thabisa Mazur	1,400	0		8-Sep
Lindsay McAdams	1,401	632	4	3-Aug
Diane McAlister	1,402	3	2	24-Aug
Harry McAlister	1,403	3	4	24-Aug
Elizabeth McAmis	1,404	655	6	7-Sep
Elizabeth McAmis	1,405	0		2-Sep
Wayne B McAnis	1,406	T330	10	7-Sep
Matt Mcauer	1,407	144	3	2-Nov
Dorothy McBride	1,408	112	4	3-Oct
Melissa McBurney	1,409	0		22-Jul
Dorothy McCabe	1,410	0		8-Feb
Miriam McCabe	1,411	210	5	26-Oct
Thomas McCabe	1,412	0		21-Nov
Elisabeth McCarthy	1,413	0		23-Jul
Gina M. McCarthy	1,414	0		8-Jun
Joshua McCarthy	1,415	0		7-Jun
Matthew Stephen McCarthy	1,416	0		7-Jun
Robin McCarthy	1,417	0		28-Jun

## Reforestation Tacoma Must Be Our Highest Priority

<u>Voter/Resident</u>	<u>ID</u>	<u>Page</u>	<u>Line</u>	<u>Date</u>
Cory McCauley	1,418	387	5	28-Oct
Marshall McClintock	1,419	1	2	24-Aug
Sarah McClintock	1,420	0		23-Jul
Kathleen McClone	1,421	707	9	3-Aug
Clinton McCloud	1,422	0		9-Dec
David McCord	1,423	701	3	3-Aug
Alicia McCormick	1,424	0		23-Nov
Nolan Dale McCormick	1,425	0		25-Nov
Tristan McCoy	1,426	0		15-Dec
Sena McDaniel	1,427	619	3	3-Aug
Patrick McDermott	1,428	320	8	8-Nov
Max McDonald	1,429	0		23-Jul
Timothy B. McDonald	1,430	329	10	22-Feb
Naarh R. McDonald-Kelley	1,431	315	1	26-Oct
Lezley McDouall	1,432	0		20-Sep
Chelsea McElroy	1,433	0		15-Nov
Kaden McElroy	1,434	316	6	29-Oct
Lydia McElroy	1,435	607	9	3-Aug
Matthew McFall	1,436	0		28-Nov
Nancy McFarland	1,437	0		24-Jul
Melissa McGinnis	1,438	667	9	7-Sep
Melissa S. McGinnis	1,439	636	2	3-Aug
Benjamin McGrath	1,440	0		23-Jul
Karen McGrath	1,441	42	2	20-Sep
Matthew McGrath	1,442	0		17-Nov

## Reforestation Tacoma Must Be Our Highest Priority

<u>Voter/Resident</u>	<u>ID</u>	<u>Page</u>	<u>Line</u>	<u>Date</u>
Linda McGrea	1,443	389	1	28-Oct
John McGregor	1,444	636	8	3-Aug
Juli McGruder	1,445	225	3	17-Oct
Jay Michael McGuire	1,446	636	1	3-Aug
Scott McHugh	1,447	617	4	3-Aug
Alex McKee	1,448	0		21-Jan
Annette McKelvey	1,449	0		24-Jul
Kieran McKenna	1,450	316	3	28-Oct
Jeff McKenzie	1,451	657	8	7-Sep
Susan C. McKenzie	1,452	112	7	3-Oct
Daniel McKeown	1,453	0		29-Nov
Beverly McKinney	1,454	0		26-Nov
Christina McLamore	1,455	0		31-Jul
Alyssa McLellan	1,456	0		7-Aug
Roger D. McLennan	1,457	384	2	29-Oct
Marnie McManus	1,458	0		23-Jul
Harold McMichael	1,459	192	9	27-Sep
Patricia McNeal	1,460	0		22-Jul
Kellianne McNeil-O'Hagan	1,461	0		8-Jun
Mitch McQuigg	1,462	325	8	27-Oct
Simoa Medisah	1,463	615	8	3-Aug
Bonnie Medlock	1,464	0		8-Jun
Alycia Melendez	1,465	661	8	7-Sep
Thomas Melot	1,466	0		10-Jan
Martha Anne Mendenhall	1,467	0		25-Nov

## Reforestation Tacoma Must Be Our Highest Priority

<u>Voter/Resident</u>	<u>ID</u>	<u>Page</u>	<u>Line</u>	<u>Date</u>
Barbara Menne	1,468	83	10	15-Oct
Barbara Menne	1,469	0		3-Jun
Gary Merlin	1,470	325	9	27-Oct
Jeffrey Merritt	1,471	0		22-Jul
Taylor Merwin	1,472	0		23-Jul
Devan Meyer	1,473	0		5-Dec
Georgi Meyer	1,474	0		12-Jun
Nancy Meyer	1,475	0		8-Jun
Nicole Meyer	1,476	619	4	3-Aug
Norman Christian Meyer	1,477	0		8-Jun
Steve Meyer	1,478	320	4	1-Nov
Carmela Micheli	1,479	0		6-Jul
Margaret Mickelson	1,480	0		4-Dec
Valerie Middleton	1,481	0		26-Nov
James Milam	1,482	0		24-Nov
Elizabeth Milburn	1,483	0		19-Dec
Patrick Miles	1,484	0		28-Nov
Alana Miller	1,485	0		22-Jul
Dustin Miller	1,486	0		26-Nov
Elizabeth K. Miller	1,487	173	8	3-Oct
Julie Miller	1,488	0		23-Nov
Katherine Miller	1,489	389	6	28-Oct
Lila Miller	1,490	0		23-Jul
Cindy Milligan	1,491	0		30-Nov
Helen Milus	1,492	0		6-Jan

# Reforestation Tacoma Must Be Our Highest Priority

<u>Voter/Resident</u>	<u>ID</u>	<u>Page</u>	<u>Line</u>	<u>Date</u>
Tye Minckler	1,493	171	1	3-Oct
Samantha Mineo	1,494	0		30-Jun
Amanda Minnis	1,495	0		20-Nov
Beczahaida Miranda	1,496	337	6	21-Oct
Spint Misk	1,497	337	2	21-Oct
Andrew Mitchell	1,498	0		23-Jul
Cynthia Mitchell	1,499	0		28-Nov
James W. Mitchell	1,500	116	2	23-Sep
Robert Mittal	1,501	706	2	3-Aug
Emily Mitzel	1,502	0		27-Nov
Janice Miura	1,503	617	2	3-Aug
Lawrence Miura	1,504	617	3	3-Aug
Maddy Mixter	1,505	0		26-Jun
Anthony Mizumori	1,506	0		24-Nov
Marin Moafe	1,507	606	4	5-Aug
Kathy Moates	1,508	111	6	3-Oct
Randee Moll	1,509	316	4	29-Oct
Richard Monce	1,510	0		22-Nov
Rick Monce	1,511	329	7	22-Feb
Flor Moner	1,512	209	1	28-Oct
M Monford	1,513	669	6	7-Sep
Tad Monroe	1,514	221	5	1-Oct
Brittany Montague	1,515	632	5	3-Aug
Isiah Montejano	1,516	659	1	7-Sep
Michelle S. Mood	1,517	0		1-Dec

## Reforestation Tacoma Must Be Our Highest Priority

<u>Voter/Resident</u>	<u>ID</u>	<u>Page</u>	<u>Line</u>	<u>Date</u>
Georgia Moody	1,518	0		26-Jul
Kathryn Moon	1,519	0		28-Dec
Mace Mooney	1,520	0		17-Nov
Melanie Moor	1,521	0		25-Nov
Albrecht Moore	1,522	0		27-Aug
Benita Moore	1,523	0		24-Nov
Charles Moore	1,524	155	3	27-Oct
Ellen Moore	1,525	0		15-Dec
Lynne Moore	1,526	0		26-Aug
Ryan Moore	1,527	0		1-Jul
Shannon Moore	1,528	0	0	23-Sep
Sloan Moore	1,529	0		17-Nov
Gabriel Moorehead	1,530	0		18-Nov
Maria Mora	1,531	385	5	28-Oct
Michael Moran	1,532	659	9	7-Sep
Raquelle Moreau	1,533	335	1	21-Oct
Christopher Moreno	1,534	669	7	7-Sep
Kathleen Morford	1,535	608	4	3-Aug
Randal Morford	1,536	608	5	3-Aug
Alex Morganroth	1,537	11	9	11-Sep
Dana Morganroth	1,538	0		2-Jan
Timothy Mork	1,539	0		2-Sep
Karin Morris	1,540	0		25-Jul
Daniel Morrison	1,541	0		22-Jul
Bruce W. Morse	1,542	0		5-Dec



## Reforestation Tacoma Must Be Our Highest Priority

<u>Voter/Resident</u>	<u>ID</u>	<u>Page</u>	<u>Line</u>	<u>Date</u>
Betsy Moschetti	1,543	324	7	27-Oct
Carla Moschetti	1,544	0		6-Jun
Marshall Mosely	1,545	115	3	23-Sep
Matthew Mosely	1,546	115	2	23-Sep
Lauren Moseman	1,547	0		13-Jan
Milo Moss	1,548	0		20-Jan
Marlene Motola	1,549	0		6-Sep
Julie Moylan	1,550	0		22-Jul
Thomas Moylan	1,551	167	8	14-Oct
Eric Mueller	1,552	0		17-Dec
Virginia Mugford	1,553	0	0	22-Sep
Kyle Mullins	1,554	0		11-Dec
Andrea Muno	1,555	221	8	1-Oct
Angela Fletcher Munoz	1,556	0		28-Nov
Michal S. Munoz	1,557	0		1-Aug
Carol Murai	1,558	41	7	20-Sep
Junko Muraki	1,559	144	5	10-Nov
James T. Murphy	1,560	0		25-Jul
Jeanie Murphy	1,561	0		30-Aug
Juli Murphy	1,562	335	5	21-Oct
Mary Ellen Murphy	1,563	144	10	10-Jan
Sharon L. Murphy	1,564	388	1	26-Oct
Tracy Murphy	1,565	212	8	3-Oct
Wesley Murphy	1,566	0		4-Jan
Rhiannon Muv	1,567	311	5	26-Oct

## Reforestation Tacoma Must Be Our Highest Priority

<u>Voter/Resident</u>	<u>ID</u>	<u>Page</u>	<u>Line</u>	<u>Date</u>
Jessica Myhre	1,568	0		22-Jul
Cloudine R. Myolim	1,569	208	2	28-Oct
Claire Naccarato	1,570	0		8-Jun
Rosemary Naccarato	1,571	152	6	21-Oct
Yoshi Nakagawa	1,572	0		14-Dec
Dawn Nanfito	1,573	0		30-Nov
Lew Napolitano	1,574	0		8-Aug
Walle Narske	1,575	607	6	3-Aug
Nathan	1,576	0		28-Nov
Brian Nation	1,577	0		22-Jul
Carla E. Nay	1,578	0		25-Nov
Kathlyn Neal	1,579	0		22-Nov
Robert Neal	1,580	119	1	23-Sep
Kristine Nebel	1,581	381	1	29-Oct
Stephen H. Nebel	1,582	389	10	28-Oct
Veta Nebel	1,583	321	6	21-Oct
Natassia Neel	1,584	612	3	3-Aug
Phillip Neel	1,585	0		30-Nov
Ralph Neff	1,586	212	5	5-Oct
Sarah Neighbors	1,587	0		6-Dec
Ben Neil	1,588	311	6	26-Oct
Natasha Nelina	1,589	0		11-Jan
Erica Nelson	1,590	0		7-Dec
Rana H. Nelson	1,591	0		7-Jan
Jules Nemish	1,592	316	5	29-Oct

# Reforestation Tacoma Must Be Our Highest Priority

<u>Voter/Resident</u>	<u>ID</u>	<u>Page</u>	<u>Line</u>	<u>Date</u>
Leon Nettels	1,593	0		22-Jul
Ashley Neufeld	1,594	0		9-Dec
Erin Nevins	1,595	320	5	1-Nov
Zacharias Newman	1,596	0		6-Jun
Laure C. Nichols	1,597	44	4	20-Sep
Alexandria Nickerson	1,598	0		6-Dec
Iver Nitz	1,599	0		27-Nov
Mackenzie Nitz	1,600	0		26-Nov
Laura Nixon	1,601	0		21-Dec
Geerald A. Nobbs	1,602	702	1	3-Aug
Vae Nofoa	1,603	T330	1	7-Sep
Mike Nolan	1,604	325	1	27-Oct
Shannon Noren	1,605	T328	1	7-Sep
Teyanna Noren	1,606	T328	2	7-Sep
Daniel Northcraft	1,607	0		3-Dec
Charmaine Norton	1,608	0		2-Sep
Hannah Norton	1,609	0		29-Nov
Neil Norton	1,610	0		23-Feb
Penny Norton	1,611	0		2-Dec
Alicia Nosworthy	1,612	626	3	3-Aug
Emily Novick	1,613	0		23-Jul
Susan A. Novoa	1,614	0		6-Dec
Bridget Nuno	1,615	0		13-Dec
Susannah Nuriel	1,616	0		27-Nov
Greta Nuse	1,617	654	2	7-Sep

## Reforestation Tacoma Must Be Our Highest Priority

<u>Voter/Resident</u>	<u>ID</u>	<u>Page</u>	<u>Line</u>	<u>Date</u>
Will Nuse	1,618	654	3	7-Sep
Kristofer Nystrom	1,619	0		30-Nov
Ranell Nystrom	1,620	0		30-Nov
Frank C. O'Loughlin	1,621	0		26-Jul
Kelly Lenderink	1,622	A	1	26-Sep
Nolan O'Malley	1,623	314	5	28-Oct
Owen Leslie O'Neal II	1,624	0		6-Jul
Jean O'Loughlin	1,625	0		15-Dec
Jay Oak-Schiller	1,626	0		22-Jul
Katherine C Oak-Schiller	1,627	0		29-Aug
Gen Obata	1,628	0		30-Nov
Ellan Ober	1,629	703	1	3-Aug
Bryan Paolo Obispo	1,630	703	3	3-Aug
Brendan ODonnell	1,631	0		5-Jun
Janice Oien	1,632	0		22-Jun
Ryan Kaoru Okamoto	1,633	0		2-Jan
Lisa Oldoski	1,634	0		29-Nov
Oleksander Lincheek	1,635	173	7	3-Oct
Tony Olenczuk	1,636	0		20-Sep
Alex Oleszco	1,637	169	5	23-Sep
Zackary Oleszco	1,638	170	6	23-Sep
Brandon Oliver	1,639	311	9	26-Oct
Collin Ollman	1,640	191	10	18-Nov
John Oloughlin	1,641	0		19-Dec
Bruce Olsen	1,642	225	2	15-Oct

# Reforestation Tacoma Must Be Our Highest Priority

<u>Voter/Resident</u>	<u>ID</u>	<u>Page</u>	<u>Line</u>	<u>Date</u>
Debra Olsen	1,643	0		22-Jan
Mary C. Olsen	1,644	609	6	3-Aug
Roger Olsen	1,645	609	5	3-Aug
Tim Olsen	1,646	0		7-Jan
Ananda Olson	1,647	0		23-Jul
Christopher Olson	1,648	336	3	21-Oct
Lanae Olson	1,649	0		11-Jan
P Olson	1,650	669	3	7-Sep
Penny Olson	1,651	165	5	23-Sep
Stella Olson	1,652	0		11-Jun
Richard Olszewski	1,653	322	8	21-Oct
Nathalie op de Beeck	1,654	0	0	22-Sep
Zain Orion	1,655	0		21-Nov
Ashley Ormond	1,656	161	4	23-Sep
Ally Orosco	1,657	0		4-Jun
Jessica Orrala	1,658	170	9	23-Sep
Jonathan Orrala	1,659	11	6	11-Sep
Janna Ost	1,660	0		4-Dec
Sarah Ostheller	1,661	0	0	20-Sep
Stephanie Ostmann	1,662	112	10	3-Oct
Mike Otis	1,663	620	5	3-Aug
Nancy Otto	1,664	0		28-Nov
Chenda Ouch	1,665	0		22-Jul
Sharon Ourada	1,666	T328	10	7-Sep
Randall Owens	1,667	0		25-Nov

# Reforestation Tacoma Must Be Our Highest Priority

<u>Voter/Resident</u>	<u>ID</u>	<u>Page</u>	<u>Line</u>	<u>Date</u>
Randall Owyang	1,668	606	3	5-Aug
Noell Pacho	1,669	0		5-Dec
Nannette Page	1,670	651	4	7-Sep
Renee Paine	1,671	0		30-Nov
Dareth Pak	1,672	322	6	21-Oct
Sally Palm-Larson	1,673	111	3	2-Oct
Latasha Palmer	1,674	0		13-Nov
Stan Palmquist	1,675	0	0	20-Sep
Valerie Palumbo	1,676	655	1	7-Sep
Marianne Pan	1,677	0		26-Nov
Andrew Panske	1,678	0		21-Nov
Tony Pantley	1,679	609	8	3-Aug
Alex Papastura	1,680	616	4	3-Aug
Thomas Papastura	1,681	616	3	3-Aug
Mia Paradiso	1,682	0		27-Nov
Christine M. Parent	1,683	166	8	23-Sep
David Parent	1,684	119	4	23-Sep
Neel Parich	1,685	42	6	20-Sep
Karen Parsons	1,686	165	9	23-Sep
Larry S. Parsons	1,687	0		9-Jun
Tricia Parsons	1,688	0		26-Nov
Maria Pascualy	1,689	0		27-Nov
Aife Pasquale	1,690	0		26-Aug
Monique Patel	1,691	0		26-Nov
Dr. Ronald Patterson	1,692	0		8-Jan

## Reforestation Tacoma Must Be Our Highest Priority

<u>Voter/Resident</u>	<u>ID</u>	<u>Page</u>	<u>Line</u>	<u>Date</u>
Ronald Patterson	1,693	0		28-Dec
Catherine Paul	1,694	627	3	3-Aug
Colleen Paul	1,695	0		27-Nov
John Paul	1,696	627	2	3-Aug
Sandra K Paul	1,697	661	3	7-Sep
Tyler Payne	1,698	657	5	7-Sep
Elizabeth Pearson	1,699	0		26-Nov
Marcie Pease	1,700	0		2-Dec
Ginger Peck	1,701	171	3	3-Oct
Lisa Pedersen	1,702	0		28-Nov
Lisa D. Pedersen	1,703	0		1-Jul
Denise Pedrez	1,704	144	7	18-Nov
Kerri Pedrick	1,705	0		3-Jan
Rebecca Peña	1,706	626	5	3-Aug
Yezenia Peña	1,707	632	8	3-Aug
Isaac Pennoyer	1,708	0		10-Nov
Kyle Peppard	1,709	0		29-Nov
Damari Peralez-Long	1,710	0		21-Jun
Tom Perkowitz	1,711	169	7	23-Sep
Susan Perong	1,712	0		24-Jul
Kirsten Peterson	1,713	0		4-Dec
Robin Peterson	1,714	0		25-Nov
Virginia E. Peterson	1,715	0		6-Jul
Clare Petrich	1,716	389	2	28-Oct
Natasha Pettifor	1,717	0		23-Jul

# Reforestation Tacoma Must Be Our Highest Priority

<u>Voter/Resident</u>	<u>ID</u>	<u>Page</u>	<u>Line</u>	<u>Date</u>
Maria Peyer	1,718	616	6	3-Aug
Mark S. Pfeiffer	1,719	0		26-Nov
Andy Pflueger	1,720	0		23-Jul
Nelson Pham	1,721	0		23-Jul
Judit Phelps	1,722	0		6-Jan
Mark Phillips	1,723	0		3-Jun
Theresa Phorns	1,724	627	8	3-Aug
Andrew Pickard	1,725	0	0	22-Sep
Patricia Pickard	1,726	0	0	22-Sep
Michelle A. Pierce	1,727	0		2-Sep
Donna Pierson	1,728	191	7	18-Nov
Barbara Pinckney	1,729	0		25-Jul
Susan Pittman	1,730	41	9	20-Sep
Jeri Pitz	1,731	669	5	7-Sep
Ted Pitz	1,732	669	4	7-Sep
Rick Plasencia	1,733	0		23-Jul
John Platt	1,734	388	9	29-Oct
John Thomas Platt	1,735	0		6-Dec
Mary Elizabeth Platt	1,736	388	10	29-Oct
Jennifer Pledger	1,737	0		23-Jul
James Plourde	1,738	320	3	1-Nov
Christa Plucinski	1,739	0		29-Dec
Debra Pohlenz	1,740	0		18-Dec
Blaine Polhamus	1,741	0		28-Nov
Agata Pomaranska-Lisiecki	1,742	0		9-Jun



# Reforestation Tacoma Must Be Our Highest Priority

<u>Voter/Resident</u>	<u>ID</u>	<u>Page</u>	<u>Line</u>	<u>Date</u>
Sabrina Porteous	1,743	630	8	3-Aug
Erin Potts	1,744	82	6	6-Oct
Steve Potts	1,745	222	5	3-Dec
Theresa Power-Dratis	1,746	B	6	13-Jun
Amelia Powers	1,747	0		2-Jan
Caroline Powers	1,748	0		25-Aug
Holly Powers	1,749	0		23-Jul
Mary Powers	1,750	0		29-Jul
Rosa Powers	1,751	117	4	23-Sep
Beth Prevo	1,752	176	6	29-Oct
Craig Prewitt	1,753	0		27-Aug
Kyle Price	1,754	169	1	23-Sep
Fiona Prince	1,755	0		26-Nov
Angel Prizzle	45	0		17-Nov
Janeen Provazek	1,756	0		2-Jan
Molly Pugh	1,757	608	9	3-Aug
Elizabeth Pules	1,758	607	5	3-Aug
Ann Putnam	1,759	0		3-Jan
Courtney Putnam	1,760	0		2-Jan
Connie Pyles	1,761	0		28-Nov
Emily Queen	1,762	0		22-Jul
Dakota Quill	1,763	655	8	7-Sep
Diane Yorgason Quinn	1,764	112	5	3-Oct
Kayla Quinn	1,765	0		25-Nov
Marcia Quist	1,766	625	4	3-Aug

## Reforestation Tacoma Must Be Our Highest Priority

<u>Voter/Resident</u>	<u>ID</u>	<u>Page</u>	<u>Line</u>	<u>Date</u>
Barbara Racine	1,767	0		11-Nov
Robert Radford	1,768	0		26-Nov
Sally Radford	1,769	0		28-Aug
Lynn Raish	1,770	221	6	1-Oct
Edward L. Raisl	1,771	176	5	29-Oct
Lynn Raist	1,772	176	4	29-Oct
Karen J. Ramage	1,773	0		7-Jul
K. Ramilo	1,774	631	2	3-Aug
Adela Ramos	1,775	83	3	15-Oct
Arron Ramos	1,776	0		24-Jul
Martha Ramos	1,777	0		24-Jul
David Ramsey	1,778	0		8-Jun
Kirsten Randall	1,779	0		12-Jun
Ryan Ransavager	1,780	117	2	23-Sep
Michael Rapson	1,781	706	1	3-Aug
Carol Rasmussen	1,782	111	9	3-Oct
Dan Ratkus	1,783	0		29-Nov
Wendell Ratliff	1,784	315	3	26-Oct
Sarah Ray	1,785	115	5	23-Sep
Elizabeth Raymond	1,786	606	5	5-Aug
Dena Reaugh	1,787	0		26-Nov
Jacob Reber	1,788	0		2-Dec
Angie Reeber	1,789	707	8	3-Aug
Elise Reeber	1,790	705	1	3-Aug
Timothy J. Reeber	1,791	636	4	3-Aug

# Reforestation Tacoma Must Be Our Highest Priority

<u>Voter/Resident</u>	<u>ID</u>	<u>Page</u>	<u>Line</u>	<u>Date</u>
Debi Reed	1,792	0		8-Jan
Frankie Reeder	1,793	0		8-Sep
Abigail Rees	1,794	82	3	5-Oct
Gillian Reese	1,795	327	5	21-Oct
Jaiden Reese	1,796	657	7	7-Sep
Stephen Reese	1,797	212	6	30-Oct
Keonni Reeves	1,798	337	1	21-Oct
Janet E. Regier	1,799	0	0	3-Oct
Joseph Reginhal	1,800	D	3	12-Jul
Molly Reginhal	1,801	D	4	12-Jul
Michelle Reich	1,802	0		30-Nov
Michelle Reid	1,803	0		27-Jun
Tim Reid	1,804	318	5	8-Oct
Bryn Reily	1,805	0		29-Nov
Austin Reimers	1,806	0		30-Nov
Marina Reis	1,807	322	2	21-Oct
Alyssa Reischauer	1,808	657	4	7-Sep
Maria Remick	1,809	0		3-Dec
Maria Remick	1,810	0	0	20-Sep
Jennifer Renner	1,811	0		23-Nov
Matt Renner	1,812	177	0	29-Oct
Susan Repp	1,813	123	7	14-Oct
Georgette Reuter	1,814	0		3-Oct
James Reuter	1,815	123	1	23-Sep
Felix Revelfel	1,816	316	2	30-Oct

## Reforestation Tacoma Must Be Our Highest Priority

<u>Voter/Resident</u>	<u>ID</u>	<u>Page</u>	<u>Line</u>	<u>Date</u>
Pete Reyes	1,817	318	4	8-Nov
Katerina Reynolds	1,818	0		16-Dec
Caridad Rhoades	1,819	111	8	3-Oct
Caridad Rhodes	1,820	609	9	3-Aug
Julie Rhodes	1,821	164	7	23-Sep
Wesley Rhodes	1,822	81	7	30-Sep
Marlene Rholola	1,823	636	10	3-Aug
Jon Rice	1,824	169	4	23-Sep
Kathryn Rice	1,825	630	5	3-Aug
Jaine Richards	1,826	385	4	28-Oct
Ginger Richardson	1,827	0		29-Dec
Elise Richman	1,828	0		26-Nov
Stephanie Riddiford	1,829	0		1-Dec
Lola Ridgley-Wagar	1,830	0		7-Aug
Claudia Riedener	1,831	651	5	7-Sep
Brianna Rindlisbacher	1,832	0		29-Nov
Mary Rink	1,833	0		29-Mar
Selena Elíseo Rios-Grovich	1,834	0		3-Jan
F. Marie Ripley	1,835	615	5	3-Aug
Robert E. Ripley	1,836	615	4	3-Aug
Lynn Charles Riser	1,837	0		30-Nov
Barbara Jo Ritter	1,838	315	10	26-Oct
Sara Roach	1,839	0		23-Nov
Julien Robert	1,840	313	7	27-Oct
Emily Roberts	1,841	387	6	28-Oct

# Reforestation Tacoma Must Be Our Highest Priority

<u>Voter/Resident</u>	<u>ID</u>	<u>Page</u>	<u>Line</u>	<u>Date</u>
Liisa Roberts	1,842	0		21-Nov
Madison Roberts	1,843	610	7	3-Aug
Mark Roberts	1,844	615	1	3-Aug
Mark Roberts	1,845	0		25-Nov
Talce Roberts	1,846	82	9	14-Oct
Chris Robertson	1,847	0		26-Jun
Fairlie Robertson	1,848	0		24-Jul
Katherine Robertson	1,849	170	5	23-Sep
LaDonna Robertson	1,850	0		13-Jun
Beatrice Robinson	1,851	0		26-Nov
Gail Robinson	1,852	0		31-Dec
Holly Robinson	1,853	0		28-Nov
Savannah Robinson	1,854	0		30-Nov
Jasen Robson	1,855	322	3	21-Oct
Diandra Rodriguez	1,856	164	4	23-Sep
Jill Roeder	1,857	0		4-Dec
Michael Rogers	1,858	314	4	27-Oct
Peter J. Rok, Jr.	1,859	169	3	23-Sep
Halle Roland	1,860	0		2-Jul
Patricia Ronald	1,861	620	1	3-Aug
Stephanie Roof	1,862	0		6-Jul
Travis Roof	1,863	0		29-Nov
Diamond Rosi	1,864	211	6	18-Nov
Zoie Rosolek	1,865	0		12-Jun
Sirena Ross	1,866	336	4	21-Oct

# Reforestation Tacoma Must Be Our Highest Priority

<u>Voter/Resident</u>	<u>ID</u>	<u>Page</u>	<u>Line</u>	<u>Date</u>
Steve Ross	1,867	336	5	21-Oct
Dean Rossman	1,868	630	2	3-Aug
L. Rossman	1,869	630	3	3-Aug
Abby Rowlands	1,870	0		22-Jul
Sue Ott Rowlands	1,871	0		22-Jul
Ellison Roycroft	1,872	0		6-Jul
Hinda Rubinstein	1,873	0	0	20-Sep
Allie Rucker	1,874	0		27-Jan
Jean Ruggles	1,875	632	7	3-Aug
Erasmus Ruis	1,876	330	4	23-Feb
Gabriel Ruiz	1,877	701	7	3-Aug
Graham Rumbaugh	1,878	0		27-Nov
Denise Runyan	1,879	636	7	3-Aug
Ruby Russoniello-Damaskos	1,880	0		10-Jul
Kirsti Ruud	1,881	0		22-Nov
Chery Rux	1,882	321	5	21-Oct
Athena Ryan	1,883	667	6	7-Sep
Jeffrey J. Ryan	1,884	401	1	22-Feb
Justin Ryan	1,885	T330	3	7-Sep
Marilyn Ryan	1,886	0		22-Jul
Nina Ryan	1,887	0		29-Nov
Nolan Ryan	1,888	0		12-Jun
Susan Ryan	1,889	0		22-Nov
Michelle Ryder	1,890	0		27-Nov
Andrea Sabad	1,891	707	6	3-Aug

## Reforestation Tacoma Must Be Our Highest Priority

<u>Voter/Resident</u>	<u>ID</u>	<u>Page</u>	<u>Line</u>	<u>Date</u>
Kaylah Sada	1,892	212	2	29-Sep
Lisa Sada	1,893	A	9	1-Nov
Steve Sada	1,894	213	8	19-Nov
Grace Safford	1,895	0		23-Jul
Aubrey Salas	1,896	0		23-Jul
Thomas Salata	1,897	0		28-Nov
Sharice Salazar	1,898	0		11-Dec
Sarah Salvador	1,899	0		29-Nov
Kevin W. Sandin	1,900	0		1-Dec
Gail Sandlin	1,901	222	4	3-Dec
Diane Sandrowski	1,902	0		30-Nov
Liesl SanHaugle	1,903	702	2	3-Aug
Liesl Santkuyll	1,904	321	7	21-Oct
Johnny Saucedo	1,905	320	6	1-Nov
Leslie Saucedo	1,906	0		30-Jun
Lis Saunders	1,907	T329	3	7-Sep
Mariam Savabi	1,908	0		19-Dec
Christine Sayer	1,909	651	2	7-Sep
Natalie Scalf	1,910	0		6-Dec
Sue Scanlon	1,911	162	9	23-Sep
Christy Scerra	1,912	0		3-Jun
Jennifer Schaal	1,913	0		22-Jan
Ashley Schade	1,914	350	1	16-Nov
Gregory Schaefer	1,915	0		19-Sep
Kerry S. Schaefer	1,916	0		8-Feb

## Reforestation Tacoma Must Be Our Highest Priority

<u>Voter/Resident</u>	<u>ID</u>	<u>Page</u>	<u>Line</u>	<u>Date</u>
Susan Schanbacher-Carson	1,917	661	10	7-Sep
Beth Schechner	1,918	123	4	23-Sep
Katie Scherling	1,919	0		24-Aug
Susan Schimling	1,920	0		5-Jun
Shane Schindler	1,921	0		3-Dec
Jennifer Schlatter	1,922	210	6	26-Oct
Clara Schlosser	1,923	618	10	3-Aug
Anthony J. Schmid	1,924	662	6	7-Sep
Deborah Schmid	1,925	42	1	20-Sep
Bruce Schmidt	1,926	153	3	21-Oct
Ann M. Schmoker	1,927	0		26-Nov
Kathrine Schneider	1,928	0		11-Jan
Kyle Schneidmiller	1,929	0		26-Nov
King Schoenfeld	1,930	0		27-Nov
Joel Schomberg	1,931	A3	6	29-Oct
Amanda Schroeder	1,932	0		12-Sep
Christie Schultz	1,933	0		29-Nov
Jacque Schultz	1,934	221	1	30-Sep
Steve Schultz	1,935	618	3	3-Aug
Barret Schulze	1,936	162	7	23-Sep
Carly Schulze	1,937	162	6	23-Sep
Ryan Schutt	1,938	619	9	3-Aug
Marian Schwartz	1,939	669	1	7-Sep
Charity Schweiger	1,940	631	8	3-Aug
Pat Sconlon	1,941	162	10	23-Sep



## Reforestation Tacoma Must Be Our Highest Priority

<u>Voter/Resident</u>	<u>ID</u>	<u>Page</u>	<u>Line</u>	<u>Date</u>
Charles Scott	1,942	610	4	3-Aug
Elizabeth Scott	1,943	385	7	28-Oct
John Scott	1,944	0		1-Dec
Katie Scott	1,945	0		23-Jul
Laura R. K. Scott	1,946	0		16-Dec
Cody Scovel	1,947	0		11-Jun
Martha Scoville	1,948	112	9	3-Oct
Ashley Scribner	1,949	0		2-Dec
David Seago	1,950	0		19-Sep
Malia Seavey	1,951	333	6	21-Oct
Joshua Seele	1,952	321	1	21-Oct
Eric Seibel	1,953	0	0	2-Oct
Karen Seinfeld	1,954	42	9	20-Sep
Sharon Selden	1,955	112	2	3-Oct
Megan Selvage	1,956	0		23-Jul
Amanda Selvam	1,957	0		29-Nov
Anthony Selvam	1,958	0		1-Jul
Schelly Selvar	1,959	0		23-Jul
Anastasia Semenova	1,960	82	1	4-Oct
Cameron Severns	1,961	330	6	23-Feb
Maria Shackles	1,962	608	3	3-Aug
Abby Shade	1,963	0		18-Dec
Shale	1,964	0		23-Nov
Andrew Yamato Shams	1,965	0		5-Jun
Brittany Shands	1,966	0		4-Jul

## Reforestation Tacoma Must Be Our Highest Priority

<u>Voter/Resident</u>	<u>ID</u>	<u>Page</u>	<u>Line</u>	<u>Date</u>
Justin Shands	1,967	0		5-Jul
Nadeem Shariff	1,968	0		23-Jul
Cameron M. Sharp	1,969	0		21-Nov
Diane Shaughnessy	1,970	0		2-Jun
Shannon Sheedlo	1,971	630	7	3-Aug
Roberta Lou Sheetz	1,972	0		12-Nov
Katharine Nora Shelledy	1,973	0		11-Dec
Stephanie Shephard	1,975	0		30-Nov
Jamie Sheppard	1,976	151	6	21-Oct
Steve Sheppard	1,977	151	7	21-Oct
Victor Shergill	1,978	T328	3	7-Sep
Jessica Sherman	1,979	0		18-Nov
Sandy Shettler	1,980	0		8-Sep
Jennifer Shidding	1,981	C	4	13-Jun
Morgan Shields	1,982	0		7-Jul
Audrey Shilander	1,983	0		25-Nov
Jim Shilander	1,984	0		28-Nov
Dylan Shippee	1,985	0		7-Dec
Jacky Sheo Ships	1,974	703	7	3-Aug
Christian Shope	1,986	0		25-Nov
Matt Shrador	1,987	620	3	3-Aug
Patricia Shuman	1,988	0		30-Nov
Anne Shureen	1,989	0		26-Nov
Charlene Shute	1,990	0		2-Jul
Deborah Sidor	1,991	610	1	3-Aug

# Reforestation Tacoma Must Be Our Highest Priority

<u>Voter/Resident</u>	<u>ID</u>	<u>Page</u>	<u>Line</u>	<u>Date</u>
Sandra Sikonia	1,992	115	7	23-Sep
Heather Silva	1,993	151	10	21-Oct
Mario Silva	1,994	151	3	21-Oct
Odis Simmons	1,995	0		6-Dec
Rita Simmons	1,996	324	4	27-Oct
Anneliese Simons	1,997	0		9-Jun
Anneliese Simons	1,998	0	0	23-Sep
Barbara Singer	1,999	627	1	3-Aug
Gina Singh	2,000	0		6-Dec
Carrie Singleton	2,001	161	6	23-Sep
Sarah Singleton-Schroedel	2,002	662	4	7-Sep
Chaney Skadson	2,003	703	2	3-Aug
Alice Skilton	2,004	0		23-Nov
Christopher Skilton	2,005	0		23-Nov
Jordan Skinner	2,006	0		9-Dec
Zak Skold	2,007	999	5	3-Aug
Amanda Skrivanich	2,008	0	0	20-Sep
Amanda Slater	2,009	0		15-Dec
Cooper Sloan	2,010	0		17-Dec
Carol Sloman	2,011	0		29-Nov
Kristin Slotemaker	2,012	0		29-Dec
Michele Slotemaker	2,013	0		28-Dec
Kimberly Smart	2,014	0		13-Jun
Rachel Smeltzer	2,015	0		23-Jul
Elizabeth Smiley	2,016	0		23-Jul

# Reforestation Tacoma Must Be Our Highest Priority

<u>Voter/Resident</u>	<u>ID</u>	<u>Page</u>	<u>Line</u>	<u>Date</u>
Andrea Smith	2,017	0		30-Nov
April Smith	2,018	0		23-Nov
April Smith	2,019	0	0	20-Sep
Carol Rae Smith	2,020	112	1	3-Oct
Dawn Smith	2,021	4	8	4-Sep
Emerson Smith	2,022	0		25-Apr
Fran Smith	2,023	386	2	28-Oct
Henry Smith	2,024	T330	5	7-Sep
Ingrid Smith	2,025	317	7	31-Oct
Jaala Smith	2,026	0		23-Jul
Jennifer Smith	2,027	221	4	30-Sep
Jessica Smith	2,028	0		23-Jul
Kristen Smith	2,029	192	2	23-Sep
Linda Smith	2,030	222	2	3-Dec
Mark L. Smith	2,031	627	9	3-Aug
Michael L. Smith	2,032	4	9	8-Sep
Monty Smith	2,033	0		1-Dec
Sabrina Smith	2,034	619	2	3-Aug
Timothy Smith	2,035	619	1	3-Aug
Yasmin Smith	2,036	0		29-Nov
Jace Snedecor	2,037	628	9	3-Aug
Jennifer Snelking	2,038	330	7	23-Feb
Jonathan Snow	2,039	0		15-Jun
Lisa M. Snyder	2,040	0		18-Dec
Marian Snyder	2,041	0		16-Dec

# Reforestation Tacoma Must Be Our Highest Priority

<u>Voter/Resident</u>	<u>ID</u>	<u>Page</u>	<u>Line</u>	<u>Date</u>
Antonio Solano	2,042	0		28-Jul
Cheri Solien	2,043	T331	4	7-Sep
Chelsea Sommer	2,044	0		2-Dec
Lisha Song	2,045	0		15-Dec
Jennifer Sonju	2,046	336	9	21-Oct
Karen Sonju	2,047	336	10	21-Oct
Janet Sorensen	2,048	325	6	27-Oct
Kelsey Sowell	2,049	0		2-Jul
Liane Spealich	2,050	A3	2	9-Oct
Danielle Spencer	2,051	629	2	3-Aug
Spirit	2,052	0		20-Nov
Jessica Spring	2,053	0		30-Nov
Theresa Spuck	2,054	388	7	28-Oct
Lynda Squally	2,055	0		1-Aug
Emily Squyres	2,056	0		25-Nov
Gwynne Calla Squyres	2,057	0		25-Nov
Tori St. Com	2,058	617	9	3-Aug
Erik St. Gray	2,059	118	6	23-Sep
Wren St. Gray	2,060	0		2-Jun
Arch St. Helen	2,061	B	10	13-Jun
Elaine M. Stafford	2,062	0		19-Sep
Simone Staley	2,063	0		26-Aug
Eden Standley	2,064	0		25-Nov
Madalyn Standley	2,065	0		25-Nov
Neil J. Standley	2,066	0		25-Nov

# Reforestation Tacoma Must Be Our Highest Priority

<u>Voter/Resident</u>	<u>ID</u>	<u>Page</u>	<u>Line</u>	<u>Date</u>
Mindy Stang	2,067	631	3	3-Aug
Vicky Stanich	2,068	329	1	23-Feb
Victoria Stanich	2,069	0		6-Jul
Chris Stanislawski	2,070	225	5	17-Oct
Connie Stanzak	2,071	0		1-Jul
Autumn Star	2,072	0		20-Jan
Amanda Starnes	2,073	213	5	18-Nov
Jonathan Staub	2,074	0		26-Nov
Brad Stauch	2,075	11	7	11-Sep
Chris Staudinger	2,076	164	6	23-Sep
Alex Steele	2,077	209	5	28-Oct
Amanda Steele	2,078	0		23-Jul
Mary H. Steenson	2,079	222	3	3-Dec
Dianne Stefanko	2,080	0		24-Nov
Garret Steider	2,081	609	4	3-Aug
Steven Steinway	2,082	0		26-Nov
Heidi Stephens	2,083	0		20-Nov
Laurie Sterling	2,084	115	10	23-Sep
Austin Stern	2,085	0		5-Dec
Gregory Stevens	2,086	162	4	23-Sep
Lorna Stevens	2,087	161	10	23-Sep
Michael S. Stevens	2,088	630	6	3-Aug
Russell Stevens	2,089	213	9	19-Nov
Holly Stewart	2,090	387	2	28-Oct
Janet Stewart	2,091	0		25-Nov

## Reforestation Tacoma Must Be Our Highest Priority

<u>Voter/Resident</u>	<u>ID</u>	<u>Page</u>	<u>Line</u>	<u>Date</u>
Jessie Stewart	2,092	0		1-Jul
Willie Stewart	2,093	385	2	28-Oct
Julee Ann Stilwell	2,094	0		29-Dec
Emily Stinnett	2,095	0		26-Nov
Rebecca Stith	2,096	0		23-Jul
Sisy Stivers	2,097	0		4-Jul
Rebecca S. Stocker	2,098	0		23-Nov
Barbara L. Stockstad	2,099	253	2	2-Nov
Elliott Stockstad	2,100	A3	5	29-Oct
Heidi Stoermer	2,101	628	5	3-Aug
Halcyon Stoker-Graham	2,102	0		30-Nov
Phoenix Stoker-Graham	2,103	161	9	23-Sep
Jennifer Stone	2,104	316	8	30-Oct
Jessica Stone	2,105	166	10	23-Sep
Matt Stone	2,106	316	9	30-Oct
Lynn Stopher	2,107	0		29-Nov
Gail L. Storrs	2,108	4	10	12-Sep
Jessica D. Stovall	2,109	0		24-Jul
John Reagan Stovall	2,110	0		23-Jul
Josh Stovall	2,111	253	10	6-Nov
Lindsey Stover	2,112	0		5-Dec
Sara Stowitts	2,113	0		14-Jun
Heather Straub	2,114	0		20-Nov
Heather Rogers Straub	2,115	1	8	24-Aug
Glen Strecker	2,116	317	8	31-Oct

## Reforestation Tacoma Must Be Our Highest Priority

<u>Voter/Resident</u>	<u>ID</u>	<u>Page</u>	<u>Line</u>	<u>Date</u>
Tim Strege	2,117	0		9-Jun
Stella Streufert	2,118	0		30-Nov
Courtney Strickland	2,119	707	3	3-Aug
John Strobel	2,120	0		16-Dec
Mary Jo Strom Copland	2,121	0		9-Jun
Sandra Strong	2,122	0		30-Nov
Becky Stroud	2,123	801	4	3-Aug
Greg Stroud	2,124	162	8	23-Sep
Leslie Stroud-Romeo	2,125	162	5	23-Sep
Brenna Stroup	2,126	0		25-Nov
Noah Struthers	2,127	170	2	23-Sep
Christopher Stubel	2,128	0		27-Jul
Laura Stuhr	2,129	335	6	21-Oct
Karen K. Sudderth	2,130	620	8	3-Aug
Jill Sullivan	2,131	329	9	22-Feb
Julie Sullivan	2,132	176	10	29-Oct
Mary Ellen Sullivan	2,133	629	4	3-Aug
Michael Sullivan	2,134	3	1	24-Aug
Sean Sullivan	2,135	329	8	22-Feb
Friday J. Sutherland	2,136	0		26-Nov
Derrick Swansey	2,137	163	3	23-Sep
Karen Swanson	2,138	0		30-Nov
Rachel Swanson	2,139	317	5	31-Oct
Sally Swanson	2,140	253	7	6-Nov
Kate Swarner	2,141	0		26-Nov



# Reforestation Tacoma Must Be Our Highest Priority

<u>Voter/Resident</u>	<u>ID</u>	<u>Page</u>	<u>Line</u>	<u>Date</u>
Amanda Swarr	2,142	0		28-Nov
Shannon Swayze	2,143	0		29-Nov
Clare Sweeney	2,144	0		5-Dec
Ian Swenson	2,145	0		1-Dec
Joseph Swiercek	2,146	0		11-Jun
Caroline Swinehart	2,147	0		5-Jun
Vallary Swington-Marsalis	2,148	0	0	20-Sep
Ross Syfond	2,149	42	3	20-Sep
K T	2,150	0		29-Nov
Eric Taber	2,151	0		29-Nov
Lauren Taber	2,152	0		16-Dec
Thomas Tague	2,153	0		3-Jul
Karen Takacs	2,154	0		22-Jun
Jess Taluth	2,155	0		27-Nov
Merilee Tanbara	2,156	608	8	3-Aug
Andrea Taskey	2,157	0		12-Jun
Olivia Tate	2,158	0		31-Aug
Anthony Tauriainen	2,159	0		20-Nov
Nick Tauriainen	2,160	163	1	23-Sep
Andrew Taylor	2,161	0		12-Jun
Austin Taylor	2,162	0		23-Jul
Bree Taylor	2,163	0		29-Nov
Joseph Taylor	2,164	0		10-Apr
Nicholas Taylor	2,165	0		22-Jul
Onica I. Taylor	2,166	0		16-Jul

## Reforestation Tacoma Must Be Our Highest Priority

<u>Voter/Resident</u>	<u>ID</u>	<u>Page</u>	<u>Line</u>	<u>Date</u>
William Terraye	2,167	321	3	21-Oct
Annette Tessier	2,168	611	4	3-Aug
Joy Tevis	2,169	608	7	3-Aug
Tracie Thacker	2,170	0		4-Jul
Dan Therrien	2,171	619	6	3-Aug
Parker Therrien	2,172	619	7	3-Aug
Stacey Therrien	2,173	619	5	3-Aug
Janet Thessen	2,174	330	9	23-Feb
Melissa Thibodeau	2,175	0		23-Jul
Katrina A. Thietje-Weihs	2,176	0		8-Jul
Jim Thoburn	2,177	152	3	21-Oct
Kassandra Lynne Thomas	2,178	0		29-Nov
Mary Beth Thomas	2,179	0		23-Nov
Alisun Thompson	2,180	0		8-Jun
Christina Thompson	2,181	321	4	21-Oct
Donna Thompson	2,182	0		25-Nov
Jeremy Thompson	2,183	612	9	3-Aug
JoElle Thompson	2,184	0		12-Jun
Mike Thompson	2,185	621	5	3-Aug
Samantha Thompson	2,186	0		31-Jul
Rob Thoms	2,187	654	8	7-Sep
Rachel Thomson	2,188	0		24-Nov
Hannah Thornton	2,189	0		13-Nov
Janet Thorpe	2,190	384	3	29-Oct
Jerry Thorpe	2,191	0		11-Aug

# Reforestation Tacoma Must Be Our Highest Priority

<u>Voter/Resident</u>	<u>ID</u>	<u>Page</u>	<u>Line</u>	<u>Date</u>
Collin Thrower	2,192	116	1	23-Sep
Emily Thuma	2,193	0		2-Dec
Jennifer Thut	2,194	191	5	18-Nov
Trinity Tiedeman	2,195	0		19-Aug
Joseph Tieger	2,196	11	8	11-Sep
Joseph Tiepen	2,197	163	6	23-Sep
Diane Tilstra	2,198	0		25-Nov
Amber Timboe	2,199	0		23-Jul
Katherine Tiric	2,200	0		15-Dec
Laurel Titland	2,201	0		28-Nov
Katie Titus	2,202	0		30-Nov
Sarah Titus	2,203	0		25-Nov
Terri Tobey	2,204	0		3-Jan
Emily Toffol	2,205	335	10	21-Oct
Karen Tofte	2,206	651	1	7-Sep
Mark Toleind	2,207	B	3	12-Jun
Zachary Toliver	2,208	313	1	27-Oct
Zachary Ryan Toliver	2,209	0		13-Dec
Kristin Tollefson	2,210	657	10	7-Sep
Sheri Tonn	2,211	0		27-Nov
Cecilia Topete	2,212	0		23-Jul
Alexandra Torres	2,213	0		16-Dec
Alicia Torrez	2,214	313	6	27-Oct
Kim Tosch	2,215	0		23-Jul
Cormon Toupin	2,216	333	1	21-Oct

# Reforestation Tacoma Must Be Our Highest Priority

<u>Voter/Resident</u>	<u>ID</u>	<u>Page</u>	<u>Line</u>	<u>Date</u>
Max Townsend	2,217	0		26-Jun
Anna Trammel	2,218	164	3	23-Sep
Kenneth Tran	2,219	0		8-Sep
Pamela N. Transue	2,220	42	7	20-Sep
Andrew Treece	2,221	311	10	26-Oct
Lauren Trevino	2,222	318	1	1-Nov
Stephenie Troftgruben	2,223	0		25-Nov
Stena Troyer	2,224	336	6	21-Oct
Mallory Trudell	2,225	0		11-Jun
Steph Trudell	2,226	0		11-Jun
Chaun-Chaun Tsai	363	A3	1	29-Sep
Richard Tucker	2,227	324	2	27-Oct
Ashlie Tuhkanen	2,228	0		30-Nov
Ed Tuhkanen	2,229	0		29-Nov
Kirsten Tureno	2,230	0		7-Dec
Doug Turner	2,231	0		6-Jul
Jay Turner	2,232	1	7	24-Aug
Jerry Turner	2,233	4	2	28-Aug
Julie S. Turner	2,234	1	6	24-Aug
Mechelle Turner	2,235	608	1	3-Aug
N. Turner	2,236	0		7-Jun
Samantha Turner	2,237	4	3	29-Aug
Susan L. Turner	2,238	4	4	30-Aug
Dawn Turnipseed	2,239	0		2-Sep
James R. Tuttle	2,240	0		20-Nov

## Reforestation Tacoma Must Be Our Highest Priority

<u>Voter/Resident</u>	<u>ID</u>	<u>Page</u>	<u>Line</u>	<u>Date</u>
Ruth Tweeter	2,241	1	10	24-Aug
Ryanne Tyler	2,242	0		12-Jun
Mehmet Uluer	2,243	0		26-Nov
Fredericka Umstead	2,244	617	1	3-Aug
Kim Underwood	2,245	0		26-Nov
Taylor Underwood	2,246	0		26-Nov
Eva Urena	2,247	631	10	3-Aug
Joey Urquhart	2,248	703	9	3-Aug
Cathie Urwin	2,249	0		27-Nov
Rebeka Vairapandi	2,250	0		11-Dec
Samantha Vale	2,251	0		23-Jul
Abigail Valencia	2,252	0		23-Jul
Destiny Valencia	2,253	0		12-Jun
Gia Valentine	2,254	0		3-Dec
Kerry Valentine	2,255	0		8-Jun
Lissa Valentine	2,256	176	8	29-Oct
Monica Valentine	2,257	165	7	23-Sep
Aaron Valla	2,258	335	7	21-Oct
Heather Valtee	2,259	322	10	21-Oct
Luke Vammice	2,260	209	4	28-Oct
Joshua Van Dyk	586	0		13-Jun
Ryan VanBaalen	2,261	0		25-Nov
David Vance	2,262	123	8	14-Oct
Jessica VanCleaf	2,263	0	0	23-Sep
Jan Vandervort	2,264	0		23-Jul

## Reforestation Tacoma Must Be Our Highest Priority

<u>Voter/Resident</u>	<u>ID</u>	<u>Page</u>	<u>Line</u>	<u>Date</u>
Ruth Varkovitzky	2,265	0		1-Jul
Tyler Vassar	2,266	0		8-Sep
Isabel Vassiliadis	2,267	0		30-Jul
Ann Vaughn	2,268	654	6	7-Sep
Chris Vaughn	2,269	657	6	7-Sep
Mike Vaughn	2,270	654	7	7-Sep
Cynthia Vazquez	2,271	0		2-Dec
Ivan Vazquez	2,272	0		2-Dec
David Veeck	2,273	0	0	22-Sep
Julie Veeck	2,274	0	0	22-Sep
Bryan Veentjer	2,275	702	8	3-Aug
Timothy Veja	2,276	337	7	21-Oct
Sierra Venes	2,277	336	2	21-Oct
Janice Verburg	2,278	41	6	20-Sep
Anna Vermaire	2,279	0		29-Mar
Jane VerValin	2,280	0		3-Dec
Shannon Vest	2,281	0		29-Nov
Yasmin Vian	2,282	0		24-Nov
Ausci Viera	2,283	634	2	3-Aug
Jorge Villamil	2,284	T331	1	7-Sep
Elias Villanreal	2,285	625	3	3-Aug
Lisa D. Villegas	2,286	253	9	6-Nov
Sandra Villegas	2,287	0		22-Jul
C. E. "Chip" Vincent	2,288	0		30-Nov
Joseph Viacci Vincent	2,289	164	9	23-Sep

## Reforestation Tacoma Must Be Our Highest Priority

<u>Voter/Resident</u>	<u>ID</u>	<u>Page</u>	<u>Line</u>	<u>Date</u>
Monnica Vincent	2,290	0		27-Nov
Cecelia Vu	2,291	702	9	3-Aug
Anabelle W	2,292	0		29-Nov
Neal Wade	2,293	B	2	10-Jun
Wendy Wahman	2,294	0		24-Jul
Kate Waind	2,295	213	10	19-Nov
Reina Wakefield	2,296	312	2	23-Oct
Jodi Walker	2,297	111	5	2-Oct
Lindsay Walker	2,298	0		1-Dec
Jennifer Walkley	2,299	659	6	7-Sep
Ted Walkley	2,300	655	10	7-Sep
Evan Wallace	2,301	312	6	23-Oct
Nadine Wallace	2,302	632	6	3-Aug
Derek Walsh	2,303	619	8	3-Aug
Erica Walsh	2,304	619	10	3-Aug
Jeanne Waltep	2,305	124	4	14-Oct
Lonnie Walter	2,306	707	2	3-Aug
Art Wang	2,307	112	6	3-Oct
Arlene Warden	2,308	0		30-Nov
Sally Warden	2,309	0		20-Nov
Robert Anton Warfield	2,310	0		26-Nov
Lindsey Warr	2,311	0		20-Nov
Alecia R. Warren	2,312	385	8	28-Oct
Henry Warren	2,313	311	8	26-Oct
Liz Wasson	2,314	329	6	22-Feb

## Reforestation Tacoma Must Be Our Highest Priority

<u>Voter/Resident</u>	<u>ID</u>	<u>Page</u>	<u>Line</u>	<u>Date</u>
Adam Waters	2,315	313	4	27-Oct
Marietta Watson	2,316	0		1-Dec
Debra Watt	2,317	620	4	3-Aug
Joseph Watts	2,318	312	8	23-Oct
Dorothy Wayne	2,319	0		11-Nov
Marty Webb	2,320	3	3	24-Aug
Michael Webb	2,321	177	4	7-Jun
Kathryn Weber	2,322	0		30-Nov
James P. Webster	2,323	11	4	11-Sep
Dawn M. Webster Williams	2,324	0		2-Sep
Erin Wegner	2,325	0		23-Jul
Erin Wehman	2,326	0		25-Nov
Anne Weigle	2,327	0		2-Dec
Amanda Weinper	2,328	0		28-Nov
Madeleine Weintem	2,329	314	10	28-Oct
Ben Welch	2,330	0		29-Nov
Leanne Welch	2,331	0	0	20-Sep
Barbara Wellman	2,332	0		5-Jan
Elaine Wellman	2,333	0		9-Dec
Jeff Wells	2,334	705	7	3-Aug
Wendy Wells	2,335	705	8	3-Aug
Shawn Welsh	2,336	629	1	3-Aug
Ann Welton	2,337	0	0	20-Sep
Jane Wendel	2,338	707	5	3-Aug
Bever Wengard	2,339	612	10	3-Aug



## Reforestation Tacoma Must Be Our Highest Priority

<u>Voter/Resident</u>	<u>ID</u>	<u>Page</u>	<u>Line</u>	<u>Date</u>
Kelly Wengard	2,340	609	10	3-Aug
Robert Wengrod	2,341	324	3	27-Oct
Sharon M. West	2,342	0		1-Jul
Phil Westberg	2,343	667	7	7-Sep
Pete Weymiller	2,344	0		4-Dec
Carol Weymouth	2,345	0		26-Jun
Tharesa Wheaton	2,346	177	1	7-Jun
Jen Wheeler	2,347	0		17-Dec
Kathy Wheeler	2,348	0		12-Jun
Michele Wheeler	2,349	0		23-Jul
Nathaniel Wherton	2,350	169	10	23-Sep
James Whey	2,351	191	8	18-Nov
Kathy Whisler	2,352	654	10	7-Sep
Russell Whitaker	2,353	325	5	27-Oct
Steven Whitcher	2,354	0		14-Aug
Areatha White	2,355	0		27-Nov
Carolina White	2,356	636	3	3-Aug
Cele White	2,357	350	2	16-Nov
Giavonna White	2,358	0		28-Jul
Gloria White	2,359	0		28-Jul
Heather White	2,360	0		27-Nov
Kelsey White	2,361	620	7	3-Aug
Maura White	2,362	0		29-Jan
Barbara Whitehart	2,363	0		8-Jan
Laura Whitehill	2,364	0		27-Aug

## Reforestation Tacoma Must Be Our Highest Priority

<u>Voter/Resident</u>	<u>ID</u>	<u>Page</u>	<u>Line</u>	<u>Date</u>
John Whiteman	2,365	173	3	3-Oct
Lynn Whitener	2,366	606	1	5-Aug
Clara Whitmarsh	2,367	386	6	28-Oct
Drew Whitney	2,368	0		17-Nov
Janet R. Whitney	2,369	165	2	23-Sep
Ryan James Wicklund	2,370	0		4-Dec
Audrey Widner	2,371	318	2	1-Nov
Bill Wiens	2,372	0	0	22-Sep
William Wiens	2,373	0		31-Jul
Scott Wild	2,374	0		30-Nov
Jordan Wilde	2,375	313	9	27-Oct
Madison Wilde	2,376	313	8	27-Oct
Shelley Wilkinson	2,377	0		7-Dec
Neiko Will	2,378	628	3	3-Aug
Suzy Willhoft	2,379	0		25-Nov
Barbara Williams	2,380	0	0	21-Sep
Caitlin Williams	2,381	0		23-Jul
Dr. James H. Williams	2,382	0		15-Dec
Jeremy Williams	2,383	0		22-Jul
Marsha Williams	2,384	112	3	3-Oct
Steve Williams	2,385	0	0	20-Sep
Tamara Reed Williams	2,386	0		21-Nov
Tenisha Williams	2,387	209	9	28-Oct
Valerie Williams	2,388	0		23-Jul
Debra Williams-Applete	2,389	41	2	20-Sep

## Reforestation Tacoma Must Be Our Highest Priority

<u>Voter/Resident</u>	<u>ID</u>	<u>Page</u>	<u>Line</u>	<u>Date</u>
Jamie Williams.	2,390	0		14-Dec
Brendan Williamson	2,391	0		14-Dec
Sophia Williamson	2,392	0		29-Nov
Deborah Wilson	2,393	A3	3	9-Oct
Donovon Wilson	2,394	A3	4	28-Oct
L:eah Wilson	2,395	0		27-Nov
Nicole Wilson	2,396	314	3	27-Oct
Thomas Wilson	2,397	0		23-Jul
Teresa Windrem	2,398	621	7	3-Aug
Teresa R Windrom	2,399	120	2	27-Sep
Aubri Wing	2,400	657	2	7-Sep
Aubri Wing	2,401	0		29-Nov
Donald Joel Wingard	2,402	0		5-Dec
Lucinda Wingard	2,403	0		2-Jan
Sarah Winnett	2,404	0		24-Nov
Eleanor Winterfeldt	2,405	0		24-Jan
Teri Wiseman-Kuhlman	2,406	113	1	3-Oct
Christina Withey	2,407	0		19-Dec
Destry Witt	2,408	0		25-Nov
Brian Witte	2,409	0		7-Jul
Laura Wittmann	2,410	659	10	7-Sep
Anitra Wolf	2,411	213	6	18-Nov
Greg Wolf	2,412	634	3	3-Aug
Paulette Wolf	2,413	999	4	3-Aug
Keshet Cohen	2,414	322	1	1-Nov

## Reforestation Tacoma Must Be Our Highest Priority

<u>Voter/Resident</u>	<u>ID</u>	<u>Page</u>	<u>Line</u>	<u>Date</u>
Khristine Wolfe	2,415	629	5	3-Aug
Susan Wolfe	2,416	629	6	3-Aug
Daniel Jacob Flores Wolfert	681	0		17-Jan
Carolyn Wolkenweber	2,417	165	6	23-Sep
Shayna Wood	2,418	0		7-Nov
W. Preston Woodall Jr	2,419	662	1	7-Sep
Caroline Mary Woodhams	2,420	0		22-Feb
Emily Woodward	2,421	0		30-Nov
Eric Woodward	2,422	701	9	3-Aug
David Woodworth	2,423	706	5	3-Aug
Derek Woodworth	2,424	606	6	5-Aug
Serenity Wren	2,425	0		24-Jul
Linnaea Wright	2,426	0		23-Jul
Susan Wright	2,427	152	1	21-Oct
Wendy Wright	2,428	0		2-Jun
Laura Wulf	2,429	629	9	3-Aug
Lowell Wyse	2,430	169	8	23-Sep
Stephen Xu	2,431	705	3	3-Aug
Tiffany Y'vonne	2,432	0		24-Nov
Michael Yadrick	2,433	123	2	23-Sep
Aliza Yair	2,434	0		4-Dec
Justin Yee	2,435	312	4	23-Oct
August Yoder	2,436	610	10	3-Aug
Bob Young	2,437	116	3	23-Sep
Charissa Young	2,438	0		8-Mar

# Reforestation Tacoma Must Be Our Highest Priority

<u>Voter/Resident</u>	<u>ID</u>	<u>Page</u>	<u>Line</u>	<u>Date</u>
Gregory Youtz	2,439	0	0	22-Sep
Michaëlle J. Zacharczyk	2,440	0		4-Jan
Megan Zahringer	2,441	0		3-Jun
Bonnee K. Zander	2,442	0	0	22-Sep
Natalia Zarelli	2,443	0		23-Jul
Michaela Zaro	2,444	627	6	3-Aug
Hillary Zegzula	2,445	704	9	3-Aug
Alexandra Zepeda	2,446	0		1-Sep
Griffen Zetterberg	2,447	314	6	28-Oct
Lucy Zhou	2,448	41	4	20-Sep
Mei Zhu	2,449	0		22-Jul
Jessica Zinchak	2,450	173	6	3-Oct
Kenneth Zirinsky	2,451	0	0	20-Sep
Chelsey Zurfluh	2,452	123	3	23-Sep
Evan Zynda	2,453	314	7	28-Oct
Jill Zyvoloski	2,454	0		3-Dec

**From:** Georgette Reuter <gee.reuter@gmail.com>  
**Sent:** Monday, September 23, 2024 4:36 PM  
**To:** City Clerk's Office  
**Subject:** Sending My Support for the Home in Tacoma's Landscaping Code

To Tacoma City Mayor Woodards and Tacoma City Council Members,

My husband and I **fully support** the Tacoma Planning Commission's current recommendations for the Home in Tacoma Phase 2 **Landscaping Code**. We firmly believe that it is essential to include the Landscaping Code within the HiT package in order to provide the necessary protection of our mature trees and also the planting of thousands of more new trees on private property.

**We also strongly support the City of Tacoma's goal of increasing our 20% tree canopy to 30% by 2030.** There are 2 main steps to be taken in order to accomplish this worthy goal. The first step was taken by the December 2023 passage of the TMC Tree Ordinance 9.20 that will help to protect and expand Tacoma's public right-of-way trees. And currently, we have the opportunity to take the second step - which is to protect and expand our tree canopy on private property - by including the Planning Commission's recommendations (amendments) for the Landscaping Code.

As lifelong residents of Tacoma, we have enjoyed living in our home for over 50 years. Unfortunately, during those years, we have witnessed **the slow decline of our City's tree canopy** - not only witnessing the neglect of the health of our right-of-way street trees, but also the needless removal of mature trees on private property. Add to this, we all have witnessed the planting of new trees that slowly die because of lack of watering! At this rate, without strong regulations in place, we will continue to see our already low 20% tree canopy continue to sadly decline.

Too much is at stake to continue to ignore the essential importance of Tacoma's Urban Forest. Climate Change is real and the effects of it are already happening. The future health and well being of our residents is at risk if we don't act immediately. **We can and we must have BOTH: Housing and tree canopy!**

We cannot and should not ignore all of the current research that proves the environmental and financial benefits provided by a healthy urban forest. Trees are our **green infrastructure** and should be well maintained just as we do our grey infrastructure

**Now** is the time for our City leaders to act to preserve, protect and expand our valuable urban forest.

Sincerely,  
Georgette and Jim Reuter  
2201 North Union Avenue  
Tacoma

**From:** Nina Rook <nina.rook@gmail.com>  
**Sent:** Monday, September 23, 2024 4:46 PM  
**To:** City Clerk's Office  
**Subject:** Don't do irreparable damage to our beautiful city

Please pause.

Our city has been forward thinking in focussing on Missing Middle housing, but what is being considered at this point is a step too far. Take the outcomes possible for a lot like mine, just over 6,000 sq ft. Depending on UR, it could host 4 units with a height of 35 ft and 15 foot setbacks, or 16 units in a 5 storey building with 2.5 ft setbacks. If the latter seems to have minimal space for trees, there's a fee you can pay. Given the relative cost of housing units and tree fees, I suspect people are going to choose to build the latter.

Jane Jacobs' "Death and Life of Great American Cities" is startlingly current 60+ years after publication. For a street to work for all its users, it needs spaces for interaction, sightlines for people to provide useful eyes on the street, trees to provide shade and lower temperatures -- as well as some variety in uses. Looking at the examples we have already seen in Tacoma of tree-less, zero setback housing, we must take the time to ensure that we don't create zombie zones that satisfy nothing but a deadline -- a deadline which was established before the complexities of state-wide regulation came into the mix. It might even give us chance to revisit the proposed inequities of covenanted properties. . .

Thank you for your consideration,

Nina Rook

206.795.7773 (Mobile)

**From:** Martin Bennett <martinsamuelbennett@gmail.com>  
**Sent:** Monday, September 23, 2024 4:39 PM  
**To:** City Clerk's Office  
**Subject:** Written Comments for the 24 SEP Home in Tacoma Public Hearing

Good Evening,

After reviewing the proposed zoning changes for the Home in Tacoma, I have several major concerns on the effect this change will have on our neighborhoods.

1. Inadequate parking requirements - the updates to UR-2 and 3 (which will encompass most of the city) do not require ANY parking for developers if they are within 1/2 mile of a public transit corridor. To use UR-2 as an example, a developer would be able to put between 6 and 12 units on a 6,000 sf lot and not have ANY spots allocated for those residents. This is ludicrous. Do you think that anyone who lives in modern America can live their lives just because they're within 1/2 mile of a BRT stop? I would challenge you actually research the number of Tacoma residents who do all of their business through public transit. What this will do is clog the neighborhoods with the 6-12+ extra cars, making parking more difficult for all the rest of us, as well as doing a disservice to those residents who will also have a hard time finding parking.

This reeks of a zoning change drawn up by a developer who doesn't have to deal with the ramifications of their actions. They get to pocket the extra money by developing that lot to the maximum extent possible while not caring about the livability of the neighborhoods they alter. It is disgusting, and a very sad attempt to cover up blatant self-dealing with an appeal to 'public transit'.

2. Setbacks - Again, using the UR-2 as an example, under the 'bonus' 2 example, the minimum required setback would be 5 ft from the lot line. How is that going to leave any room for a tree canopy? The short answer is, it won't. And again, the reason for this would appear to be the same as my parking concern. By maximizing the buildable area of a lot, you can cram more units in the same space.

Looking to the amazing work the Tacoma Tree Foundation has been doing to increase tree cover and reduce average surface temperatures, it seems we are fighting ourselves by allowing developers to create more concrete centric spaces.

Please review these for the meeting, as I will be attending to make a statement.

Best regards,

Martin Bennett



**From:** Esther Day <Dayesther214@outlook.com>  
**Sent:** Monday, September 23, 2024 4:49 PM  
**To:** Woodards, Victoria; Rumbaugh, Sarah; Bushnell, Joe; Hines, John; Scott, Jamika; Daniels, Kiara; Sadalge, Sandesh; Diaz, Olgy; Walker, Kristina  
**Cc:** Pauli, Elizabeth; City Clerk's Office  
**Subject:** DROP HOME IN TACOMA AND WORK WITH HOUSE BILL 1110  
**Attachments:** First Post Card 1..docx; HIT 2 CARD SENT.docx; MRSC April 2022.pdf; Good evening.docx

Dear Mayor, City Council, City Manager, and City Clerk,

Tacoma must stop the process of Home In Tacoma as it has failed to reach all it's citizens. Not only were postcards sent out announcing Home In Tacoma but they did not have personal addresses – they were addressed to Postal Customer. Those postcards don't have to be delivered AND WERE NOT DELIVERED by some carriers.

One postcard was mailed in 2021 during the Pandemic – to postal customer. Really? During a time that folks were worried about their jobs, homes, rents, school, and so much more Tacoma did not see fit to send to their respective homes so that they would stop to read those post cards.

Here is one of the last postcards I saw, but did not receive because only 3 homes in our neighborhood got them out of 90,000 cards that had been sent out by the City – according to a reliable source.

I am attaching copies of those postcards so that you see what I am saying.

I am also attaching a copy of the MRSC Newsletter that I will address tomorrow at the hearing. Read the last paragraph of the first page and the subsequent info in the second page. About the Fiduciary Responsibility that Transit Board members have to vote for whatever Transit needs.

**I am here to tell you, not just NO, but hell NO. If you can't see that you have a fiduciary responsibility to the VOTERS, not to Transit that is ANOTHER COMPANY!!! Then you need to get off the council now.**

Here is my speech for tomorrow.

Let HB 1110 Stand. The rezoning you are doing is too much and is destroying neighborhoods already and it will get worse.

We need Homeownership Opportunities. Not nooses around people's necks. THAT IS WHAT YOU ARE DOING WITH HOME IN TACOMA.

Given that over half of Tacoma is unaware of this rezoning – it is Taxation without Representation. STOP HIT NOW! KEEP HB1110.

Respectfully,  
Esther Day  
A Past Planning Commissioner

FIRST POST CARD – SENT DURING THE PANDEMIC and did not tell people their neighborhoods were being rezoned. To this day, A LOT of Tacoma does not know this. The cards talk cutesy stuff that does not call attention.

**PUBLIC HEARING NOTICE**

Today many people struggle to find housing they can afford that meets their needs. The City is asking for public comment on proposals that would affect most of Tacoma's residential areas, as well as a package of near-term code changes, and an environmental (SEPA) review of potential growth impacts.

**To provide comments:**

- Join us at 5:30 p.m. on **Wednesday, April 7, 2021** at the Planning Commission Public Hearing on 200M
- Provide written comments to [planning@cityoftacoma.org](mailto:planning@cityoftacoma.org) or the address below by **Friday, April 9, 2021**:  
Planning Commission  
747 Market Street Room 349, Tacoma WA 98402
- Provide comments on our interactive online map by **Friday, April 9, 2021**

Meeting details are available at [cityoftacoma.org/homeintacoma](http://cityoftacoma.org/homeintacoma).  
For more information: [planning@cityoftacoma.org](mailto:planning@cityoftacoma.org), (253) 501-5030 (Option 4)

Requires internet access required  
English only  
Online only  
Have a computer and internet access  
Email: [planning@cityoftacoma.org](mailto:planning@cityoftacoma.org)  
Phone: (253) 501-5030

 CITY OF TACOMA  
PLANNING SERVICES  
747 MARKET STREET - ROOM 349  
TACOMA WA 98402

 **PREPARED  
RENDERING AND  
DEPENDENCE  
FOR  
TACOMA WA  
PERMIT 102**

ECRWSS  
Postal Customer



# Help shape the future of housing in Tacoma

To meet growing demands from the community for increased housing supply, affordability and choice, the City is considering the following proposed actions:

- Allow more housing types throughout Tacoma's neighborhoods
- Allow mid-scale multifamily housing in areas close to shopping and transit
- Update design standards so new housing complements the neighborhood
- Strengthen policies and programs to make housing more affordable
- Strengthen anti-racism and anti-displacement policies and programs

We are considering actions to adapt our rules and policies to support the development of more diverse and affordable housing options, along with steps to get neighborhood growth right.

To learn more about the proposed changes, visit [cityoftacoma.org/homeintacoma](http://cityoftacoma.org/homeintacoma) or join us for an

**INFORMATION MEETING:**

Thursday, March 18 at 5:30 p.m. on ZOOM  
(with Spanish live translation)

**PUBLIC HEARING:**

Wednesday, April 7 starting at 5:30 p.m.



## Tacoma's housing rules are changing

Living gives us a roof over our heads and connects us with community, jobs, schools and transportation—which matters to our health and wellbeing. Yet finding housing is hard, and many Tacoma residents pay more than they can afford.

Since the 1950s, Tacoma's residential zoning has set aside most of our neighborhoods for single-family houses—one of the least affordable and most prevalent housing types. This has limited housing choices and contributed to today's housing crisis.

In 2021 the City Council decided to make a change and started Tacoma on a path to allowing "middle" housing to be built citywide. The changes, when adopted, will allow more housing types in our neighborhoods—and more people to call Tacoma home.

---

### Home In Tacoma Phase 2 is underway

In 2023 Tacoma is seeking community input to create middle housing zoning and design standards, along with actions to ensure housing growth meets multiple goals. To learn about Tacoma's affordability strategy, visit [cityoftacoma.org/ahas](http://cityoftacoma.org/ahas).



#### Examples of middle housing supported by Tacoma's growth strategy

**Low-scale housing**



House & ADU



Duplex/triplex



Small lot house



Cottage housing

**Mid-scale housing**

(in some circumstances)



Fourplex



Small multifamily



Rowhouses



Medium multifamily

Tacoma's adopted housing growth strategy supports low-scale housing citywide and mid-scale housing in areas closest to shopping and transit.

## Join the discussion about how housing gets built in our neighborhoods



Everyone has a stake in housing and neighborhoods. Home In Tacoma – Phase 2 works on how to get housing growth right by focusing on middle housing design standards to promote neighborhood compatibility, infrastructure and amenities to support housing growth, and strategies to keep housing affordable and combat displacement.

This community conversation on housing will take place in 2023. Share your ideas and get involved by:

- Completing our Home In Tacoma survey
- Sharing your ideas on our online engagement platform
- Commenting on the scope of the City's Environmental Impact Statement
- Learning about upcoming engagement opportunities and in-person meetings

Visit [cityoftacoma.org/homeintacoma](http://cityoftacoma.org/homeintacoma) to get involved. Questions? Contact us at [homeintacoma@cityoftacoma.org](mailto:homeintacoma@cityoftacoma.org) or (253) 591-5030 (Option 6).

¿Necesitas información en español?  
 Si lo necesitas, llámanos al (253) 591-5030.  
 ¿Quieres participar en línea?  
 Visita [cityoftacoma.org/homeintacoma](http://cityoftacoma.org/homeintacoma) o  
 llámanos al (253) 591-5030.

Planning and Development Services  
 747 Market Street, Room 345  
 Tacoma, WA 98402

ECRWSS Postal Customer

# Ask MRSC • Transit

April 2022



## In This Issue

### Are face coverings still required on transit?

Is there an RCW or federal clause limiting the use of retainage bonds for a construction project when using Federal Funds?

How do I balance my role as a city council member or county commissioner/council member with my role as a transit authority board member? What if the best interests of one agency “conflict” with the best interests of the other? Must I seek guidance from my fellow council members before voting?

Did the Legislature amend the Open Public Meetings Act (OPMA) in the last session?

Some of our staff members are attending an industry conference. Can they accept a prize awarded by random drawing?

*Scroll down to read the answers*

### Have a question?

Officials and staff from eligible transit agencies can use our free one-on-one inquiry service, Ask MRSC.

Ask MRSC

### Are face coverings still required on transit?

The Federal Transit Administration had extended its requirement for face coverings on public transportation conveyances and hubs through May 3, 2022. However, a federal judge in Florida issued a nationwide order voiding the requirement on April 18, 2022. That order is being appealed. Local agencies still have the authority to require face coverings. Many regional transit agencies have publicly announced that they are no longer requiring masks. But, check with your agency counsel on the most current requirements.

### Is there an RCW or federal clause limiting the use of retainage bonds for a construction project when using Federal Funds?

The agency does not reserve retainage on public improvement contracts funded in whole or in part by federal transportation funds ([RCW 60.28.011\(1\)\(b\)](#)). Claims that would normally be paid for out of retainage under [RCW 39.08.010](#); or under [Titles 50, 51, and 82 RCW](#) are to be paid out of the contract's performance and payment bond. See [Federal Acquisition Regulation Section 28.102](#) for more details about the federal bond requirement and remember that the contract bond must stay in effect until all state requirements have been released.

**How do I balance my role as a city council member or county commissioner/council member with my role as a transit authority board member? What if the best interests of one agency “conflict” with the best interests of the other? Must I seek guidance from my fellow council members before voting?**

This question came to MRSC because the transit board was being asked to reduce its tax levy to make room for the use of those funds to build a much-needed mental health facility. This would have the immediate effect of reducing transit operations but would provide a benefit to the community at large.

There is no legally correct answer, but there are a few things to consider. Board members have those positions solely because of their respective city or county position. It is reasonable to assume that each board member will consider the effect of their board vote on their "home" jurisdiction. On the other hand, board members do have a fiduciary responsibility to act in the transit agency's best interests. As an elected official with responsibility for your "home" jurisdiction's budget you already balance competing interests, and this is just another place where you get to exercise your judgment.

As for seeking guidance from your colleagues, there is no statutory requirement that you do so. You were appointed to the transit board and with that appointment comes the authority to make decisions independently. Remember that the council or board can always take a formal position on the proposal regardless of how you vote on the transit board. But you may find it helpful to seek your colleagues' opinions and there is certainly no statute that prohibits you from doing so (of course, you'll remember to comply with the OPMA). As always, check with your agency attorney if you have questions about a specific action.

---

### Did the Legislature amend the Open Public Meetings Act (OPMA) in the last session?

Yes, it did. MRSC's Flannery Collins outlines the changes in a [recent blog post](#). As she writes "The most notable change (which is really more of a clarification) is that meetings subject to the OPMA must have a physical location (with a few allowed exceptions). Another significant change is the requirement for public comment at regular meetings where final action is taken." Meeting agendas for regular meetings must be posted online unless the agency:

- Has an aggregate valuation of the property subject to taxation by the district, city, or town of less than \$400,000,000;
- Has a population of under 3,000; and
- Provides confirmation to the state auditor that the cost of posting notices on its website or a shared website would exceed one-tenth of 1% of the local government's budget.

And if you go into executive session, you must include the purpose of the executive session in your meeting notes.

---

### Some of our staff members are attending an industry conference. Can they accept a prize awarded by random drawing?

Probably. [RCW 42.23.070\(2\)](#) prohibits accepting gifts "for a matter connected with or related to the officer's services." The purpose of [RCW 42.23.070\(2\)](#) is to prevent the purchase of influence or special treatment. In most circumstances, that concern likely has no relevance to a random drawing. Also, while state law does not provide an exception for gifts of little or no value, many agencies have adopted "*de minimis*" rules. The logic behind these rules is the assumption that something of low value is presumed to not influence the decision-maker. Also, if all attendees included in the random drawing are automatically entered then there's a good argument that it's not a "gift" because the right to participate is included in the registration cost for the conference. Check with your agency's attorney and review the agency's policies to see if this is addressed. If not, look at [MRSC's ethics page](#) for examples. You may want to allow staff to participate in a random drawing unless they are directly involved in a contract or other solicitation with the company providing the prize.

## Thank you to our generous sponsors



## Stay Informed

MRSC publishes a number of e-newsletters related to local government issues. You can also keep up with us on social media.

Manage your  
Subscription



If you have questions or comments for the newsletter editor, please contact [Steve Gross](#), Legal Consultant.

[MRSC.org](#)

Good evening, members of the council and Mayor Woodards,

I am here to protest Tacoma's rezoning of our properties and especially adding midscale along transit corridors that Transit has directed are to be built without parking so that folks use transit.

This is something that no one that I have spoken to agrees we should do. Also the properties you are adding more and more units and having them built on lot lines is dangerous and should not be allowed.

What is more disturbing is the fact that according to the Municipal Research Services Center – Transportation newsletter that I have kept since April 2022, says, and it reads :

How do I balance my role as a city councilmember, or county commissioner/council member with my role as a transit authority board member? What if the best interests of one agency "conflict" with the best interests of the other? Must I seek guidance from my fellow council members before voting?

The question came to MRSC because the transit board was being asked to reduce its tax levy to make room for the use of those funds to build a much-needed mental health facility. This would have the immediate effect of reducing transit operations but would provide a benefit to the community at large.

The response to that question:

**There is no legally correct answer, but there are a few things to consider. Board members have those positions solely because of their respective city or county position. It is reasonable to assume that each board member will consider the effect of their board vote on their "home" jurisdiction. On the other hand, board members do have a FIDUCIARY RESPONSIBILITY TO ACT IN THE TRANSIT AGENCY'S BEST INTERESTS. As an ELECTED OFFICIAL WITH RESPONSIBILITY FOR YOUR "HOME" jurisdiction's budget you already balance competing interests and this is just another place where you get to exercise your judgement.**



**What about the Transportation commissioners you appointed in August 2024 to the transportation commission? Are those the Commissioners mentioned? IF SO, THEY NEED TO BE GONE TOO.**

**DO NOT PASS THE HOME IN TACOMA ZONING CHANGES!!!**

Instead, manage the zoning changes already made by House Bill 1110, passed by the Washington Legislature in 2023

WE DO NOT NEED MIDSCALE. That is something that Transit wants so that they get more customers. Transit is just another company.

Victoria, Kristina, John, and whoever else is on that Transit Board need to resign from the City Council because YOU DO NOT REPRESENT TACOMA RESIDENTS BY ALLOWING THIS TO HAPPEN.

The Planning Dept must not have wanted to ensure that folks were made aware of rezoning. Especially since they kept sending Post Cards to POSTAL CUSTOMERS that never got delivered. We, the voters WANT YOU TO:

**DISCARD HIT AND WORK WITH HB110.** The City's own planning report states that Tacoma does not need these massive density increases in all our neighborhoods in order to meet 2050 housing targets. Instead, the City should emphasize developing multi-family complexes in downtown and in areas already zoned for large buildings. It should also focus on managing the development that will result from the zoning changes of HB 1110.

1. Hit does little to improve affordability.
2. Plans for infrastructure upgrades are inadequate.
3. Design standards are entirely inadequate to protect the character of existing streets.
4. HiT risks accelerating the displacement of current residents.
5. The Zoning Changes are inequitable.
6. We don't need HiT to reach our housing goals.

7. HiT provides inadequate protections for our Tree Canopy
8. HiT incentivizes the demolition and degradation of our historic buildings. It has no preservation requirements. And it only has weak incentives to preserve historic buildings.

I SAY AGAIN, You should resign from this Council if you cannot distinguish your responsibility to the People who elected you. We don't need councilmembers that don't stand up for our citizens and do what the citizens want – NOT WORK FOR SPECIAL INTERESTS!!!!.

**From:** Cathie Raine <cjrrd@hotmail.com>  
**Sent:** Monday, September 23, 2024 4:54 PM  
**To:** City Clerk's Office  
**Subject:** 'Home in Tacoma--Part 2' Comments for Public Hearing on 9/24/24.

ATTENTION..this e-mail contains the remainder of my 'comments' submitted earlier today..

Dear Mayor Woodards, Deputy Mayor Hines and Council Members,

Point #6: Pieces of critical information still not known or studied includes:

\*The City of Tacoma does not have a current/updated status report of a major aquifer (drinking water back up system)...yet is pushing for significant housing growth. If this new zoning plan is approved, what will the City of Tacoma do to obtain adequate water if the STGPD is unable to provide an adequate water supply in the future. The STGPD updates have been delayed until AFTER this new zoning change is anticipated to be approved. The 'Home in Tacoma'..or, any housing plan should not be approved until the aquifer studies are completed AND the 'South Tacoma Groundwater Protection District' code updates are completed and approved by the City Council.

\*NONE of the studies (and, recommendations) connected to this 'Home in Tacoma-Part 2' zoning plan change (Final EIS, HIA, 'Planning Commission Recommendations and Findings of Facts' report etc) have included ANY information on the potential/likely impacts of having a large fulfillment center/warehouse located within a (one) large neighborhood in Tacoma. Choosing to ignore the future impacts of a major development project...is very irresponsible!

As part of your review of all of the 'Home in Tacoma-Phase 2' information materials, please understand that review of the wording with the associated Tacoma Municipal Code changes is the most critical part of these zoning changes (these are THE legal aspects of this zoning change)

There is a push..by the Planning Commission and the 'Tacoma Permit Advisory Group' for the individual Planners to have the leeway/'carte blanche' to make exceptions and other variances with the approval of certain permit applications. This is NOT an appropriate plan!

Please consider a 'stall' with any approval of this 'Home in Tacoma-phase 2' zoning changes. These drastic, across the board/uniform zoning changes will not achieve a goal of significantly increasing affordable housing options. Instead, these zoning changes could result in irreversible harms for the Tacoma residents.

Thank you for your time and consideration.

Respectfully submitted,

Cathie (Raine) Urwin



**From:** Georgette Reuter <gee.reuter@gmail.com>  
**Sent:** Monday, September 23, 2024 4:55 PM  
**To:** City Clerk's Office  
**Subject:** In Support of the HiT landscaping Code

To Mayor Woodards and Tacoma City Council Members

One very important reason that I support the HiT Landscaping Code is that it provides necessary protections for our City's mature trees and requires that new trees be planted. And it is this important tree preservation and tree expansion in Tacoma that will provide **numerous ongoing financial benefits to our City**.

There is much research available that shows how our urban forests provide millions of dollars worth of financial benefits to our cities across our country.

Here is current research provided by the Arbor Day Foundation,  
"The Economic benefits of Urban Forestry in the United States".

**The United States Urban Forests create....**

\$5 Billion in Air Pollution Filtration

\$3 Billion in Stormwater Management

\$65 Billion in Carbon Storage (sequestration)

\$31.5 Billion Added Annually to Property Values Across the U.S

And the US Urban Forestry Sector directly contributes \$35 Billion Annually to the US economy

So, it's very clear that "**Money Really Does Grow on Trees!**"

**Please support our urban forest so that it may grow and thrive- then we'll not only will we have a healthy City in which to live, we'll receive huge financial benefits as well. It's a win-win!!**

Sincerely,  
Georgette Reuter  
2201 N. Union Avenue  
Tacoma

**From:** Rich Wood <mr.rgwood@gmail.com>  
**Sent:** Monday, September 23, 2024 4:56 PM  
**To:** City Clerk's Office  
**Subject:** Support for Home in Tacoma

I support Home in Tacoma. As a longtime homeowner in the North End, I am concerned about the lack of affordable housing options for younger people, families and folks with lower incomes.

We need more housing in Tacoma, and we need housing that is affordable. Current HIT plans appear to address concerns about improving our tree canopy and ensuring design compatibility with existing neighborhoods. We should prioritize development on existing vacant land before demolishing existing homes. Transit should be promoted as well.

Thank you,

Rich Wood  
1430 North Oakes Street  
Tacoma, WA 98406

**From:** Courtney Davis <c.davis622@gmail.com>  
**Sent:** Monday, September 23, 2024 4:39 PM  
**To:** Tom Giske  
**Cc:** City Clerk's Office  
**Subject:** Re: Comments Regarding Home in Tacoma Phase 2 Hearing

Niiice work, Tom!

On Mon, Sep 23, 2024 at 4:09 PM Tom Giske <[tgiske@gmail.com](mailto:tgiske@gmail.com)> wrote:

Please see attached Cover Letter and Attachment from Tacoma Urban Forest Friends as comments regarding Home in Tacoma Phase 2:

Tom Giske  
(425) 301-5925 (Voice or Text)

**From:** Torrez, Alyssa  
**Sent:** Monday, September 23, 2024 5:03 PM  
**To:** City Clerk's Office  
**Subject:** FW: Home in Tacoma Affordability

Please see comment for public hearing.

Best,  
Alyssa

-----Original Message-----

From: Adrienne Ione - Silver Linings Integrative Health <email@yes2aging.com>  
Sent: Monday, September 23, 2024 6:00 PM  
To: Home In Tacoma <HomeInTacoma@cityoftacoma.org>; Torrez, Alyssa <ATorrez@cityoftacoma.org>  
Subject: Home in Tacoma Affordability

Dear City Council Members

Thank you so much for your service to our beautiful community. As you know, Tacoma is absolutely strong, resilient and magnificent. Having lived in the area on and off since the 80s, I've seen changes ranging from remarkably inclusive to substantially damaging.

As you consider the next steps for Home in Tacoma, I strongly encourage you to keep in mind Section 2, of Resolution No. 40871 which states that the City of Tacoma strongly encourages the City's housing partners to use data-informed tools, such as community prioritization, to ensure more residents are able to stay in the City with a focus on households from "low" and "very low" opportunity areas of the City, as well as Black, Indigenous, and People of Color households.

As a City, we have a real opportunity to model unity, appreciation, and community while also meeting the needs of an increased population. Take for example the rezoning that take place at 1940 MLK Jr Way. Each unit is being sold at an asking price of \$565K. There are 8 units. The total assessed value of mprovements made is less than half of what is being requested for one. This is simple math where profit is greater than people.

I am confident you will do the right thing and emphasize the value of people.

With Respect,

Adrienne

...

Adrienne Ione, PsyD  
National Provider Identifier: 1063002921  
orcid.org/0000-0002-1077-1373  
Author: Dementia Grief Therapy

Silver Linings Integrative Health, LLC  
316 S. G Street / Tacoma, WA 98405  
Telephone: 253.988.6463  
youtube.com/@yoga... \*\*\* insighttimer/adrienneione



**From:** Peter Jung <peterj2@uw.edu>  
**Sent:** Monday, September 23, 2024 5:04 PM  
**To:** City Clerk's Office  
**Subject:** Home in Tacoma Phase 2 public comment

Hi,

My name is Peter Jung. I am a lifelong resident of Tacoma, and currently living in hilltop. I am a member of Tacoma's disability community, and a disability advocate. I am writing in support of Home in Tacoma, advocating that no further changes happen to water it down. A significant challenge many people with disabilities are facing is housing instability, and significant distance from medical and community resources in the areas that are affordable. By increasing housing density in Tacoma, especially along transit corridors, they have better access to essential services to both maintain their health and stay involved with their community. Please retain the reduced parking area, as central Tacoma needs it to add housing and tree canopy, while making enough space for transit accessible housing. Do not water down the proposal any further, as the housing and homelessness crisis is not going to get better without further housing being built.

Thank you,  
Peter Jung

--

Peter Jung M.Ed.  
(He/Him pronouns)

**From:** William Terrance <william.t.terrance@gmail.com>  
**Sent:** Monday, September 23, 2024 5:10 PM  
**To:** City Clerk's Office  
**Subject:** Comments on Home in Tacoma Zoning and Standards

Hello,

I was looking for the Zoom app for this meeting. I am only able to locate an app called "Zoon Workplace." Do you know if this is the correct app?

William Terrance

**From:** Jodi Cook <jodi.cook0983@gmail.com>  
**Sent:** Monday, September 23, 2024 4:59 PM  
**To:** City Clerk's Office; Hines, John; Rumbaugh, Sarah; Walker, Kristina; Diaz, Olgy; Scott, Jamika; Sadalge, Sandesh; Bushnell, Joe; Daniels, Kiara  
**Subject:** Save Our Tacoma Neighborhoods and Tree Canopy, petition -- Home in Tacoma Public Comment  
**Attachments:** Save Our Tacoma Neighborhoods and Tree Canopy Petition.pdf; Petition on Home in Tacoma September 24, 2024.docx

Public Opinion comments for City Council Meeting September 24, 2024 Home in Tacoma



[Don't Seattle My Tacoma](https://dontseattlemytacoma.com)  
[dontseattlemytacoma.com](https://dontseattlemytacoma.com)

## petition\_signatures\_jobs\_490171702\_20240923235115 (2)

<b>Name</b>	<b>City</b>	<b>State</b>	<b>Postal Code</b>	<b>Country</b>	<b>Signed On</b>
<b>Jodi Cook</b>	Tacoma	WA		US	2024-08-13
<b>Felicity Devlin</b>	Tacoma	WA	98406	US	2024-08-13
<b>Michael Foley</b>	Tacoma	WA	98406	US	2024-08-13
<b>Heidi White</b>	University Place	WA	98466	US	2024-08-14
<b>Cheri Carlson</b>	Browns Point	WA	98422	US	2024-08-14
<b>Tammy Bhang</b>	Tacoma	WA	98403	US	2024-08-15
<b>Tobi Bet</b>	Tacoma	WA	98405	US	2024-08-17
<b>Michael Malaier</b>	Tacoma	WA	98406	US	2024-08-17
<b>eugene mayer</b>	Tacoma	WA	98406	US	2024-08-17
<b>Sue Ryan</b>	Tacoma	WA	98406	US	2024-08-17
<b>Jeffrey Ryan</b>	Tacoma	WA	98407	US	2024-08-17
<b>Thomas Lowe</b>	Tacoma	WA	98406	US	2024-08-17
<b>Jane Ellis</b>	Tacoma	WA	98405	US	2024-08-17
<b>Jody Wright-Tenenberg</b>	Tacoma	WA	98406	US	2024-08-17
<b>Barbara Cordis-Lowe</b>	Seattle	WA	98118	US	2024-08-17
<b>Kyle Peppard</b>	Tacoma	WA	98406	US	2024-08-17
<b>James Strautman</b>	Tacoma	WA	98406	US	2024-08-17
<b>Lis Sanz</b>	Fullerton	CA	92831	US	2024-08-17
<b>Julia Martin</b>	Tacoma	WA	98405	US	2024-08-17
<b>Sean Drew</b>	Tacoma	WA	98406	US	2024-08-17
<b>Catherine Feeney</b>	Seattle	WA	98188	US	2024-08-18
<b>Diana Ely</b>	Tacoma	WA	98406	US	2024-08-18
<b>Brian Nation</b>	Seattle	WA	98122	US	2024-08-18
<b>Debbie Gaab</b>	St louis	MO	63126	US	2024-08-18
<b>Adam Kaluba</b>	Burleson	TX	76028	US	2024-08-18
<b>Jennifer McDonald</b>	Portland	OR	97202	US	2024-08-18
<b>Sheila Long</b>	Tacoma	WA	98406	US	2024-08-18
<b>Raney Ellis</b>	Tacoma	WA	98406	US	2024-08-18
<b>Hassan Paria</b>				US	2024-08-18

<b>Denise Kelly-Ballweber</b>	Tacoma	WA	98406	US	2024-08-18
<b>Patricia Lynn Lightwell</b>	Tacoma	WA	98407	US	2024-08-18
<b>Jean Webber</b>	Tacoma	WA	98407	US	2024-08-19
<b>James Reuter</b>	Tacoma	WA	98406	US	2024-08-19
<b>Erika Rikhiram</b>	Clermont	FL	34711	US	2024-08-19
<b>David Eichner</b>	Seattle	WA	98060	US	2024-08-19
<b>Cynthia Bertozzi Turco</b>	Portland	OR	97252	US	2024-08-19
<b>Carolyn Dimmer</b>	Tacoma	WA	98407	US	2024-08-19
<b>Lisa Palmer</b>				US	2024-08-19
<b>Angela Arms</b>	Tacoma	WA	98406	US	2024-08-19
<b>Alyssa Donohue</b>	Tacoma	WA	98407	US	2024-08-19
<b>Desiree Lewis</b>	Tacoma	WA	98407	US	2024-08-19
<b>Wendy Hickman</b>	Tacoma	WA	98406	US	2024-08-20
<b>Bess Poehlmann</b>	Tacoma	TX	98407	US	2024-08-20
<b>Robert Stephen</b>	Tacoma	WA	98406	US	2024-08-20
<b>Rod Cory</b>	Tacoma	WA	98406	US	2024-08-20
<b>Elizabeth Hetrick</b>	Tacoma	WA	98406	US	2024-08-20
<b>Thomas Riordan</b>	Tacoma	WA	98406	US	2024-08-20
<b>Mary Lyman</b>	Tacoma	WA	98405	US	2024-08-20
<b>Lauryn Bryant</b>	Tacoma	WA	98407	US	2024-08-20
<b>Tanya Headrick</b>	Puyallup	WA	98371	US	2024-08-20
<b>Nell Payne</b>	Tacoma	WA	98405	US	2024-08-20
<b>Jenn June</b>	Tacoma	WA	98406	US	2024-08-20
<b>Michael Lafreniere</b>	Tacoma	WA	98406	US	2024-08-21
<b>Megan Wright</b>	Seattle	WA	98101	US	2024-08-21
<b>Rick Donohue</b>	Tacoma	WA	98407	US	2024-08-21
<b>Kelly Yarkosky</b>	Tacoma	WA	98407	US	2024-08-21
<b>Christopher Vann</b>	Tacoma	WA	98406	US	2024-08-21
<b>Dena Alo-Colbeck</b>	Seattle	WA	98188	US	2024-08-21
<b>patricia fetterly</b>	Tacoma	WA	98405	US	2024-08-21
<b>Toni Murray</b>	Tacoma	WA	98407	US	2024-08-21
<b>Stacey Conley</b>	Tacoma	WA	98406	US	2024-08-21

<b>Rachel Nelson</b>	Tacoma	WA	98406	US	2024-08-21
<b>Deb Olsen</b>	Tacoma	WA	98408	US	2024-08-21
<b>Jonathan Pardo</b>	Tacoma	WA	98406	US	2024-08-21
<b>Brian Friske</b>	Tacoma	WA	98406	US	2024-08-22
<b>Mike Smith</b>	Tacoma	WA	98406	US	2024-08-22
<b>Kathleen Conn</b>	Tacoma	WA	98466	US	2024-08-22
<b>Nicola Tollefson</b>	Tacoma	WA	98402	US	2024-08-22
<b>Marse Lear</b>	Tacoma	WA	98405	US	2024-08-24
<b>joe Missel</b>	Tacoma	WA	98406	US	2024-08-25
<b>Julie and Jay Turner</b>	Tacoma	WA	98406	US	2024-08-25
<b>Esther Day</b>	Tacoma	WA	98408	US	2024-08-25
<b>Deanna Rickert</b>	Puyallup	WA	98374	US	2024-08-25
<b>Debbie Macdonald</b>	Tacoma	WA	98406	US	2024-08-25
<b>Rhonda Jones</b>	Bonney Lake	WA	98391	US	2024-08-25
<b>Robin Lubow</b>	Tacoma	WA	98409	US	2024-08-25
<b>Alice Skilton</b>	Tacoma	WA	98404	US	2024-08-25
<b>Christopher Skilton</b>	Tacoma	WA	98404	US	2024-08-25
<b>John Butler</b>	Portland	OR	97233	US	2024-08-25
<b>Karen Dinicola</b>	Tacoma	WA	98405	US	2024-08-26
<b>marvin vialle</b>	Tacoma	WA	98465	US	2024-08-26
<b>April Smith</b>	Tacoma	WA	98445	US	2024-08-26
<b>Anneliese Simons</b>	Tacoma	WA	98405	US	2024-08-26
<b>Judy Beylerian</b>	Tacoma	WA	98406	US	2024-08-26
<b>Joyce Brannon</b>	Tacoma	WA	98422	US	2024-08-26
<b>Kathleen Brooker</b>	Tacoma	WA	98403	US	2024-08-26
<b>Elisabeth Johnson</b>	Tacoma	WA	98403	US	2024-08-26
<b>Glenn Panameño</b>	Tacoma	WA	98408	US	2024-08-26
<b>Timothy McDonald</b>	Tacoma	WA	98406	US	2024-08-26
<b>Jon Inwood</b>	Brooklyn	NY	11226	US	2024-08-27
<b>Lisa Bitney</b>	Tacoma	WA	98406	US	2024-08-27
<b>Patrick McDermott</b>	Tacoma	WA	98406	US	2024-08-27
<b>Nancy McFarland</b>	Tacoma	WA	98466	US	2024-08-27

<b>Eva Anchondo</b>	Santa Fe	NM	87502	US	2024-08-27
<b>Rick Dinicola</b>	Tacoma	WA	98407	US	2024-08-27
<b>Jess Guatney</b>	Seattle	WA	98178	US	2024-08-27
<b>Edward Dugan</b>	Tacoma	WA	9805	US	2024-08-27
<b>Jill Keeton</b>	Tacoma	WA	98409	US	2024-08-27
<b>allie rucker</b>	Olympia	WA	98516	US	2024-08-27
<b>Ryan Rittenhouse</b>	Tacoma	WA	98402	US	2024-08-27
<b>Susan Hayami</b>	Tacoma	WA	98405	US	2024-08-27
<b>Kristine Countryman</b>	Tacoma	WA	98407	US	2024-08-27
<b>REBECCA SPLINTER</b>	Tacoma	WA	98403	US	2024-08-27
<b>Ember Divers</b>	tacoma	WA	98407	US	2024-08-27
<b>Cathleen countryman</b>	Tacoma	WA	98407	US	2024-08-27
<b>Jonathan Palinkas</b>	Tacoma	WA	98406	US	2024-08-27
<b>Kerry Taylor</b>	Seattle	WA	98118	US	2024-08-27
<b>P M</b>	Tacoma	WA	98406	US	2024-08-27
<b>Linda Perkins</b>	Tacoma	WA	98407	US	2024-08-27
<b>Vernadette Thie</b>	Seattle	WA	98118	US	2024-08-28
<b>KELLY THOMAS</b>	Tacoma	WA	98406	US	2024-08-28
<b>Louise Dreyer</b>	Tacoma	WA	98408	US	2024-08-28
<b>Jackie Burk</b>	Tacoma	WA	98403	US	2024-08-28
<b>Loraine Post</b>	Tacoma	WA	98406	US	2024-08-28
<b>Kenneth Ross</b>	Tampa	FL	33634	US	2024-08-28
<b>Corrina Markley</b>	Tacoma	WA	98406	US	2024-08-28
<b>Patricia Shannon</b>	Seattle	WA	98198	US	2024-08-28
<b>Jennifer Fields</b>	Bluffton	SC	29910	US	2024-08-29
<b>Suzette Rangel</b>	Tacoma	WA	98405	US	2024-08-29
<b>Scott Nelson</b>	Tacoma	WA	98406	US	2024-08-29
<b>Mullan Scott</b>	Tacoma	WA	98405	US	2024-08-29
<b>P Fawver</b>	Tacoma	WA	98466	US	2024-08-30
<b>Sobia Nasir</b>	Hollywood	FL	33023	US	2024-08-30
<b>Orva M Gullett</b>	Marion	OH	43302-8435	US	2024-08-30
<b>Kurt Graupensperger</b>	Tacoma	WA	98406	US	2024-08-30

<b>Jackeline Diaz</b>	Memphis	TN	38111	US	2024-08-31
<b>Anaiyah Billups</b>	Peoria	IL	61604	US	2024-08-31
<b>Nathan Rucker</b>	Seattle	WA	98160	US	2024-08-31
<b>Heather Warren</b>	Tacoma	WA	98403	US	2024-08-31
<b>Delbert Boyer</b>	Tacoma	WA	98408	US	2024-08-31
<b>Kaylee Revell</b>				US	2024-09-01
<b>CJ Elsen</b>	Aberdeen	SD	57401	US	2024-09-01
<b>Lisa Pedersen</b>	Tacoma	WA	98409	US	2024-09-01
<b>Alexandria Gallagher</b>	Seattle	WA	98118	US	2024-09-01
<b>Becky Steffan</b>	Tacoma	WA	98406	US	2024-09-01
<b>Tony Stefanko</b>	Tacoma	WA	98465	US	2024-09-01
<b>Brittany Fritts</b>	Gig Harbor	WA	98332	US	2024-09-01
<b>Dathany Y</b>	Seattle	WA	98103	US	2024-09-01
<b>Suzanne Dye</b>	Tacoma	WA	98408	US	2024-09-01
<b>Margaret Sinding</b>	Tacoma	WA	98422	US	2024-09-01
<b>Jana Lovely</b>	Tacoma	WA	98466	US	2024-09-01
<b>Rhonda Sample</b>	Tacoma	WA	98418	US	2024-09-01
<b>James Stevens</b>	Seattle	WA	98118	US	2024-09-01
<b>Martin Bennett</b>	Tacoma	WA	98418	US	2024-09-01
<b>Stacy Goss</b>	Tacoma	WA	98407	US	2024-09-01
<b>Steve Diamanti</b>	Tacoma	WA	98406	US	2024-09-01
<b>Wendy Batman</b>	Tacoma	WA	98406	US	2024-09-01
<b>Cindy Scerri</b>	Puyallup	WA	98373	US	2024-09-01
<b>Rayna Dye</b>	Tacoma	WA	98408	US	2024-09-01
<b>Roxann Hackler</b>	Spanaway	WA	98387	US	2024-09-01
<b>Jane VerValin</b>	Tacoma	WA	98407	US	2024-09-01
<b>David Phill</b>	University Place	WA	98467	US	2024-09-01
<b>William Peterson</b>	Ankeny	IA	50021	US	2024-09-01
<b>Deborah Barnett</b>	Tacoma	WA	98403	US	2024-09-01
<b>Dana Missel</b>	Seattle	WA	98144	US	2024-09-01
<b>James Milam</b>	Tacoma	WA	98403	US	2024-09-01
<b>Nicole Forsythe</b>	Tacoma	WA	98405	US	2024-09-01



<b>Brandon Vollmer</b>	Tacoma	WA	98444	US	2024-09-01
<b>Josh Standiford</b>	Lake Zurich	IL	60047	US	2024-09-01
<b>Stephanie Santoni</b>	Tacoma	WA	98444	US	2024-09-01
<b>Christy Scerra</b>	Tacoma	WA	98407	US	2024-09-01
<b>Kenneth Iverson</b>	Tacoma	WA	98407	US	2024-09-01
<b>Linda Sliva</b>	Tacoma	WA	98404	US	2024-09-01
<b>Daphney Tennard</b>	Houston	TX	77037	US	2024-09-01
<b>Steven Dartt</b>	Tacoma	WA	98404	US	2024-09-01
<b>Michael Davis</b>	Tacoma	WA	98405	US	2024-09-01
<b>Mayra Quezada</b>	Tacoma	WA	98408	US	2024-09-01
<b>Megan Boly</b>	Tacoma	WA	98406-5324	US	2024-09-01
<b>Bonnie Browning</b>	GRAHAM	WA	98338	US	2024-09-02
<b>Beth Frick</b>	Seattle		98166	US	2024-09-02
<b>Brittnee Brundage</b>	Tacoma	WA	98409	US	2024-09-02
<b>Young-Mi Rudolph</b>	Tacoma	WA	98404	US	2024-09-02
<b>Randolph Clark</b>	Seattle	WA	98103	US	2024-09-02
<b>Debra Anderson</b>	Tacoma	WA	98404	US	2024-09-02
<b>Angelica Harvey</b>	Seattle	WA	98408	US	2024-09-02
<b>Alana Preziosi</b>	Swedesboro	NJ	8085	US	2024-09-02
<b>LaVonna Houston</b>	Tacoma	WA	98409	US	2024-09-02
<b>Teresa Byerley</b>	Tacoma	WA	98406	US	2024-09-02
<b>Ryan Bailey</b>	Seattle	WA	98122	US	2024-09-02
<b>Scott Meyers</b>	Seattle	WA	98198	US	2024-09-02
<b>Shamela Sullivan</b>	Tacoma	WA	98404	US	2024-09-02
<b>Judy Hazelton</b>	Tacoma	WA	98407	US	2024-09-02
<b>Kirsten Carlson</b>	Tacoma	WA	98406	US	2024-09-02
<b>Timothy Ausink</b>	Tacoma	WA	98406	US	2024-09-02
<b>Jessica Malaier</b>	Tacoma	WA	98406	US	2024-09-02
<b>Linda Titus</b>	Tacoma	WA	98403	US	2024-09-02
<b>Christie Woolard</b>	Tacoma	WA	984455	US	2024-09-02
<b>Charles Carlson</b>	Seattle	WA	98178	US	2024-09-02
<b>Brady Fukuhara</b>	Tacoma	WA	98404	US	2024-09-02

<b>Kathleen Brisbois</b>	Tacoma	WA	98406	US	2024-09-02
<b>Dawn Seaholm</b>	Tacoma	WA	98422	US	2024-09-02
<b>Wallace Miller</b>	Tacoma	WA	98406	US	2024-09-02
<b>Elizabeth Swain</b>	Tacoma	WA	98407	US	2024-09-02
<b>Bryan Obi</b>	Carrollton	TX	75007	US	2024-09-02
<b>Kris Zachary</b>	Tacoma	WA	98405	US	2024-09-02
<b>Lynn Cox-Hakanson</b>	Tacoma	WA	98466	US	2024-09-02
<b>Heidi Shilley-Towne</b>	Tacoma	WA	98408	US	2024-09-02
<b>J DAY</b>	Federal Way	WA	98003	US	2024-09-02
<b>KRISTEN ALLOTT</b>	Tacoma	WA	98405	US	2024-09-02
<b>Paula Demmer</b>	Tacoma	WA	98407	US	2024-09-02
<b>Doris Kitchen</b>	Hendersonville	NC	28739	US	2024-09-02
<b>Kathryn Lickteig</b>	Tacoma	WA	98407	US	2024-09-02
<b>Emilie Silva</b>	Tacoma	WA	98407	US	2024-09-02
<b>Linda Lauritzen</b>	Tacoma	WA	98405	US	2024-09-03
<b>kimberly buchanan</b>	Tacoma	WA	98404	US	2024-09-03
<b>Kelly Lucas</b>	Tacoma	WA	98406	US	2024-09-03
<b>john urbonas</b>	Plainfield	IL	60586	US	2024-09-03
<b>Pamela Strickland</b>	Tacoma	WA	98424	US	2024-09-03
<b>Kimberly Poland</b>	Tacoma	WA	98405	US	2024-09-03
<b>Kelly Hartman</b>	Yelm	WA	98597	US	2024-09-03
<b>Luke Williams</b>	Bonney Lake	WA	98391	US	2024-09-03
<b>Ellen Kohjima</b>	Tacoma	WA	98418	US	2024-09-03
<b>Linda diane Worthy</b>	Gig Harbor	WA	98332	US	2024-09-03
<b>shyenne rogers</b>	Tacoma	WA	98422	US	2024-09-03
<b>Barbara DuBois</b>	Tacoma	WA	98406	US	2024-09-03
<b>Kenn Prosser</b>	Tacoma	WA	98466	US	2024-09-03
<b>Robert Black</b>	Seattle	WA	98178	US	2024-09-03
<b>Tyler Kolbo</b>	Tacoma	WA	98424	US	2024-09-03
<b>Dan Joslin</b>	Tacoma	WA	98406	US	2024-09-03
<b>Shelley McDaniel</b>	Tacoma	WA	98405	US	2024-09-03
<b>Gail Caldwell</b>	Seattle	WA	98118	US	2024-09-03

<b>Ronald Bone</b>	Tacoma	WA	98406	US	2024-09-03
<b>Geoffrey Block</b>	Tacoma	WA	98406	US	2024-09-03
<b>Susan Phan</b>	Tacoma	WA	98406	US	2024-09-03
<b>Annette Perry</b>	Federal Way	WA	98003	US	2024-09-03
<b>Khanh Phan</b>	Renton	WA	98057	US	2024-09-03
<b>Marlene warfield</b>	Tacoma	WA	98406	US	2024-09-03
<b>Catherine Nicholas-Whit</b>	Seattle	WA	98160	US	2024-09-03
<b>Emily Woodward</b>	Tacoma	WA	98406	US	2024-09-03
<b>Melissa Bland</b>	Tacoma	WA	98406	US	2024-09-03
<b>Marilyn Henderson</b>	Tacoma	WA	98404	US	2024-09-03
<b>Jamie Hammontree</b>	Seattle	WA	98160	US	2024-09-03
<b>Stephanie Lansdale-Trox</b>	university place	WA	98466	US	2024-09-03
<b>Laurena Manke</b>	Tacoma	WA	98406	US	2024-09-03
<b>Amanda Fern</b>	Tacoma	WA	98493	US	2024-09-03
<b>Sarah Bliesath</b>	Tacoma	WA	98422	US	2024-09-03
<b>Michael Johnson</b>	Tacoma	WA	98406	US	2024-09-03
<b>David Olson</b>	Tacoma	WA	98406	US	2024-09-03
<b>Ashley Hendrickson</b>	Seattle	WA	98406	US	2024-09-03
<b>JULIE CARLSEN</b>	Tacoma	WA	98403	US	2024-09-03
<b>Juliane Burbach</b>	Tacoma	WA	98408	US	2024-09-03
<b>Katheryn Ridgley</b>	University Place	WA	98466	US	2024-09-03
<b>Carole Sladek</b>	Tacoma	WA	98406	US	2024-09-03
<b>Debora Brese</b>	Tacoma	WA	98409	US	2024-09-03
<b>Sally Radford</b>	Tacoma	WA	98409	US	2024-09-03
<b>Michelle Ledbetter</b>	Tacoma	WA	98406	US	2024-09-03
<b>John Strobel</b>	Seattle	WA	98144	US	2024-09-03
<b>Joyce Schuetz</b>	Ocean Shores	WA	98569	US	2024-09-03
<b>Patricia Hodges</b>	Tacoma	WA	98406	US	2024-09-03
<b>Richard Aspuria</b>	Renton	WA	98055	US	2024-09-03
<b>Cynthia Schaapveld</b>	Tacoma	WA	98445	US	2024-09-04
<b>Verda Washington</b>	Tacoma	WA	98405	US	2024-09-04
<b>Kristie Nolta</b>	Tacoma	WA	98409	US	2024-09-04

<b>Jennifer Kolbo</b>	Tacoma	WA	98406	US	2024-09-04
<b>Mary Ann Clabaugh</b>	Tacoma	WA	98406	US	2024-09-04
<b>Colette Candy</b>	Tacoma	WA	98406	US	2024-09-04
<b>Sharon Glassy</b>	Tacoma	WA	98408	US	2024-09-04
<b>Cindy Arnold</b>	Seattle	WA	98118	US	2024-09-04
<b>MariLlyn Fellows</b>	Tacoma	WA	98406	US	2024-09-04
<b>Aife Pasquale</b>	Tacoma	WA	98408	US	2024-09-05
<b>Friday Sutherland</b>	Tacoma	WA	98418	US	2024-09-05
<b>Cathie Urwin</b>	Seattle	WA	98198	US	2024-09-05
<b>Steven Watts</b>	Seattle	WA	98108	US	2024-09-05
<b>Sally Burke</b>	Tacoma	WA	98404	US	2024-09-05
<b>Evelyn Hale</b>	Seattle	WA	98198	US	2024-09-05
<b>Jenny Allen-Holland</b>	Tacoma	WA	98404	US	2024-09-05
<b>Jill Jensen</b>	Tacoma	WA	984606	US	2024-09-05
<b>Patricia Pavolka</b>	Tacoma	WA	98407	US	2024-09-05
<b>Timothy Pavolka</b>	Tacoma	WA	98406	US	2024-09-05
<b>Anna Christensen</b>	Tacoma	WA	98405	US	2024-09-05
<b>darlene Conley</b>	Tacoma	WA	98466	US	2024-09-05
<b>Karlene Frazier</b>	Tacoma	WA	98424	US	2024-09-05
<b>Ryan Massey</b>	Tacoma	WA	98405	US	2024-09-05
<b>Steve Jones</b>	Tacoma	WA	98404	US	2024-09-05
<b>Karen Hume</b>	Tacoma	WA	98466	US	2024-09-05
<b>Ashley walls</b>	Seattle	WA	98198	US	2024-09-05
<b>Susan Monin</b>	Tacoma	WA	98407	US	2024-09-05
<b>Betty Lindgren</b>	Tacoma	WA	98408	US	2024-09-05
<b>Chenda Ouch</b>	Tacoma	WA	98418	US	2024-09-05
<b>Monica Miklova</b>	Seattle	WA	98107	US	2024-09-05
<b>Tylee Tuch</b>	Portland	OR	97212	US	2024-09-05
<b>katherine finnigan</b>	Tacoma	WA	98404	US	2024-09-05
<b>Henry Thompson</b>	Allyn	WA	98524	US	2024-09-06
<b>Kriszta Kotsis</b>	Tacoma	WA	98406	US	2024-09-06
<b>Jeff McCormick</b>	Tacoma	WA	98407	US	2024-09-06

<b>Janelle McCormick</b>	Tacoma	WA	98407	US	2024-09-06
<b>Elliot Jackson</b>	Tacoma	WA	98405	US	2024-09-06
<b>Chris Quivers</b>	Richmond	VA	23225	US	2024-09-06
<b>Erika Ergen</b>	Inverness	FL	34450	US	2024-09-06
<b>Erin Ellis</b>	Tacoma	WA	98406	US	2024-09-06
<b>Kandie Kizzez</b>	Pittsburg	CA	94565	US	2024-09-06
<b>Michael Muller</b>	Tacoma	WA	98406	US	2024-09-06
<b>Monika Reynolds</b>	Tacoma	WA	98402	US	2024-09-06
<b>Clara Fink</b>	Tacoma	WA	98407	US	2024-09-06
<b>Kelly Seivert</b>	Tacoma	WA	98406	US	2024-09-06
<b>Wendy Van Vechten</b>	Gig Harbor	WA	98335	US	2024-09-06
<b>Heidi Hayes</b>	Tacoma	WA	98406	US	2024-09-06
<b>Tami Wilson</b>	Steilacoom	WA	98388	US	2024-09-06
<b>Francisco Lares Benitez</b>	Puyallup	WA	98374	US	2024-09-06
<b>Burroughs Anderson</b>	Tacoma	WA	98406	US	2024-09-06
<b>Casey McClinton</b>	Tacoma	WA	98405	US	2024-09-06
<b>Pierre Greene</b>	Tacoma	WA	98402	US	2024-09-06
<b>Jan Masenga</b>	Tacoma	WA	98403	US	2024-09-06
<b>Douglas Budzynski</b>	Tacoma	WA	98406	US	2024-09-06
<b>Christian Corridon</b>	Tacoma	WA	98445	US	2024-09-06
<b>Joe Carbajal</b>	Tacoma	WA	98405	US	2024-09-06
<b>Claudia Dickinson</b>	Bonney Lake	WA	98391	US	2024-09-06
<b>Anthony Sturdivant</b>	Grand Haven	MI	49417	US	2024-09-06
<b>Lea Rash</b>	Auburn	WA	98092	US	2024-09-06
<b>Maggie Hess</b>	Seattle	WA	98023	US	2024-09-07
<b>Alicia McCormick</b>	Renton	WA	98057	US	2024-09-07
<b>Michael Solberg</b>	Tacoma	WA	98406	US	2024-09-07
<b>Kat Dollarhide</b>	Puyallup	WA	98371	US	2024-09-07
<b>Christine Neitzke</b>	Tacoma	WA	98445	US	2024-09-07
<b>Ally Orosco</b>	Valladolid	WA	97780	Mexico	2024-09-07
<b>Tyana Simsich</b>	Tacoma	WA	98406	US	2024-09-07
<b>Phillip Fetzer</b>	Tacoma	WA	98402	US	2024-09-07

<b>Angela Wolle</b>	Tacoma	WA	98409	US	2024-09-07
<b>Benjamin Snow</b>	Tacoma	WA	98404	US	2024-09-07
<b>Leza Leddingham Leddi</b>	Hilliard	OH	43026	US	2024-09-07
<b>Christine Rothschiller</b>	Lakewood		98499	US	2024-09-07
<b>Tracy Hahn</b>	Seattle	WA	98136	US	2024-09-07
<b>Alley Perry</b>	Tacoma	WA	98421	US	2024-09-07
<b>Marlena Anspach</b>	Tacoma	WA	98408	US	2024-09-07
<b>Mary Ann Harshman</b>	Tacoma	WA	98422	US	2024-09-08
<b>Michelle Campos</b>	Tacoma	WA	98406	US	2024-09-08
<b>Chris Ellis</b>	TACOMA	WA	98406	US	2024-09-08
<b>Nelson Rascon</b>	Tacoma	WA	98405	US	2024-09-08
<b>Gary Droeger</b>	Huntington Beach	CA	92648	US	2024-09-08
<b>Andrea Plotkin</b>	Tacoma	WA	98401	US	2024-09-08
<b>Troy Cheslik</b>	Tacoma	WA	98406	US	2024-09-08
<b>Aiyana Stringer</b>	Tacoma	WA	98402	US	2024-09-08
<b>Malachi Tracy</b>	Seattle	WA	98406	US	2024-09-08
<b>Deborah Brookshier</b>	Tacoma	WA	98408	US	2024-09-08
<b>Heather Dartt</b>	Tacoma	WA	98407	US	2024-09-09
<b>Bruce LeBkanc</b>	Kent	WA	98032	US	2024-09-09
<b>Margaret Guertin</b>	Tacoma	WA	98404	US	2024-09-09
<b>Stephanie breedlove</b>	Tacoma	WA	98403	US	2024-09-09
<b>max bridges</b>	Tacoma	WA	98466	US	2024-09-09
<b>Bobbie Flowers</b>	Port Jefferson Sta	NY	11776	US	2024-09-09
<b>Cynthia Droeger</b>	Huntington Beach	CA	92648	US	2024-09-09
<b>Tomoko Okada</b>	Tacoma	WA	98465	US	2024-09-09
<b>KEVIN BUSELMEIER</b>	Tacoma		98466	US	2024-09-09
<b>Christine Arend</b>	Tacoma		98443	US	2024-09-09
<b>Chantelle Weaver</b>	Tacoma	WA	98409	US	2024-09-09
<b>Kristin Mildner</b>	Tacoma	WA	98445	US	2024-09-09
<b>Erik Olson</b>	Tacoma	WA	98406	US	2024-09-10
<b>Lori Goodrich</b>	University Place	WA	98466	US	2024-09-10
<b>Meredith Kaupp</b>	Tacoma	WA	98408	US	2024-09-10

<b>Candace Yarbrough</b>	Tacoma	WA	98466	US	2024-09-10
<b>Kathleen McCarthy</b>	Tacoma	WA	98465	US	2024-09-10
<b>Susan Rucker</b>	Tacoma	WA	98493	US	2024-09-10
<b>Dianne Stefanko</b>	Tacoma	WA	98406	US	2024-09-10
<b>Kathleen Ellingson</b>	Tacoma	WA	98406	US	2024-09-10
<b>Sylvia Boskovich</b>	Tacoma	WA	98406	US	2024-09-10
<b>Carol Kovanda</b>	Tacoma	WA	98465	US	2024-09-10
<b>Myrteese Mata</b>	Los Angeles	CA	90063	US	2024-09-10
<b>Michele Caple</b>	Tacoma	WA	98406	US	2024-09-10
<b>Eda Roosna</b>	Tacoma	WA	98465	US	2024-09-10
<b>Jeanene Pedee</b>	Tacoma	WA	98404	US	2024-09-10
<b>Allison Cutrona</b>	Buffalo	NY	14224	US	2024-09-10
<b>Susan Ellsworth</b>	Tacoma	WA	98408	US	2024-09-11
<b>Kristin Downing</b>	Tacoma	WA	98406	US	2024-09-11
<b>Nancy Zemek</b>	Tacoma	WA	98465	US	2024-09-11
<b>Mark A Ludvigson</b>	Tacoma	WA	98465-1302	US	2024-09-11
<b>f h</b>	Gig Harbor	WA	98335	US	2024-09-11
<b>Robert Hess</b>	Tacoma	WA	98422	US	2024-09-11
<b>Melanie Freshwaters</b>	Tacoma	WA	98407	US	2024-09-11
<b>Timothy McKamey</b>	Puyallup	WA	98374	US	2024-09-11
<b>Diana stephens</b>	TACOMA	WA	98465	US	2024-09-12
<b>ROBIN &amp; Sandra PETER</b>	Tacoma	WA	98465	US	2024-09-12
<b>Margaret Anderson</b>	Tacoma	WA	98405	US	2024-09-12
<b>R Blackwood</b>	Tacoma	WA	98409	US	2024-09-12
<b>James Schock</b>	Seattle	WA	98178	US	2024-09-12
<b>Madilyn Head</b>	Lakewood	WA	98498	US	2024-09-12
<b>Angelea Tobacco</b>	Tacoma	WA	98405	US	2024-09-12
<b>Terry Tobacco</b>	Tacoma	WA	98466	US	2024-09-12
<b>Kathleen Voie</b>	Tacoma	WA	98406	US	2024-09-12
<b>Christopher Stubel</b>	Tacoma	WA	98403	US	2024-09-13
<b>Janie Swiney</b>	Gig Harbor	WA	98335	US	2024-09-13
<b>Wolfgang Wagner</b>	Tacoma	WA	98465	US	2024-09-13

<b>Jane OUYANG</b>	Tacoma	WA	98465	US	2024-09-13
<b>Audrey Shilander</b>	Tacoma	WA	98422	US	2024-09-13
<b>Liselotte Barrows</b>	Tacoma	WA	98407	US	2024-09-13
<b>Jennifer Mannix</b>	Tacoma	WA	98405	US	2024-09-13
<b>Heather Black</b>	Tacoma	WA	98406	US	2024-09-13
<b>Jacqueline Summer Mur</b>	Tacoma	WA	98406	US	2024-09-13
<b>Ranell Nystrom</b>	Tacoma	WA	98405	US	2024-09-13
<b>Christina Manetti</b>	Lakewood	WA	98499	US	2024-09-13
<b>Bernadette kjellesvik</b>	Tacoma	WA	98465	US	2024-09-13
<b>Jane Eichner</b>	Tacoma	WA	98406	US	2024-09-13
<b>Melissa Cason</b>	Tacoma	WA	98407	US	2024-09-13
<b>Rich Langsford</b>	Tacoma	WA	98406	US	2024-09-13
<b>Amanda Foltz</b>	Tacoma	WA	98407	US	2024-09-13
<b>Krischel Sollars</b>	Tacoma	WA	98407	US	2024-09-13
<b>Joni Firth</b>	Wenatchee	WA	98801	US	2024-09-13
<b>Melissa Siedlicki</b>	Tacoma	WA	98407	US	2024-09-13
<b>Lisa Markwart</b>	Cicero	IL	60804	US	2024-09-13
<b>John Lane</b>	Lakewood	WA	98498	US	2024-09-13
<b>Rachelle Martz</b>	University Ol	WA	98466	US	2024-09-13
<b>alyssa Elliott</b>	Seattle	WA	98178	US	2024-09-13
<b>Jane Frazer</b>	Tacoma	WA	98404	US	2024-09-13
<b>Scott gray</b>	Tacoma	WA	98407	US	2024-09-13
<b>Al Attebery</b>	Tacoma	WA	98406	US	2024-09-13
<b>Patrick Morse</b>	Tacoma		98408	US	2024-09-13
<b>Debra Larsen</b>	Tacoma	WA	98406	US	2024-09-13
<b>Erika Bergman</b>	Tacoma	WA	98407	US	2024-09-13
<b>Maryanne Kraeger</b>	Tacoma	WA	98406	US	2024-09-13
<b>Elizabeth Wight</b>	Tacoma	WA	98407	US	2024-09-13
<b>Jim Cornelius</b>	Tacoma	WA	98422	US	2024-09-13
<b>Danny Ing</b>	Tacoma	WA	98404	US	2024-09-13
<b>Tiana Gondek</b>	Tacoma	WA	98407	US	2024-09-13
<b>Paula Aplin</b>	Tacoma	WA	98407	US	2024-09-13



<b>Chad Gorbatkin</b>	Tacoma	WA	98406	US	2024-09-13
<b>Midori Dunbar</b>	Tacoma	WA	98408	US	2024-09-13
<b>Marcia Garrett</b>	Tacoma	WA	98407	US	2024-09-13
<b>Sharon Barber</b>	Tacoma	WA	98466	US	2024-09-14
<b>Elizabeth Rosenblatt</b>	Federal Way	WA	98003	US	2024-09-14
<b>Roberta R Czarnecki</b>	Everett	WA	98204	US	2024-09-14
<b>Kara Jensen</b>	Tacoma	WA	98406	US	2024-09-14
<b>Jolene Agostini</b>	Tacoma	WA	98407	US	2024-09-14
<b>Cynthia Crose</b>	Tacoma	WA	98406	US	2024-09-14
<b>Stan Hearn</b>	Tacoma	WA	98406	US	2024-09-14
<b>K C</b>	Seattle	WA	98178	US	2024-09-14
<b>Kip Clinton</b>	Lakebay	WA	98349	US	2024-09-14
<b>Michelle Nichols</b>	Seattle	WA	98121	US	2024-09-14
<b>Michelle Gray</b>	Tacoma	WA	98407	US	2024-09-14
<b>Allison Witt</b>	Tacoma	WA	98424	US	2024-09-14
<b>Teresa Bierbaum</b>	UNIVERSITY PLA	WA	98466	US	2024-09-14
<b>Clarity Dickinson</b>	Tacoma	WA	98405	US	2024-09-14
<b>Brianne Pederson</b>	Seattle	WA	98115	US	2024-09-14
<b>Greta Nuse</b>	Tacoma	WA	98406	US	2024-09-14
<b>O Fayth</b>	Tacoma	WA	98406	US	2024-09-14
<b>Kathryn McAuley</b>	Tacoma	WA	98407	US	2024-09-14
<b>Amanda Springer</b>	Tacoma	WA	98406	US	2024-09-14
<b>Robbin Wall</b>	Tacoma	WA	98406	US	2024-09-14
<b>Cynthia Hammer</b>	Tacoma	WA	98402	US	2024-09-14
<b>Dan Besett</b>	Redmond	OR	97756	US	2024-09-14
<b>Carol Hearn</b>	Tacoma	WA	98407	US	2024-09-14
<b>Gisela Taranovski</b>	Tacoma	WA	98406	US	2024-09-14
<b>Earl Perdue</b>	Tacoma	WA	98407	US	2024-09-14
<b>Jean Jones</b>	Federal Way	WA	98003	US	2024-09-15
<b>Madison Hastings</b>	Ocala	FL	34470	US	2024-09-15
<b>Diane Mason</b>	Seattle	WA	98122	US	2024-09-15
<b>Janet Lind</b>	Tacoma	WA	98407	US	2024-09-15

<b>Diana Stephens</b>	Lakewood	WA	98498	US	2024-09-15
<b>Kimberly Gratzner</b>	Puyallup	WA	98375	US	2024-09-15
<b>Xiomara Juarez</b>	Tacoma	WA	98406	US	2024-09-15
<b>Brian Bumpers</b>	Seattle	WA	98168	US	2024-09-15
<b>John Rieber</b>	Tacoma	WA	98445	US	2024-09-15
<b>Will Nuse</b>	Tacoma	WA	98406	US	2024-09-15
<b>Courtney Boitano</b>	Tacoma	WA	98406	US	2024-09-15
<b>Gayle Rieber</b>	Seahurst	WA	98062	US	2024-09-15
<b>Dave Loe</b>	Lakewood	WA	98498	US	2024-09-15
<b>Nancy Shulenberger</b>	Tacoma	WA	98422	US	2024-09-15
<b>Susan Heywood</b>	Tacoma	WA	98408	US	2024-09-15
<b>Kelly Sapstead</b>	Tacoma	WA	98406	US	2024-09-16
<b>Bruce Hadaway</b>	Tacoma	WA	98406	US	2024-09-16
<b>Christine Becker</b>	Tacoma	WA	98406	US	2024-09-16
<b>Mayra Brito</b>	Federal Way	WA	98023	US	2024-09-16
<b>Erin Pedersen</b>	Tacoma	WA	98407	US	2024-09-16
<b>Nancy Westcott</b>	Portland	OR	97251	US	2024-09-16
<b>Karlisha Price</b>	Kansas City	MO	64130	US	2024-09-16
<b>Linda Price</b>	Bothell	WA	98041	US	2024-09-16
<b>James Lineweaver</b>	Tacoma	WA	98407	US	2024-09-16
<b>Ryan Starceвич</b>	Tacoma	WA	98406	US	2024-09-16
<b>Christopher Rosati</b>	Dallas	TX	75270	US	2024-09-16
<b>Justine Russo</b>	Tacoma	WA	98406	US	2024-09-16
<b>Monika May</b>	Tacoma	WA	98409	US	2024-09-16
<b>Jill Rohrbaugh</b>	Tacoma	WA	98404	US	2024-09-16
<b>Joan Parks</b>	Tacoma	WA	98405	US	2024-09-16
<b>Justin Webber</b>	Tacoma	WA	98405	US	2024-09-16
<b>bruce titus</b>	Tacoma	WA	98409	US	2024-09-16
<b>Katelynn Kindall</b>	Tacoma	WA	98409	US	2024-09-16
<b>vince tovar</b>	Lakewood	WA	98498	US	2024-09-16
<b>Lisa Gran</b>	Tacoma	WA	98404	US	2024-09-16
<b>victoria heinz</b>	Tacoma	WA	98406	US	2024-09-16

<b>Mary Jo Strom Copland</b>	Tacoma	WA	98407	US	2024-09-16
<b>Jeff Lucas</b>	Tacoma	WA	98406	US	2024-09-16
<b>Cynthia Price</b>	Tacoma	WA	98405	US	2024-09-17
<b>Samuel Adams</b>	Tacoma	WA	98406	US	2024-09-17
<b>Cathy Elford</b>	Tacoma	WA	98493	US	2024-09-17
<b>Sapna S</b>	Seattle	WA	98168	US	2024-09-17
<b>Patrick Gele</b>	Tacoma	WA	98406	US	2024-09-17
<b>Frank Spence</b>	Seattle	WA	98118	US	2024-09-17
<b>Barbara Cain</b>	Tacoma	WA	98465	US	2024-09-17
<b>Bernadine Moody</b>	Tacoma	WA	98404	US	2024-09-17
<b>Brigid Olson</b>	Tacoma	WA	98404	US	2024-09-17
<b>Sean Moody</b>	Tacoma	WA	98404	US	2024-09-17
<b>Richard Ranch</b>	Tacoma	WA	98407	US	2024-09-17
<b>Bebe Smith</b>	Tacoma	WA	98418	US	2024-09-17
<b>Farhana Zabidi</b>	Tacoma	WA	98465	US	2024-09-17
<b>Sharon Nugent</b>	Bonney Lake	WA	98391	US	2024-09-17
<b>Nanny Coogan</b>	Tacoma	WA	98406	US	2024-09-17
<b>Susan Woolery</b>	Seattle	WA	98108	US	2024-09-17
<b>Holly Blue</b>	Seattle	WA	98108	US	2024-09-17
<b>Scott Wagner</b>	Tacoma	WA	98465	US	2024-09-17
<b>Janice Bishop</b>	Lakewood	WA	98498	US	2024-09-17
<b>Marylon Simpson</b>	Federal Way	WA	98003	US	2024-09-17
<b>BRANDON WILLIAMS</b>	Tacoma	WA	98403	US	2024-09-17
<b>Timmie Parrish</b>	Tacoma	WA	98409	US	2024-09-17
<b>Theodore Willke</b>	Tacoma	WA	98465	US	2024-09-18
<b>Suzanne Wagner</b>	Tacoma	WA	98465	US	2024-09-18
<b>Darryl Heine</b>	Barrington	IL	60010	US	2024-09-18
<b>Aron Prenovost</b>	Seattle	WA	98108	US	2024-09-18
<b>Deborah Bailey</b>	Tacoma	WA	98404	US	2024-09-18
<b>Dave Boitano</b>	Seattle	WA	98101	US	2024-09-18
<b>Minh Luu</b>	Tacoma	WA	98465	US	2024-09-18
<b>Adam Cooper</b>	Tacoma	WA	98405	US	2024-09-18

<b>Marylou Layton-Eccles</b>	Raleigh	NC	27603	US	2024-09-18
<b>Lori Smith</b>	Tacoma	WA	98404	US	2024-09-19
<b>Jeff Smith</b>	Tacoma	WA	98404	US	2024-09-19
<b>Delcenia Slade</b>	Tacoma	WA	98404	US	2024-09-19
<b>Sheri Liguori</b>	Tacoma	WA	98405	US	2024-09-19
<b>Jeanne Adams</b>	Tacoma	NY	98406	US	2024-09-19
<b>Cheri Prichard</b>	Tacoma	WA	98407	US	2024-09-19
<b>Water Me Loan 64</b>	Wheeling	IL	60004	US	2024-09-19
<b>Robert Foote</b>	Tacoma	WA	98407	US	2024-09-19
<b>Joelene Moore</b>	North Richland H	TX	76180	US	2024-09-19
<b>Gregory Rudebaugh</b>	Tacoma	WA	98404	US	2024-09-19
<b>Bonnie O'Leary</b>	Tacoma	WA	98406	US	2024-09-19
<b>Julie Kangas</b>	Tacoma	WA	98422	US	2024-09-19
<b>Ryan Gowin</b>	Tacoma	WA	98406	US	2024-09-19
<b>Merrill Kelley</b>	Seattle	WA	98160	US	2024-09-19
<b>Charmel Sessions</b>	Seattle	WA	98160	US	2024-09-19
<b>Candace Sessions</b>	Tacoma	WA	98406	US	2024-09-19
<b>Kimberly Peters</b>	Tacoma	WA	98444	US	2024-09-19
<b>Siri Anna Everett</b>	Colorado Springs	CO	80909	US	2024-09-19
<b>Aaliyah Bey</b>	Toledo	OH	43612	US	2024-09-19
<b>Patti White</b>	Seattle	WA	98160	US	2024-09-19
<b>Richard Mahaffey</b>	Tacoma	WA	98406	US	2024-09-19
<b>Carl Bouffiou</b>	Tacoma	WA	98407	US	2024-09-19
<b>Jody Hart</b>	Seattle	WA	98118	US	2024-09-19
<b>Ellen Cohen</b>	Tacoma	WA	98406	US	2024-09-19
<b>Lisa Villegas</b>	Tacoma	WA	98403	US	2024-09-19
<b>thomas moore</b>	Houston	TX	77084	US	2024-09-19
<b>Brook Carrion</b>	Tacoma	WA	98407	US	2024-09-19
<b>Rene Ramos-Orozco</b>	Seattle	WA	98178	US	2024-09-19
<b>Stephanie Roof</b>	Tacoma	WA	98424	US	2024-09-20
<b>Seri Strong</b>	Seattle	WA	98104	US	2024-09-20
<b>Steve Williams</b>	Tacoma	WA	98406	US	2024-09-20

<b>Jaime Dait</b>	Tacoma	WA	98403	US	2024-09-20
<b>Midge Daniels</b>	TSeattle	WA	98118	US	2024-09-20
<b>Azaria Azene</b>	Tacoma	WA	98465	US	2024-09-20
<b>Madison Daugherty</b>	Tacoma	WA	98422	US	2024-09-20
<b>Ari Efaw</b>	Tacoma	WA	98444	US	2024-09-20
<b>Shoaib Bajwa</b>	CHENAB NAGAF	PA	97124	US	2024-09-20
<b>Omar Camareno</b>	Tacoma	WA	98403	US	2024-09-20
<b>Maricela Valdez Berumen</b>				US	2024-09-20
<b>Susan Hett</b>	Dublin	GA	31021	US	2024-09-20
<b>Blue Sandrock</b>	Seattle	WA	98118	US	2024-09-20
<b>Adam Torkar</b>	Seattle	WA	98122	US	2024-09-20
<b>Michael Holloway</b>	Tacoma	WA	98406-6906	US	2024-09-20
<b>John B</b>	Seattle	WA	98133	US	2024-09-20
<b>Diane Palmquist</b>	Tacoma	WA	98406	US	2024-09-20
<b>Dawn Nanfito</b>	Tacoma	WA	98407	US	2024-09-20
<b>Fiona Grant</b>	Puyallup	WA	98374	US	2024-09-20
<b>Lydia Korolak</b>	Kent	WA	98030	US	2024-09-20
<b>Robert Jordan</b>	Tacoma	WA	98407	US	2024-09-20
<b>Carmen Beaudry</b>	TACOMA	WA	98406	US	2024-09-20
<b>Cole Brame</b>	Tacoma	WA	98406	US	2024-09-20
<b>Robert Thoms</b>	Tacoma	WA	98403	US	2024-09-20
<b>Tanya Hodel</b>	Tacoma	WA	98424	US	2024-09-20
<b>Janice Brame</b>	Tacoma	WA	98406	US	2024-09-20
<b>Paula Bond</b>	Gig Harbor	WA	98335	US	2024-09-20
<b>Brian Greenhalgh</b>	Tacoma	WA	98422	US	2024-09-20
<b>Mary Hause</b>	Renton	WA	98058	US	2024-09-20
<b>Blake Koehn</b>	Tacoma	WA	98407	US	2024-09-20
<b>Sharon Styer</b>	Tacoma	WA	98406	US	2024-09-20
<b>Christie Schultz</b>	Tacoma	WA	98407	US	2024-09-20
<b>Steve Schultz</b>	Tacoma	CA	98407	US	2024-09-20
<b>Laurel Madson Lawson</b>	Tacoma	WA	98445	US	2024-09-20
<b>Brett Johnson</b>	Tacoma	WA	98406	US	2024-09-20

<b>Paula Varner</b>	Tacoma	WA	98405	US	2024-09-20
<b>thomas moore</b>	Tacoma	WA	98407	US	2024-09-20
<b>Amanda Skrivanich</b>	Tacoma	WA	98406	US	2024-09-20
<b>Steve Wescott</b>	Tacoma	WA	98424	US	2024-09-20
<b>Mary Kay Taylor</b>	Tacoma	WA	98422	US	2024-09-20
<b>Richard Garrett</b>	Tacoma	WA	98406	US	2024-09-20
<b>Melinda Gordon</b>	Tacoma	WA	98403	US	2024-09-20
<b>Kristi Gray</b>	Tacoma	WA	98374	US	2024-09-20
<b>Christopher Horan</b>	Seattle	WA	98101	US	2024-09-20
<b>Mark Larsen</b>	Tacoma	WA	98407	US	2024-09-20
<b>Jill Nunez</b>	Buckley	WA	98321	US	2024-09-20
<b>Robert Stebanski</b>	Tacoma	WA	98406	US	2024-09-20
<b>Mollie Heilesen</b>	Tacoma	WA	98407	US	2024-09-20
<b>Peter Gulsrud</b>	Tacoma	WA	98406	US	2024-09-20
<b>David Rodenbach</b>	Tacoma	WA	98493	US	2024-09-20
<b>ALICE BRUNS</b>	Tacoma	WA	98422	US	2024-09-20
<b>Renee Paine</b>	Tacoma	WA	98406	US	2024-09-20
<b>Elizabeth Salvo</b>	Tacoma	WA	98465	US	2024-09-20
<b>Greg Mowat</b>	Tacoma	WA	98407	US	2024-09-20
<b>Tom Baier</b>	Tacoma	WA	98403	US	2024-09-20
<b>Paul Keller</b>	Tacoma	WA	98406	US	2024-09-20
<b>George Heusel</b>	Tacoma	WA	98465	US	2024-09-20
<b>Amanda Brown</b>	Tacoma	WA	98406	US	2024-09-21
<b>Kathleen Forte</b>	Seattle	WA	98118	US	2024-09-21
<b>melanie moor</b>	TACOMA	WA	98403	US	2024-09-21
<b>Carla Moschetti</b>	Tacoma	WA	98407	US	2024-09-21
<b>Wanda West</b>	Tacoma	WA	98405	US	2024-09-21
<b>Judith Halstead</b>	Tacoma	WA	98406	US	2024-09-21
<b>Colleen Olin</b>	Seattle	WA	98118	US	2024-09-21
<b>Marsha Cunningham</b>	Tacoma	WA	98407	US	2024-09-21
<b>John Clemens</b>	Tacoma	WA	98407	US	2024-09-21
<b>Joan Joachims</b>	Tacoma	WA	98406	US	2024-09-21

<b>Lori Fleck</b>	Bonney Lake	WA	98391	US	2024-09-21
<b>Robert Kelly</b>	Tacoma	WA	98406	US	2024-09-21
<b>Susan Mattern</b>	Tacoma	WA	98407	US	2024-09-21
<b>Maria REMICK</b>	Tacoma	WA	98407	US	2024-09-21
<b>Cheryl Hansen</b>	Tacoma	WA	98404	US	2024-09-21
<b>Leonard Long</b>	Portland	OR	97251	US	2024-09-21
<b>David Lee</b>	Seattle	WA	98106	US	2024-09-21
<b>Niki Kelly</b>	Seattle	WA	98118	US	2024-09-21
<b>Ashlie Solomon</b>	Tacoma	WA	98424	US	2024-09-21
<b>Jean Elliott</b>	Tacoma	WA	98422	US	2024-09-21
<b>April Smith</b>	Tacoma	WA	98445	US	2024-09-21
<b>Jackson Donley</b>	Walbridge	OH	43465	US	2024-09-21
<b>Scott Wright</b>	Federal Way	WA	98003	US	2024-09-21
<b>Judy Knold</b>	Tacoma	WA	98407	US	2024-09-21
<b>Kathryn Seley</b>	Tacoma	WA	98422	US	2024-09-21
<b>Jon Day</b>	Tacoma	WA	98406	US	2024-09-21
<b>Aaron Chavez</b>	Seattle	WA	98103	US	2024-09-21
<b>Janna Davies</b>	Seattle	WA	98108	US	2024-09-21
<b>William F. Johnston Krist</b>	Tacoma	WA	98406	US	2024-09-21
<b>Mary Eri-Carlson</b>	Tacoma	WA	98407	US	2024-09-21
<b>Jennie Haws Sebree</b>	Seattle	WA	98117	US	2024-09-21
<b>Donna Calvert</b>	Tacoma	WA	98404	US	2024-09-21
<b>Jenny Davidson</b>	Tacoma	WA	98422	US	2024-09-21
<b>Bryanna Fulghum</b>	Tacoma	WA	98422	US	2024-09-21
<b>Amy Lundquist</b>	Tacoma	WA	98407	US	2024-09-21
<b>Michael Nanfito</b>	Seattle	WA	98118	US	2024-09-21
<b>Lisa Dyer</b>	Tacoma	WA	98409	US	2024-09-21
<b>Meagan Green</b>	Seattle	WA	98109	US	2024-09-21
<b>Gregory Stroud</b>	Tacoma	WA	98466	US	2024-09-22
<b>Connie Hardy</b>	Seattle	WA	98105	US	2024-09-22
<b>Karen Kaeo</b>	Seattle	WA	98108	US	2024-09-22
<b>Kelly Sarver-Lenderink</b>	Tacoma	WA	98403	US	2024-09-22

<b>Elizabeth McAmis</b>	Tacoma	WA	98407	US	2024-09-22
<b>Cynthia Grassest</b>	Tacoma	WA	98403	US	2024-09-22
<b>JUSTIN STEYER</b>	Tacoma	WA	98407	US	2024-09-22
<b>gina mears</b>	Tacoma	WA	98405	US	2024-09-22
<b>Melanie Kelly</b>	Tacoma	WA	98404	US	2024-09-22
<b>Lori Rundle</b>	Tacoma	WA	98404	US	2024-09-22
<b>Gregory Bettridge</b>	Des Moines	WA	98198	US	2024-09-22
<b>Robert Johnson</b>	Tacoma	WA	98418	US	2024-09-22
<b>Jessica VanCleaf</b>	Tacoma	WA	98406	US	2024-09-22
<b>LOREY DONALDSON</b>	Tacoma	WA	98405	US	2024-09-22
<b>Corinne Ells</b>	Seattle	WA	98122	US	2024-09-22
<b>Josh Percival</b>	Seattle	WA	98117	US	2024-09-22
<b>Jeffrey Olson</b>	Tacoma	WA	98406	US	2024-09-22
<b>Eric Moore</b>	Tacoma	WA	98407	US	2024-09-22
<b>linda waiss</b>	Federal Way	WA	98023	US	2024-09-22
<b>Phil Marr</b>	Tacoma	WA	98422	US	2024-09-22
<b>Kimberley Hitchcock</b>	Tacoma	WA	98404	US	2024-09-22
<b>Julie Veeck</b>	Tacoma	WA	98407	US	2024-09-22
<b>Jessica Corddry</b>	Tacoma	WA	98116	US	2024-09-22
<b>Lisa Mulhall</b>	Wenatchee	WA	98801	US	2024-09-22
<b>doug walker</b>	Tacoma	WA	98408	US	2024-09-22
<b>Deborah Raney</b>	Tacoma	WA	98107	US	2024-09-22
<b>James Kuhlman</b>	Tacoma	WA	98403	US	2024-09-22
<b>Sherry Fobes</b>	Tacoma	WA	98406	US	2024-09-22
<b>Michael Turco</b>	Washington	WA	98406	US	2024-09-23
<b>Simon Evancho</b>	Tacoma	WA	98407	US	2024-09-23
<b>Paula Demmer</b>	Tacoma	WA	98407	US	2024-09-23
<b>Donna Tims</b>	Gig Harbor	WA	98335	US	2024-09-23
<b>Maureen Shuler</b>	Seattle	WA	98108	US	2024-09-23
<b>Riot Green</b>	Pencil Bluff	AR	71965	US	2024-09-23
<b>Tim Fikse</b>	Tacoma	WA	98465	US	2024-09-23
<b>April Azzarello</b>	Tacoma	WA	98407	US	2024-09-23



<b>Scott Carnahan</b>	Tacoma	WA	98407	US	2024-09-23
<b>Timothy Beecher</b>	Seattle	WA	98148	US	2024-09-23
<b>Keisha Wilson</b>	Tacoma	WA	98407	US	2024-09-23
<b>Aubree Huckelbery</b>	Jamestown	NY	14701	US	2024-09-23
<b>Yasmine Horton</b>	Bessemer	AL	35020	US	2024-09-23
<b>Mary Pipes</b>	Tacoma	WA	98406	US	2024-09-23
<b>Karen Kelly</b>	Tacoma	WA	98465	US	2024-09-23
<b>Nina Rook</b>	Tacoma	WA	98407	US	2024-09-23
<b>Greg Duras</b>	Tacoma	WA	98406	US	2024-09-23
<b>Ingelaurie Lisher</b>	Tacoma	WA	98406	US	2024-09-23
<b>Adam Palomba</b>	Rockaway	NJ	7866	US	2024-09-23
<b>Jennifer Rollins</b>	Wichita	KS	67206	US	2024-09-23
<b>Alyssa Matthews</b>	Tacoma	WA	98407	US	2024-09-23
<b>Michael kinnear</b>	Tacoma	WA	98422	US	2024-09-23

September 23, 2024

Respectfully Mayor Woodward, Deputy Mayor Hines and esteemed City Council Members

–

Planning and Development Services leadership in January of this year, made a radical change to increase Tacoma's unit density targets to twice what the State House Bill 1110 requires in formerly single-family neighborhoods.

We hoped the Planning Commission's public input process in March this year, would count the written and oral comments made, and provide a percentage who supported these new measures in Home in Tacoma Phase II, and those who did not. Pretty standard data analysis. Didn't happen, hard data of residents living in our beautiful neighborhoods was ignored. By one person's count of all written letters, 77% did not favor these new bonus targets. Where is the public input data from various public outreach workshops, e.g. Mason Middle School. None.

Thus our November 2021 campaign "Save Our Tacoma Neighborhoods and Tree Canopy" which accumulated in less than a month over 2,300 signatures, along with many other voices, opposed Planning Commission's recommendations during Phase I. Fortunately, that City Council and Mayor Woodward listened to residents and substantially reduced the residential neighborhoods targeted for "Mid-scale".

After the July 30<sup>th</sup> presentation to the City Council Study Session, on the updated HIT Phase II, Save Our Tacoma Neighborhoods and Tree Canopy campaign has relaunched. By accessing the "Don't Seattle My Tacoma" website, viewers will more clearly understand the dramatic changes just this year and what residents stand to lose. Judge for themselves if PDS and Planning Commission have made good on promises made via Phase I.

Our campaign in the last 10+ days has over 675 signatures and we continue to build. We support the Planning Commission's work to finally integrate within the Tacoma Municipal Code tree protection, that should be a part of the walk back to updating just to HB1110 density levels. But Master Builders, the Permit Advisory Commission are a one-sided issue group, who don't even support trees as our Climate Crisis continues to unfold.

We ask you now to listen to residents who love this city, financially support this City and should have a have a stronger right to say how they want their city to move forward to responsibly integrate density. We are your voters and constituents. Treat us responsibly. Or if in a quandary, wait for elections that put Home in Tacoma 2 on a ballot.

Sincerely,  
Jodi Cook, resident

**From:** Anique Zimmer <aniquezimmer@gmail.com>  
**Sent:** Monday, September 23, 2024 4:52 PM  
**To:** City Clerk's Office  
**Subject:** Home in Tacoma public comment

Hello,

As a resident of Hilltop I want to write in my support for the current stage of this project.

Our need for denser housing (including mixed-use buildings) is desperately needed, and this plan has the potential to bring not just affordable housing but also a place for community vibrance, culture and more opportunities for small businesses. I hope to attend the meeting tomorrow, but if not I wanted to express how excited I am to see how it will change our city for the better!

Thank you,

~ Anique Zimmer

**From:** Matt Wakefield <matthew.w.wakefield@gmail.com>  
**Sent:** Monday, September 23, 2024 4:58 PM  
**To:** City Clerk's Office  
**Subject:** Public Comment: Support for Home in Tacoma Zoning and Standards

Hello,

I would like to voice my support for the planning commission's recommendation for the Home in Tacoma Zoning and Standards package.

Thank you,

Matt Wakefield

**From:** kristen@historic1625.com  
**Sent:** Monday, September 23, 2024 5:27 PM  
**To:** City Clerk's Office  
**Cc:** kristen@historic1625.com  
**Subject:** No on HIT 2

Dear Councilmembers,

Home in Tacoma 2 simply goes too far. Without question, Tacoma must ensure that it's code aligns with State law and make any needed changes to come into comfort with new state law on zoning. But, make no mistake, that new state law and the changes it will bring to Tacoma are already significant. It would be reckless to ram through HIT 2 which goes well beyond what is required by State law. We can take it more slowly. Saying NO to the radical changes that would be allowed by HIT 2 is the right thing to do from a public policy perspective, and it would show that you are listening to and value the perspective of your constituents.

The Council should vote no on HIT 2 and direct the planning department to scale back their proposal to what is required by State law. While I recognize that great effort has gone into this proposal, that effort sadly has ignored too many in the community who repeatedly have sent the message to you our elected council that this is too radical for Tacoma. Be aware, voters will not forget. When it comes to something as cherished as Tacoma's uniquely special neighborhoods and to people's investments in their homes, their memory will be long.

Vote No on HIT 2.

With Respect,  
Kristen Wynne  
206-972-5299

**From:** Gwenda Felizardo <felizardo2@comcast.net>  
**Sent:** Monday, September 23, 2024 6:02 PM  
**To:** City Clerk's Office  
**Subject:** Comments Regarding Home in Tacoma to Council

Owners of homes should be able to build on at least 80% of their lot size. Currently new builds occupy practically the full lot especially on 25 and 50 foot parcels.

Owners of older homes should be able to build various configurations in order to meet their personal needs which include ADU's and garages that are bigger than 1000 sq ft if the lot size is 6000 sq ft or larger.

Thank you,  
Gwen Felizardo

**From:** Mary Ann Leberg <lebergm83@gmail.com>  
**Sent:** Monday, September 23, 2024 5:33 PM  
**To:** City Clerk's Office  
**Subject:** Rezoning for greater density of housing

Greetings!

I can't come to the meeting tomorrow night because I'm working. So here are my written comments on the proposed rezoning of residential neighborhoods.

This Must Not Happen! Period!

In Seattle, houses were bulldozed to make way for apartments in what had been single-family neighborhoods. There was no eminent domain! This happened to a friend of mine. His family home was bulldozed. It was structurally sound, and there was no reason to tear it down. The house was bulldozed to make way for these ghastly, ugly-looking apartments. He was never compensated for the loss. Not one penny! And, uglier than that, if you think you are going to bulldoze people's homes in order to make way for apartments, and put people out of their homes, and out of their inheritances, you will have an ugly fight on your hands, make no mistake about it!

The apartments in Seattle did nothing to provide affordable housing. The rents in Seattle have risen to astronomical levels, where a one-bedroom apartment rents for \$2500 per month! It's this kind of greed that's causing the homeless problem, and now you are proposing to turn more people out of their homes, and force them to become renters, or to become homeless! Horrors!!

This ghastly piece of legislation must simply not be passed. It is based upon the misconception that this area will grow exponentially in the next 10, 20, or 30 years, and the statistics show that because of Covid, life expectancy has dropped, and is now at 77.5 years. Also, statistically, people are leaving Washington State now, and not coming here in droves as in the past. The gentrification has caused them to pack up and look elsewhere for a better cost of living, and for a much better tax base.

So, the premises upon which this legislation is founded are false. And, for these misbegotten reasons, you would destroy people's homes? This morally bankrupt piece of legislation simply must not be passed at all! If you want to build anything, then situate it upon the vacant lots that I keep seeing in downtown Tacoma. Just appropriate them, and you can put up any size apartments you want! Destroying people's homes will make the developers rich and will be a big pork barrel for the politicians, and that is all. In previous hearings, when I've been there in person, I've brought up the question of eminent domain, and have found that there are absolutely no plans for paying anyone anything to take their homes. You would deprive people of their homes and would deprive them and their heirs any chance at an inheritance! This is so outrageously morally bankrupt. It simply must not happen!

Mary Ann Leberg  
[lebergm83@gmail.com](mailto:lebergm83@gmail.com)

**From:** Brendan Haigh <brendan.haigh@outlook.com>  
**Sent:** Monday, September 23, 2024 7:13 PM  
**To:** Hines, John; Diaz, Olgy; Walker, Kristina; City Clerk's Office  
**Subject:** I Support Home in Tacoma!

Dear Mayor and City Council Members,

I just want to say that I fully support building more homes in the City of Tacoma, and I encourage the City Council to adopt policies in line with the "Higher Zoning Alternative" laid out by staff. The City of Tacoma should legalize building more homes, and different kinds of homes, throughout the city. I live in District One, and work downtown. Let's take advantage of this opportunity to increase housing options and decrease rents throughout the city. I look forward to having more neighbors, and to the vibrant and growing community that we'll create together!

Sincerely,

Brendan Haigh  
2719 N Cheyenne  
Tacoma, WA



**From:** Greg Hyde <ghyde34@gmail.com>  
**Sent:** Monday, September 23, 2024 7:37 PM  
**To:** City Clerk's Office  
**Subject:** Comments on Amended Ordinance No. 28793

Hi,

I am a homeowner and resident of Tacoma (since 2020) and I'm writing to express my strong support for the city wide rezoning. Over the past several years, rent and house prices have increased dramatically because housing supply has not kept up with the number of people who want to live in our great city. As these prices have gone up, people get priced out of neighborhoods they grew up in, and others end up never moving to Tacoma and we miss out on the vibrancy they can bring to our community.

In my own neighborhood there is a duplex in poor repair that has been sitting empty for a year, and the more that we can streamline the building process, whether for a single family home, a duplex, or an 8 unit apartment building, the better it is for our neighborhood and our city.

Thank you,  
Greg Hyde

**From:** Nancy Campbell <nancy@nmcampbell.com>  
**Sent:** Tuesday, September 24, 2024 8:23 AM  
**To:** City Clerk's Office  
**Subject:** Home in Tacoma Zoning Changes

City Council Members,

We wonder why citizens lose faith in government. What you have done with your proposed zoning changes is an example of why faith is lost.

We the people, fought hard to support ways to increase density in city neighborhoods that did not result in having high story buildings mixed in with one story houses. You complied with this request but now you have changed the zoning to allow for eight unit apartment buildings in single family neighborhoods. These neighborhoods support smaller apartment uses, duplexes, ADUs and the like but not big apartment buildings.

This is a clear example of "bait and switch" and is why we have lost faith in the Council. At a time when we need confidence in our democracy, you have eroded that with this change. I am saddened and disappointed in your willingness to not listen to the very community members who elected you.

Nancy Campbell

Nancy M. Campbell  
56 East Road, Tacoma WA 98406  
[nancy@nmcampbell.com](mailto:nancy@nmcampbell.com)  
206 718 6843

Confidentiality Notice: This e-mail message, including any attachments, is for the sole use of the intended recipient(s) and may contain confidential and privileged information. Any unauthorized review, use, disclosure, or distribution is prohibited. If you are not the intended recipient, please contact the sender by reply e-mail and destroy all copies of the original message. Thank you.

**From:** Steve Allsop <s.allsop.37@gmail.com>  
**Sent:** Tuesday, September 24, 2024 8:43 AM  
**To:** City Clerk's Office  
**Subject:** Fwd: Following up

Hello. I am forwarding previous correspondence with DM Hines regarding HIT2, which I would like included in the official record of today's public hearing.

I now see that, though the public hearing has been widely advertised as being today, that written comments were due yesterday. That doesn't make sense to me. Today is the public hearing and I am submitting comments, just as if I attended on-line or in person (which I cannot do today). I request that these comments be included.

Thank you.  
Steve Allsop  
2201 N Lawrence St

----- Forwarded message -----

From: **Steve Allsop** <[s.allsop.37@gmail.com](mailto:s.allsop.37@gmail.com)>  
Date: Thu, May 9, 2024 at 11:10 AM  
Subject: Following up  
To: Hines, John <[john.hines@cityoftacoma.org](mailto:john.hines@cityoftacoma.org)>

Hi, John. Thanks for the time yesterday. I hope things went well out on the slope.

As we discussed, the section of N 21st from Alder to Union has no bus service and no objective means of being deemed a "corridor". Now it has become the catalyst for the new UR2 designation that has painted our neighborhood yellow. That designation does not meet any objective criteria in our neighborhood.

That being said, perhaps UR2 can be eliminated in that area. That, and a "mid-scale light" designation for the corridor itself (perhaps the corridor reverts to UR2?) would go a long way to providing relief for a neighborhood where the midscale designation is not a fit, nor justified by the objective criteria mandated by the state or suggested by the Planning Commission.

If the map were revised to change the "mid-scale" on the corridor to UR2 ("mid-scale light"), and the UR2 intrusion into the neighborhood were eliminated, the above goals would be met without a wholesale elimination of the corridor, which you have stated is a non-starter.

This seems to me to be a reasonable, defensible position and I appreciate your consideration.

Also, I haven't bugged you about the Amici House project since I know the decision does not involve the Council. However, Director Huffman has twice now been quoted as follows: " Although Huffman said the zoning capacity is likely to increase in the coming year as part of the city's affordable housing action and growth strategy plan, Home in Tacoma, the proposal is being reviewed under the policies and codes in place at the time the application was completed." This implies that Home In Tacoma's provisions would allow the Amici project which is far far outside the "advertised" density contemplated by HIT. This "loophole" should be plugged as Council considers HIT2.

Best regards,  
-- Steve

**From:** Stew Messman <stewmessman@aol.com>  
**Sent:** Tuesday, September 24, 2024 9:04 AM  
**To:** City Clerk's Office  
**Subject:** Home in Tacoma Public Comment

Tacoma City Council:

House Bill 1110 will provide needed housing and allow low-scale buildings.

We wish to preserve the livability of our neighborhoods.

Home In Tacoma goes too far and should be abandoned.

Thank you.

Carla & Stewart Messman  
1536 S Fernside Dr  
Tacoma, WA 98465

**From:** Bry Osmonson <bosmonson@gmail.com>  
**Sent:** Tuesday, September 24, 2024 10:32 AM  
**To:** City Clerk's Office  
**Subject:** In support of HIT

Hello,  
I'm writing in support of Home in Tacoma phase 2. We need dramatically more housing in the city and the region. Tacoma would be a better place to live with more neighbors!  
More density everywhere, especially near high capacity transit!

Bry Osmonson, AICP

**From:** Torrez, Alyssa  
**Sent:** Tuesday, September 24, 2024 3:21 PM  
**To:** City Clerk's Office  
**Subject:** FW: Comment on Home in Tacoma FEIS  
**Attachments:** ST\_Comment\_HomeInTacoma\_FEIS\_092424\_FINAL.pdf

---

**From:** Wiatr, Diane <[diane.wiatr@soundtransit.org](mailto:diane.wiatr@soundtransit.org)>  
**Sent:** Tuesday, September 24, 2024 1:49 PM  
**To:** Torrez, Alyssa <[ATorrez@cityoftacoma.org](mailto:ATorrez@cityoftacoma.org)>  
**Cc:** Hawkins, Curvie <[Curvie.Hawkins@soundtransit.org](mailto:Curvie.Hawkins@soundtransit.org)>; Green, Erin <[erin.green@soundtransit.org](mailto:erin.green@soundtransit.org)>; Tacoma Dome Link Extension <[tdlink@soundtransit.org](mailto:tdlink@soundtransit.org)>; Shively, Kevin <[Kevin.Shively@soundtransit.org](mailto:Kevin.Shively@soundtransit.org)>; Boudet, Brian <[BBoudet@cityoftacoma.org](mailto:BBoudet@cityoftacoma.org)>  
**Subject:** Comment on Home in Tacoma FEIS

Hi Alyssa,  
Attached find Sound Transit's comments on the Home in Tacoma FEIS. We appreciate the invitation to provide our thoughts and look forward to a future conversation on our comments.

Best, Diane

**Diane Wiatr, AICP**

HCT Development Manager – Tacoma Dome Link Extension  
Pronouns: she/her  
Capital Delivery Department  
Mobile 360-259-8001



**Sound Transit Values Start With Me & Start With You**  
Collaboration, Customer Focus, Inclusion & Respect, Safety, Integrity, Quality



September 24, 2024

Alyssa Torrez  
Senior Planner  
City of Tacoma  
733 Market Street, Room 11  
Tacoma, WA, 98402

**Subject: Home in Tacoma FEIS Comment by Sound Transit**

Dear Alyssa:

The City of Tacoma has issued and invited comments on the Final Environmental Impact Statement (FEIS) for Home in Tacoma, a package of code amendments including new zoning designations and development standards. Sound Transit supports the broad goals of Home in Tacoma to improve housing supply, choice, and affordability. However, **we respectfully request that the City refrain from amending bike parking requirements for rail transit stations in this package and allow time for the City and Sound Transit to define a shared approach to encourage and accommodate access to stations by bicycle.**

The proposed amendment would apply to the Portland Ave and Tacoma Dome (TDS) Stations on the Tacoma Dome Link Light Rail Extension (TDLE), requiring provision of parking to accommodate 5% of AM peak period boardings at each station (~180 bikes at TDS and ~20 bikes at Portland Ave).

Sound Transit shares the City's goal to encourage, facilitate, and grow access by bicycle. However, data on the utilization of bike parking at existing stations, and recent surveys of passengers who combine bikes and transit confirm that **this amendment would require provision of far more bike parking than could conceivably be used, even with substantial growth in cycling, and achievement of our shared vision for up to 5% of passengers to arrive at stations by bike.**

Planning to accommodate bikes at TDLE stations should include consideration of the following:

- System-wide, 2% of passengers access Sound Transit stations and services by bicycle.
- Average weekday utilization of existing secure bike lockers and bike rooms is 6.5% of capacity.
- The University of Washington Station has the highest average number of weekday bike locker rentals across the system (15), and the highest peak daily utilization in 2024 (22 bikes parked on 8/13/24).
- Low occupancy of existing bike parking at Sound Transit stations may be explained by the very high share (78%) of passengers accessing by bike who carry bikes on board the train (per ST data from Link stations [n=748] in June and July 2024), while just 11% use bike lockers, 7% lock to bike racks, and 2% use the secure bike storage rooms available at selected stations.
- 88% of Sound Transit passengers who carried their bikes on Link (n=427) reported doing so because they 'needed it to reach their final destination.'
- If the share of passengers arriving by bike reaches a target of 5% and the share of those carrying bikes on board holds constant at 78%, peak demand for parking would be for 40 bikes at TDS, and 4 at Portland Ave.

These passenger surveys and bike parking utilization data were collected, and projections made to inform a performance-based approach to the supply, management, and operation of bicycle parking across the system; all with a commitment to accommodate demand for passenger bike parking, when and where it arises.

In the next phase of TDLE planning, Sound Transit will conduct further analysis and projection of bike access mode share, as well as demand and will design options for integrating bike parking with stations. **If the City can separate this important topic of bike parking at transit stations from the Home in Tacoma package, Sound Transit stands ready to collaborate to define a shared, phased, and context sensitive approach**, including potential code amendments.

Sincerely,



Curvie Hawkins  
Tacoma Dome Link Extension, Project Development Director

cc: Brian Boudet, Division Manager, Planning and Development Services, City of Tacoma  
Diane Wiatr, Manager, High Capacity Transit Development, Sound Transit  
Erin Green, Acting Director, Environmental Planning, Sound Transit



**From:** Torrez, Alyssa  
**Sent:** Tuesday, September 24, 2024 3:21 PM  
**To:** City Clerk's Office  
**Subject:** FW: Comment on Home in Tacoma FEIS  
**Attachments:** ST\_Comment\_HomeInTacoma\_FEIS\_092424\_FINAL.pdf

Please see the comment for the public hearing that was received today.

Alyssa

---

**From:** Wiatr, Diane <diane.wiatr@soundtransit.org>  
**Sent:** Tuesday, September 24, 2024 1:49 PM  
**To:** Torrez, Alyssa <ATorrez@cityoftacoma.org>  
**Cc:** Hawkins, Curvie <Curvie.Hawkins@soundtransit.org>; Green, Erin <erin.green@soundtransit.org>; Tacoma Dome Link Extension <tdlink@soundtransit.org>; Shively, Kevin <Kevin.Shively@soundtransit.org>; Boudet, Brian <BBoudet@cityoftacoma.org>  
**Subject:** Comment on Home in Tacoma FEIS

Hi Alyssa,

Attached find Sound Transit's comments on the Home in Tacoma FEIS. We appreciate the invitation to provide our thoughts and look forward to a future conversation on our comments.

Best, Diane

**Diane Wiatr, AICP**

HCT Development Manager – Tacoma Dome Link Extension  
Pronouns: she/her  
Capital Delivery Department  
Mobile 360-259-8001



Sound Transit Values Start With Me & Start With You  
Collaboration, Customer Focus, Inclusion & Respect, Safety, Integrity, Quality



September 24, 2024

Alyssa Torrez  
Senior Planner  
City of Tacoma  
733 Market Street, Room 11  
Tacoma, WA, 98402

**Subject: Home in Tacoma FEIS Comment by Sound Transit**

Dear Alyssa:

The City of Tacoma has issued and invited comments on the Final Environmental Impact Statement (FEIS) for Home in Tacoma, a package of code amendments including new zoning designations and development standards. Sound Transit supports the broad goals of Home in Tacoma to improve housing supply, choice, and affordability. However, **we respectfully request that the City refrain from amending bike parking requirements for rail transit stations in this package and allow time for the City and Sound Transit to define a shared approach to encourage and accommodate access to stations by bicycle.**

The proposed amendment would apply to the Portland Ave and Tacoma Dome (TDS) Stations on the Tacoma Dome Link Light Rail Extension (TDLE), requiring provision of parking to accommodate 5% of AM peak period boardings at each station (~180 bikes at TDS and ~20 bikes at Portland Ave).

Sound Transit shares the City's goal to encourage, facilitate, and grow access by bicycle. However, data on the utilization of bike parking at existing stations, and recent surveys of passengers who combine bikes and transit confirm that **this amendment would require provision of far more bike parking than could conceivably be used, even with substantial growth in cycling, and achievement of our shared vision for up to 5% of passengers to arrive at stations by bike.**

Planning to accommodate bikes at TDLE stations should include consideration of the following:

- System-wide, 2% of passengers access Sound Transit stations and services by bicycle.
- Average weekday utilization of existing secure bike lockers and bike rooms is 6.5% of capacity.
- The University of Washington Station has the highest average number of weekday bike locker rentals across the system (15), and the highest peak daily utilization in 2024 (22 bikes parked on 8/13/24).
- Low occupancy of existing bike parking at Sound Transit stations may be explained by the very high share (78%) of passengers accessing by bike who carry bikes on board the train (per ST data from Link stations [n=748] in June and July 2024), while just 11% use bike lockers, 7% lock to bike racks, and 2% use the secure bike storage rooms available at selected stations.
- 88% of Sound Transit passengers who carried their bikes on Link (n=427) reported doing so because they 'needed it to reach their final destination.'
- If the share of passengers arriving by bike reaches a target of 5% and the share of those carrying bikes on board holds constant at 78%, peak demand for parking would be for 40 bikes at TDS, and 4 at Portland Ave.

These passenger surveys and bike parking utilization data were collected, and projections made to inform a performance-based approach to the supply, management, and operation of bicycle parking across the system; all with a commitment to accommodate demand for passenger bike parking, when and where it arises.

In the next phase of TDLE planning, Sound Transit will conduct further analysis and projection of bike access mode share, as well as demand and will design options for integrating bike parking with stations. **If the City can separate this important topic of bike parking at transit stations from the Home in Tacoma package, Sound Transit stands ready to collaborate to define a shared, phased, and context sensitive approach**, including potential code amendments.

Sincerely,



Curvie Hawkins  
Tacoma Dome Link Extension, Project Development Director

cc: Brian Boudet, Division Manager, Planning and Development Services, City of Tacoma  
Diane Wiatr, Manager, High Capacity Transit Development, Sound Transit  
Erin Green, Acting Director, Environmental Planning, Sound Transit

**From:** Newton, Corey  
**Sent:** Tuesday, September 24, 2024 3:34 PM  
**To:** City Clerk's Office  
**Cc:** Huffman, Peter; Boudet, Brian; Meredith, Linnea  
**Subject:** FW: TPAG Letter to be Sent to Council  
**Attachments:** TPAG Letter to Council Regarding HIT...pdf

Good Afternoon City Clerk's Office,

The Tacoma Permit Advisory Group has crafted the attached letter in regard to the Home in Tacoma legislation. I reached out to Susan and she recommended sending this letter to this email address to include this letter in the record for the public comment on Home in Tacoma. Please let me know if you have any questions.

Thanks,

**Corey Newton, P.E.**

Division Manager

Site and Building Division

City of Tacoma

Planning & Development Services

(253) 591-5765 Office

(253) 651-0278 Cell

We work with the community to plan and permit a safe, sustainable, livable city.

**[Take our survey!](#)**



**City Of Tacoma  
Tacoma Permit Advisory Group**

**ATTACHMENT**

---

**TO:** Tacoma City Council

**FROM:** Tacoma Permit Advisory Group

**SUBJECT:** Attachment letter concerning Home in Tacoma

**DATE:** September 18<sup>th</sup>, 2024

**CC:** Elizabeth Pauli, Melanie Harding, Peter Huffman

---

To the Tacoma City Council:

This letter was collectively drafted and approved by the Tacoma Permit Advisory Group (TPAG) to comment on the current Home in Tacoma package. For councilmembers unfamiliar with our group, the TPAG consists of builders, engineers, architects, and other housing industry professionals that will be working with Home in Tacoma on a daily basis once implemented.

We fully support Home in Tacoma and its goal of increasing affordable middle housing production. Unfortunately, after careful review, we believe the current Home in Tacoma package has several major problems that will significantly impair our ability to construct the affordable housing Home in Tacoma is intended to provide. For the sake of simplicity, we have narrowed our longer list of concerns previously sent to the Planning Commission down to the following three critical problems. Below each problem, we have summarized our proposed solution:

**Problem 1:** The proposed regulations will make it impossible to construct backyard buildings behind approximately 80-90% of existing houses due to pedestrian access requirements and a combination of other regulations (amenity space, FAR, setbacks, etc.). Ironically, it will become more difficult to build DADUs under Home in Tacoma than it is today.

**Recommended Solution:** Reduce pedestrian access requirements to the code minimum and apply other regulations solely to the backyard or side yard area being developed. This will open up thousands more sites for middle housing construction while allowing existing homes and front yards to remain unaltered, preserving neighborhood aesthetics.

**Problem 2:** Setbacks take up 44% of a standard 50'x120' site and 77% of a small 25'x100' site, which is an unacceptably inefficient use of space for middle housing projects. Similarly, rear height restrictions make townhome construction extremely impractical.

**Recommended Solution:** Reduce side and rear setbacks, reduce building separation requirements, and increase rear height limits. This will allow designs with more units and better layouts without dramatically increasing the bulk and scale of new structures when viewed from the street.

**Problem 3:** Tree retention requirements impair affordable housing development and exacerbate gentrification. Tree retention requirements also disincentivize owners from planting new trees in their yards because doing so will impair the value and future developability of their properties.

**Recommended Solution:** Remove tree retention requirements. If removing tree retention requirements is not an option, the Council can somewhat reduce these negative effects by providing an affordable fee-in-lieu option that doesn't require discretionary (variance or arborist) review.

We cannot overstate the importance of resolving these three problems. If the City Council does not resolve them, we believe that Home in Tacoma will largely fail in achieving its goal of increasing affordable housing production.

Please find attached a more detailed explanation of the three above issues. The attachment also includes detailed discussion of several second-tier issues that we believe are highly important but perhaps less critical than the three listed above.

We would welcome the opportunity to further explain our proposed changes in person at a study session or otherwise. Please don't hesitate to reach out with questions or concerns.

Thank you for your consideration.

Signed by:



4DCCEC082A08467...

**Justin Goroach**

Chair, Tacoma Permit Advisory Group

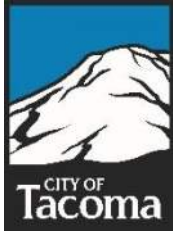

**City Of Tacoma  
Tacoma Permit Advisory Group**

**ATTACHMENT**

**TO:** Tacoma City Council  
**FROM:** Tacoma Permit Advisory Group  
**SUBJECT:** Attachment to letter concerning Home in Tacoma  
**DATE:** September 18th, 2024  
**CC:** Elizabeth Pauli, Melanie Harding, Peter Huffman

This letter has been drafted and unanimously approved by the Tacoma Permit Advisory Group. We previously sent a version of this letter to the City Council and Planning Commission in March, 2024. Unfortunately, the Planning Commission left many important issues unaddressed.

We strongly support Home in Tacoma’s goal of increasing affordable housing production. Unfortunately, the proposed regulatory package has six serious problems that stand in the way of that goal. If all of these problems are left unresolved, we believe affordable housing production may actually decrease after Home in Tacoma implementation. We implore the City Council to please fix these problems before it’s too late.

On a positive note, we believe that fixing most of these problems should be uncontroversial and simple. Below, we’ve summarized the six problems and provided a proposed solution to each. In the PDF version of this document, each heading below is a link to the corresponding subsection of this attachment:

**Problem 1: The proposed regulations make it impossible to construct backyard buildings behind approximately 90% of existing houses (around 82,000 lots citywide).**3

*Recommended Solution: Apply new regulations solely to the area of the property being developed and relax pedestrian egress requirements.* 5

**Problem 2: Setbacks take up 40-70% of most sites and the rear height restriction inhibits townhome construction** 7

*Recommended Solution: Reduce setbacks and rear height limit.* 9

**Problem 3: Tree retention requirements impair affordable housing development, create bad incentives, further inequality, and are not as good for the environment as might be expected.** 10

<i>Recommended Solution: Make tree retention optional.</i>	12
<b>Problem 4: Retention of existing parking requirements in the X-districts, downtown districts, and commercial districts is bad policy and may violate HB 1110.</b>	<b>13</b>
<i>Recommended Solution: Apply the transit parking exemption to all housing types, regardless of zoning.</i>	14
<b>Problem 5: Floor area ratio (FAR) requirements will needlessly impair affordable housing development if our other recommendations are adopted.</b>	<b>16</b>
<i>Recommended Solution: Eliminate FAR requirements</i>	16
<b>Problem 6: There is no efficient method to fix regulations that don't work as expected.</b>	<b>17</b>
<i>Recommended Solution: Empower the Planning Department to make temporary edits to code.</i>	17
<b>Exhibit A – Annotated test site plans</b>	<b>19</b>
<b>Exhibit B – Backyard building map overlays</b>	<b>20</b>

After reviewing this letter, we hope the City Council will formally adopt our solutions as revisions to the proposed Home in Tacoma regulations. We would be happy to present our solutions at a study session to provide more context.

Thank you for your consideration.

Signed by:



**Justin Goroch**

Chair, Tacoma Permit Advisory Group



## Problem 1: The proposed regulations make it impossible to construct backyard buildings behind approximately 90% of existing houses (around 82,000 lots citywide).

Tacoma’s proposed regulations will make it almost impossible to build additional units behind around 90% of existing houses. The two main issues are:

1. The pedestrian egress requirement (proposed code requires 8 ft side yard setback for egress)
2. That all other requirements apply to the entire lot, not just the area being developed (tree coverage, amenity space, parking, floor area ratio (FAR), and potentially stormwater filtration all apply to the entire lot, even when only the backyard is being developed).

As a result of these issues, very few existing houses can accept additional units. Below, we show how we reached this conclusion.

The following image is a site plan drawn by Tacoma’s consultant, Mithūn, in which they note that the backyard building “[c]onfiguration only works with a very shallow existing house”:

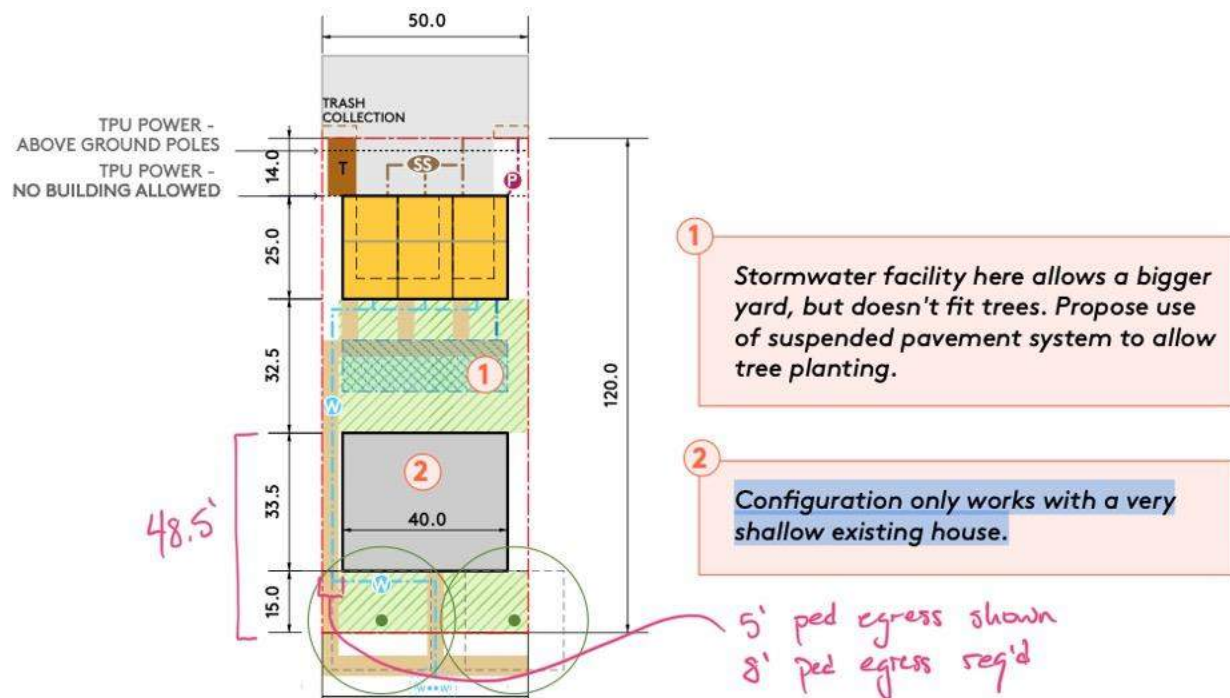

In other words, Mithūn can’t fit all the proposed site requirements (setbacks, amenity space, parking, tree canopy coverage, stormwater filtration, etc.) onto a standard lot unless the existing house ends about **48.5 ft** from the front boundary line and is also set back at least **8 ft** from one of the side boundary lines for pedestrian egress. Very few existing homes meet these requirements.

Exactly how few existing homes meet these requirements? We used aerial imaging to estimate that approximately 90% of existing homes extend beyond 48.5 ft from the front boundary. Below is a random screenshot of several blocks near Jefferson Park with a blue line superimposed at approximately 48.5 ft from the front boundary line. Any house that crosses this blue line would be unable to support a backyard unit per Mithūn’s findings. As you can see below, a maximum of about 15 of 120 lots shown (12.5%) would be able to accommodate additional units under this restriction (those sites are marked with red dots):



In other words, around 87.5% of the existing homes in the above-pictured neighborhood could not support an ADU-type structure under the proposed code. The outlook appears to be even worse in other neighborhoods where existing homes are larger or set further back from the front boundary. We have attached several screenshots of random neighborhoods around Tacoma as **Exhibit B** to this attachment.

This issue only gets worse when considering the 8 ft side yard setback issue, which we believe (anecdotally) affects 30-50% of Tacoma’s existing houses. In some neighborhoods, it’s possible that only 5% of existing properties could accept backyard units under the proposed regulations.

## Recommended Solution: Apply new regulations solely to the area of the property being developed and relax pedestrian egress requirements.

Our recommended solutions consist of several elements:

1. Only apply the new setback, tree coverage, amenity space, stormwater filtration, parking, and FAR requirements (if any) to the redeveloped portion of the lot and not to the portion of the lot containing the existing house as illustrated below:

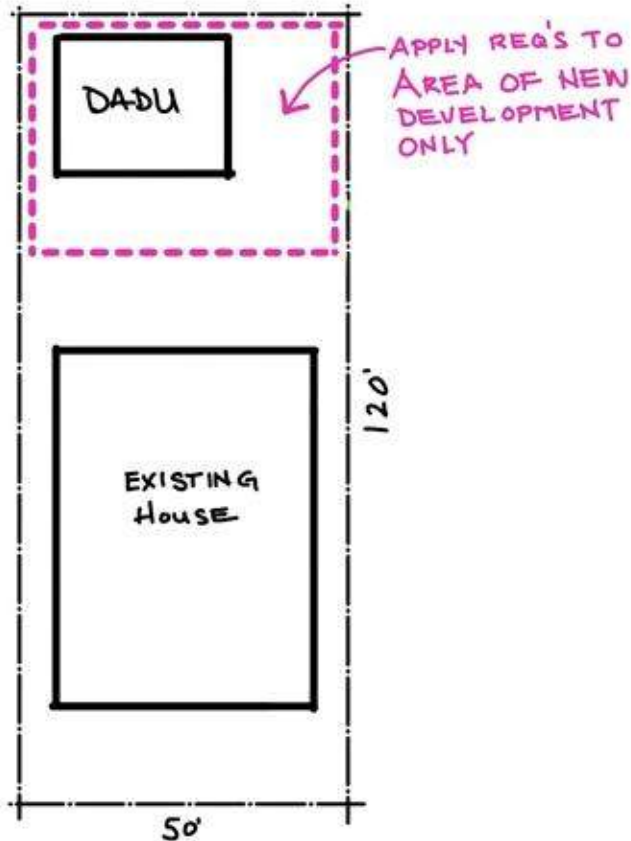

2. Eliminate minimum pedestrian path widths (building code minimum widths would still apply to allow safe emergency access).
3. Eliminate pedestrian path requirements entirely when existing homes are constructed within 3 ft of both side property lines if: (a) the backyard units have alley-loaded parking, *and* (b) the backyard units have sufficient alley access for emergency vehicles.

### Advantages of these recommended solutions:

1. As written, Tacoma's proposed regulations will leave approximately 90% of existing lots with no potential for backyard units. Our recommended solution will make backyard units viable on most lots without the need to tear down existing homes.
2. The recommended solution will result in more existing structures being retained, more affordable housing development, and a larger net contribution to the city's housing and tree canopy goals through increased development.

**Possible criticisms of these recommended solutions:**

1. We believe this recommendation should be relatively uncontroversial. In an ideal world, the city would probably like to see old sites fully comply with modern requirements. However, that's infeasible on the vast majority of old sites without removing existing heritage buildings. We believe our solution offers a sensible middle-ground where heritage buildings don't need to be dramatically altered or removed to accommodate new development. When heritage buildings reach the end of their useful life, they can be redeveloped according to then-current code, bringing the entire site into compliance.

## Problem 2: Setbacks take up 40-70% of most sites and the rear height restriction inhibits townhome construction

Setbacks are the minimum allowed distance between a property line and a building envelope. Most residential properties in Tacoma will be subject to the following proposed setbacks applicable in the UR-1 zone (without bonusing):

- Front: 15 ft
- Rear: 15 ft
- Side: 5 ft or 8 ft with pedestrian egress (discussed in previous section)
- Building separation: 10 ft

These large setbacks are perhaps the single biggest blow to developability. As shown below, the proposed setbacks wipe out around 44% of a standard site, reducing it from 6,000 sf (measuring 50 ft x 120 ft) to a maximum buildable area of 3,330 sf (measuring 37 ft x 90 ft).

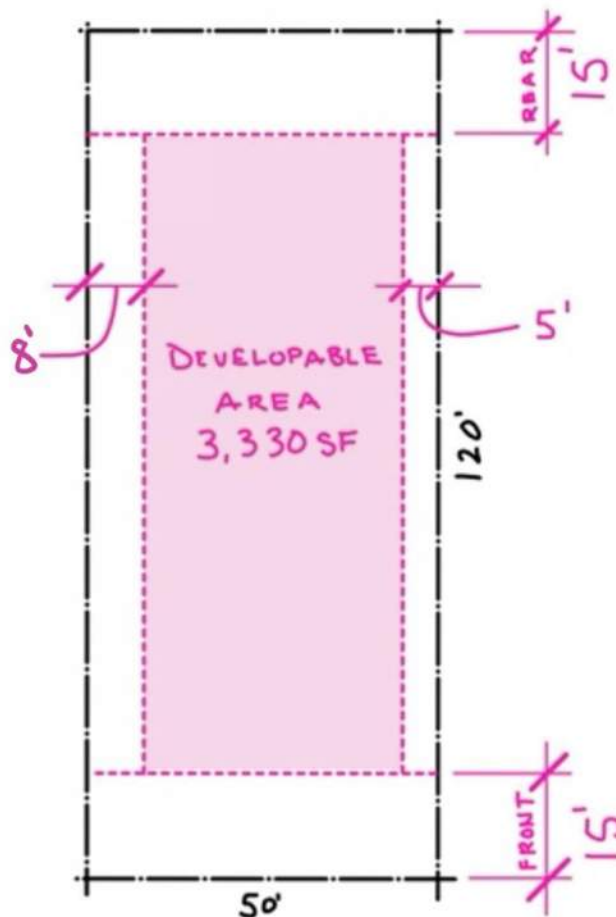

The numbers get much worse on smaller sites. On a 2,500 sq ft site (measuring 25 ft x 100 ft), these setbacks **would wipe out 77% of the site**, leaving a maximum buildable area of just 840 sf measuring 12 ft x 70 ft (far too narrow for a healthy floorplan).

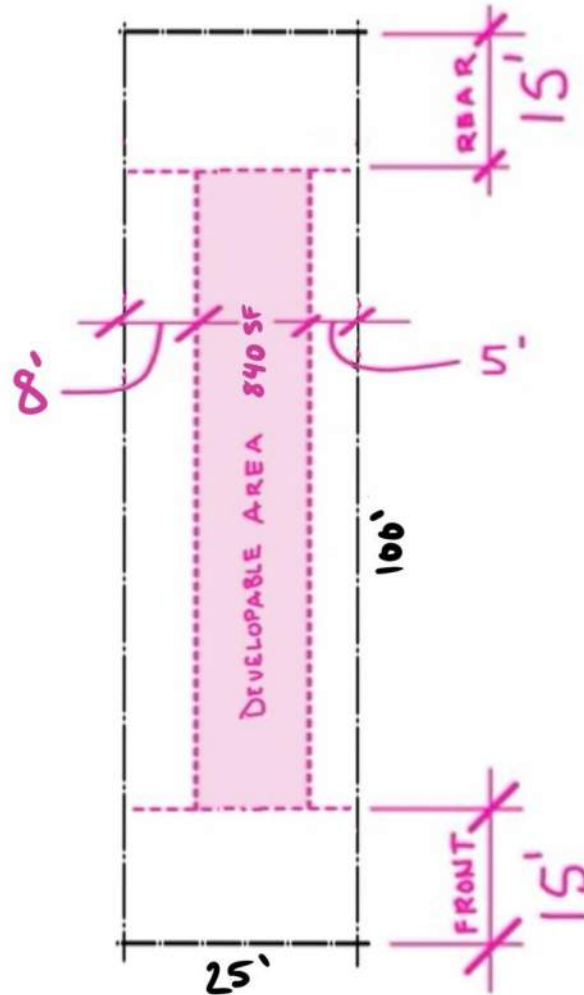

Similarly, the city has imposed a 25 ft height restriction on the rearmost 25 ft of UR-1 and UR-2 lots. This makes it impossible to build a third story adjacent to the alley. This is bad for all housing types, but it's particularly bad for townhomes and backyard buildings, which typically feature a garage on the ground floor and two stories of living space above. Townhome construction will not be viable if this regulation remains unchanged.

Please note that these setbacks and height restrictions are purely about aesthetics, not safety. The building code already includes requirements for fire separation and emergency access (e.g., IRC table R302.1-2).

## **Recommended Solution: Reduce setbacks and rear height limit.**

Tacoma's setback requirements take up more of a developable lot than any other single proposed requirement. Therefore, we recommend that Tacoma reduce or eliminate setbacks as follows:

- Front: No change for mid-block lots. For corner lots, 0' setback (see below).
- Rear: 0 ft
- Side: 3 ft for UR-1 and UR-2, 0 ft for UR-3
- Building separation: 5 ft

We are not recommending a change to Tacoma's proposed front setback for mid-block lots because we believe the front setback is the most important setback for neighborhood character, bulk, and scale compatibility.

However, we do recommend elimination of the front setback for corner lots to facilitate corner stores or small at-home businesses on the corner (e.g., attorney or other professional), which are uses allowed with Home in Tacoma. As part of this proposal, corner lots should be allowed to orient the building towards either (or both) frontages at the election of the property owner, especially if there is an existing building oriented towards the long side of the property (which is considered by Tacoma Planning to be the side rather than the front).

Likewise, we recommend that the city eliminate the 25 ft rear height restriction to allow efficient townhome layouts situated towards the rear of the lot.

### **Advantages of these recommended solutions:**

1. Dramatically increases developable area without having much impact on the bulk or scale appearance of the new structure from the street.
2. Help facilitate neighborhood business uses on corners (the classic "corner store" or neighborhood professional).

### **Possible criticisms of these recommended solutions:**

1. We believe these recommendations should be fairly uncontroversial. Aesthetically, some people prefer to see buildings set back further from the side property lines and alleys. However, we don't believe these aesthetic considerations are worth the trade-off of eliminating 44-77% of a site's developable area. We hope our recommendation strikes the right balance between aesthetic preferences and missing middle housing production.

## **Problem 3: Tree retention requirements impair affordable housing development, create bad incentives, further inequality, and are not as good for the environment as might be expected.**

Tacoma's proposed regulations require owners to retain existing trees larger than 12 inches in diameter except with permission from the city. Trees larger than 18 inches can't be removed without a variance and an arborist's report, which is an expensive, time-consuming, and uncertain process. Even if when the city grants permission to remove trees, owners will be required to pay a canopy loss fee of \$125 per inch, which equates to around \$3,000 per tree for a 24-inch tree. On a heavily treed site, these costs can add up to tens of thousands of dollars.

There are four main downsides to these tree retention requirements, as outlined below.

### **Impact on missing middle housing development**

Tree retention requirements dramatically limit development potential and increase costs. If developers must pay to remove trees, those costs get passed on to homebuyers and renters. If developers are unable to remove trees, they will need to reduce unit count or cut square footage out of their designs to fit the site. This increase design costs (which are passed onto the buyer or renter) and many projects may be entirely infeasible.

### **Furthering existing inequalities**

Counterintuitively, tree retention requirements will further existing inequalities by forcing affordable housing development out of Tacoma's wealthier and more heavily treed areas. As explained above, tree retention requirements make development impossible or expensive in heavily treed neighborhoods. These requirements will push affordable housing development out of the wealthier and more heavily treed areas (the North End, the North Slope, and Northeast Tacoma) and into disproportionately poorer areas with fewer existing trees (Hilltop, Central Tacoma, and the South End). This will exacerbate gentrification, displacement, and further existing inequality by keeping affordable housing out of Tacoma's wealthiest neighborhoods.

While some tree retention advocates seem sincere in their concern for Tacoma's trees, some advocates seem to be using tree retention as a last-ditch effort to resist development in Tacoma's wealthy neighborhoods. Many of the same people who initially opposed Home in Tacoma and who advocated for the College Park Historic District now support tree retention requirements because doing so will ensure that their neighborhoods can continue to exclude development.



## Creating bad incentives for discretionary tree planting

Tree retention creates bad incentives by punishing the following behaviors we should be encouraging:

1. We should be rewarding owners for contributing to the urban tree canopy by planting trees around their existing homes. Instead, tree retention requirements penalize owners for planting trees by reducing their property values and the development potential of their land. Fewer owners will choose to plant trees around their existing homes as a result.
2. On a similar note, many owners will clearcut their properties ahead of implementation of these tree retention requirements to avoid diminished development potential. If not for an impending tree retention requirement, many of these trees might otherwise remain for years or decades until the properties are ripe for redevelopment.
3. Unscrupulous owners will circumvent tree retention requirements by illegally poisoning trees and then having an arborist declare them dead or hazardous. There's generally no reliable way to detect poisoning, so only law-abiding owners are likely to suffer from tree retention restrictions.

## Younger trees have a carbon sequestration advantage over older trees

Lastly, retention of mature trees is less environmentally friendly than one might expect. Recent studies have concluded that, per stand, young trees are much better at carbon sequestration than mature trees, perhaps due to increased growth rate during youth. See the following graph reflecting a dramatic drop-off in carbon sequestration after around 40 years of life for native Pacific Northwest tree species:

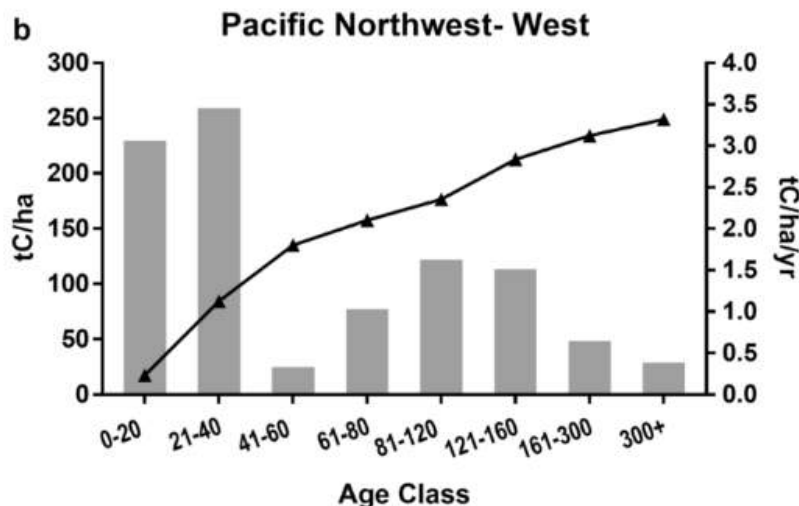

Citation: Hoover, C.M., Smith, J.E. Aboveground live tree carbon stock and change in forests of conterminous United States: influence of stand age. Carbon Balance Manage 18, 7 (2023).

<https://doi.org/10.1186/s13021-023-00227-z>

We don't mean to imply that mature trees aren't beneficial or beautiful. Mature trees likely do more than young trees to reduce the urban heat island effect, improve water filtration, and provide urban habitat. However, because young trees have a distinct advantage when it comes to improving air quality (carbon sequestration), it's not clear the city should be prioritizing mature tree retention at the cost of the major downsides noted above.

## **Recommended Solution: Make tree retention optional.**

We recommend making tree retention optional (except in the right-of-way) while keeping retention incentives.

As a middle ground, the city could also consider leaving the canopy loss fee as a disincentive to tree removal. In other words, owners would not need to ask for permission to cut down trees, but they would still need to pay a certain fee per inch if they chose to do so. This policy has the advantages of predictability and consistency. However, this policy still has the other downsides mentioned above, like increasing housing costs for buyers and renters, penalizing discretionary tree planting, incentivizing unscrupulous behavior by owners, adding complexity to the permitting process, and disincentivizing development in wealthier, more heavily treed, neighborhoods. The more costly the removal fee, the greater these risks.

### **Advantages of eliminating tree retention requirements and canopy loss fees:**

1. Eliminate the incentive for property owners to quickly clearcut existing trees before tree retention requirements take effect.
2. Eliminate inequitable neighborhood impacts resulting from existing disproportionate canopy coverage (more development in areas with less existing tree canopy).
3. Eliminate the disincentive for property owners to avoid planting trees around existing homes for fear that those trees may eventually pose an impediment to future development.
4. Increase carbon sequestration by requiring new tree plantings rather than retaining mature trees that sequester less carbon.
5. Increase housing production dramatically.
6. Increase permitting consistency, predictability, and speed.
7. Increase the ease of code administration for staff.

### **Possible criticisms of this recommended solution:**

1. Fewer mature trees will be retained, which may increase urban heat island and decrease habitat (at least until newly planted trees mature). We don't take the loss of mature trees lightly, but we do see it as a worthwhile trade-off when considering the benefits (more carbon sequestration, more housing production, no last-minute clearcutting, no disincentive for planting around existing structures, etc.).

## Problem 4: Retention of existing parking requirements in the X-districts, downtown districts, and commercial districts is bad policy and may violate HB 1110.

Huge swaths of the new Urban Residential zones will have no parking requirement due to their proximity to transit. This is due to the requirement in HB 1110 that missing middle housing types shall not be required to provide parking within one-half mile of a major transit stop. However, the proposed regulations leave the existing parking requirements in the X-District, Downtown District, and Commercial zones, meaning that residential developments in those areas must provide for up to one stall per unit regardless of their proximity to a major transit stop.

The below map shows the areas exempt from parking due to proximity to transit. Notice that the X-District, Downtown District, and Commercial zones (outlined in purple) remain unshaded (i.e., not exempt from parking):

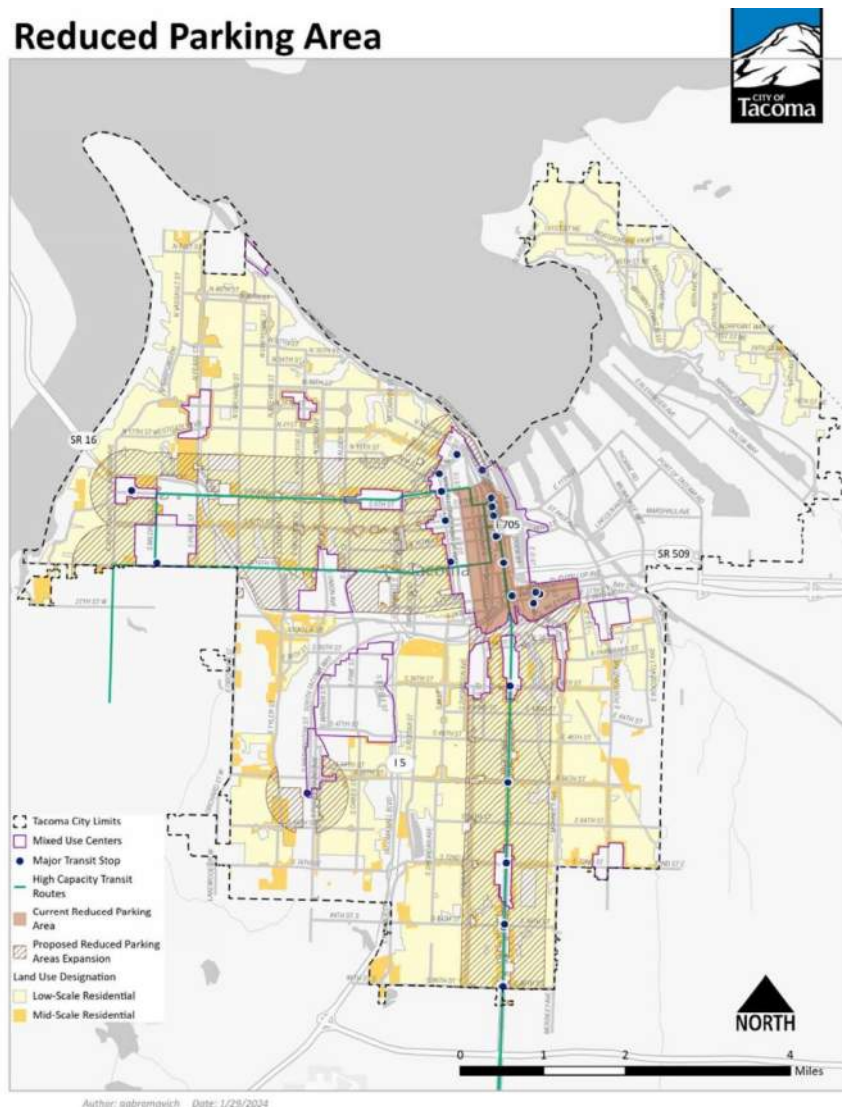

There are two problems with not exempting these zones from parking requirements. First, it's contrary to good policy because the X-District, Downtown District, and Commercial zones are intended to be denser than the adjacent Urban Residential zones. By eliminating parking only in the Urban Residential zones, the city will be pushing development out of the supposedly denser X-District, Downtown District, and Commercial zones and into residential areas.

Second, we believe it's illegal under state law for Tacoma not to apply the transit parking exemption to middle housing in these zones. We have already raised this point with City Attorney's Office and are awaiting response. However, in brief, HB 1110 requires cities to exempt all middle housing from parking requirements within one half-mile of a major transit stop, regardless of zoning. Below is the relevant section:

(6) Any city subject to the requirements of this section [including Tacoma]:

...

(d) Shall not require off-street parking as a condition of permitting development of *middle housing* within one-half mile walking distance of a major transit stop

Thus, it does not matter under HB 1110 whether the missing middle housing is located in an X-District, Downtown District, or Commercial zone—all missing middle housing is exempt from parking requirements if it is built within one-half mile of a major transit stop.

## **Recommended Solution: Apply the transit parking exemption to all housing types, regardless of zoning.**

For the sake of consistency and compliance with state law, Tacoma should apply the transit parking exemption to all middle housing within one-half mile of a major transit stop, regardless of where it's located.

### **Advantages of this recommended solution:**

1. This proposal enhances parking requirement consistency citywide, ensuring that the new Urban Residential districts don't become more densely developed than the X-District, Downtown District, and Commercial zones that are intended to provide more density.
2. This proposal ensures compliance with state law.

### **Possible criticisms of this recommended solution:**

1. Planning staff seemed to generally agree that our proposal made sense from a consistency standpoint. However, staff expressed concern that altering parking requirements within the X-District, Downtown District, and Commercial zones is outside the purview of Home in Tacoma, which was not intended to alter non-residential zones. This argument rings hollow for two reasons:
  - a. First, Home in Tacoma is already altering parking requirements in these zones by eliminating the existing parking exemption for units 450 sq ft and smaller. This is a big blow to residential developability in these zones, as many of the big apartment projects in recent years have relied on this exemption. It's inconsistent

to argue that Home in Tacoma isn't allowed to alter these zones when it already proposes to do so.

- b. Second, these zones should be considered residential. The X-district zones (particularly URX and RCX) are by definition primarily residential with limited commercial allowed.

## **Problem 5: Floor area ratio (FAR) requirements will needlessly impair affordable housing development if our other recommendations are adopted.**

Floor area ratio (FAR) is the measurement of a building's floor area in relation to the size of the lot on which the building is located. Under Tacoma's proposed regulations, the FAR requirements are mostly redundant. Almost any development that would comply with the proposed setback, amenity space, and tree canopy requirements would also comply with FAR restrictions.

However, if the city adopts our recommended solutions set out above, the existing FAR limits will become a significant limiting factor without adding much to bulk and scale compatibility.

### **Recommended Solution: Eliminate FAR requirements**

#### **Advantages of this recommended solution:**

1. Eliminate redundant requirement and allow additional development.
2. Ease the difficult for staff of administering this increasingly complex code.

#### **Possible criticisms of this recommended solution:**

1. Some of the criticisms noted in other sections may apply here too. No other criticisms known.

## **Problem 6: There is no efficient method to fix regulations that don't work as expected.**

It's almost impossible for a sweeping municipal code change like Home in Tacoma to be perfect on the first attempt. As we've noted, the current draft has many unexpected consequences and serious problems that will undermine affordable housing production. Even if each the problems we've noted here are resolved, there are probably many latent problems that will surface after implementation.

Ordinarily, these unforeseen problems could only be resolved by passing code changes through the City Council. However, this is a slow and clunky process, especially for minor tweaks that may only affect a handful of properties.

### **Recommended Solution: Empower the Planning Department to make temporary edits to code.**

To provide a more expedient alternative, we ask that the Planning Department be empowered with discretion to relax regulations that aren't working as expected. This discretion should be subject to the following limitations:

1. In general, this discretion should only be used when the regulations are unclear, or have unforeseen consequences, or render missing middle housing construction infeasible.
2. This discretion shall only apply to residential projects (including those in the commercial, downtown, and x-district zones).
3. The discretion cannot be used to increase regulations, complicate permitting, add costs, or otherwise inhibit housing production.
4. All discretionary changes must be universally applied and published on the city's website so that no individual owner obtains a unique benefit.
5. At regular intervals (perhaps once every six months), the list of discretionary changes must be brought before the City Council for review, approval or disapproval, and codification.

The purpose of our suggested solution is to provide an expedient and flexible way to patch unforeseen problems without waiting for City Council to act. Notably, this recommended solution is broader than a variance because a variance does not empower planning staff to implement policy changes affecting multiple properties. It will also be fairer and more efficient than a variance because once a policy is changed, it applies to all properties and no individual owner will obtain a unique benefit.

#### **Advantages of this recommended solution:**

1. Staff can rapidly patch unforeseen code problems, which will allow more predictable and affordable construction.
2. The City Council will review these patches at regular intervals to assure they align with the council's goals.

**Possible criticisms of this recommended solution:**

1. Planning staff could theoretically relax development regulations too much and the City Council may not catch the issue until the next scheduled review date. However, in our experience, planning staff isn't inclined to recklessly facilitate development. We think the risk of abuse is very low compared to the risk of allowing unforeseen regulatory consequences to persist for months or years pending a fix from the City Council.



## **Exhibit A – Annotated test site plans**

This exhibit consists of our rough annotations of consultant Mithūn’s test site plans. These annotations were initially created by the Tacoma Permit Advisory Group to illustrate issues to Planning Department staff. Note you will notice the same site plan multiple times because there are multiple pages of annotations for the several plans (e.g., #1A, #3A, and #3B).

## **Exhibit B – Backyard building map overlays**

This exhibit shows the backyard building potential of several additional neighborhoods around Tacoma, selected at random. As noted by Mithūn, backyard buildings generally won't fit if the existing house extends beyond around 48.5 ft from the front property line. In this exhibit, we have superimposed lines at approximately 48.5 ft from the front property line. The vast majority of existing homes extend beyond this line, making them ineligible for backyard buildings.

Note that many of the lots in the following images are smaller than a standard lot that Mithūn used in creating these site plans (6,000 sq ft, measuring 50 ft x 120 ft). Therefore, the proposed regulations may prohibit even more backyard development than it appears from the following images.

# #1A Retain House + 3-Unit Backyard Building

## Building Data

- UR-1, 6000 sf lot
- FAR: 0.8, BYB\* 3,000 GSF, 3 stories
- BYB unit size: 1,000 SF

## Access & Parking

- Alley-loaded
- 3 surface parking stalls
- In-unit bike parking

Note: \* BYB = Backyard Building

## Amenity Space

- Ground level amenity space: 2,180 SF
- Amenity space min: 1,200

## Tree Credits

- Tree credit shown: 2,200
- Tree credit min.: 2,100
- Can meet soil volume without SPS  
Greatest soil depth to meet volume requirements: 3.5'

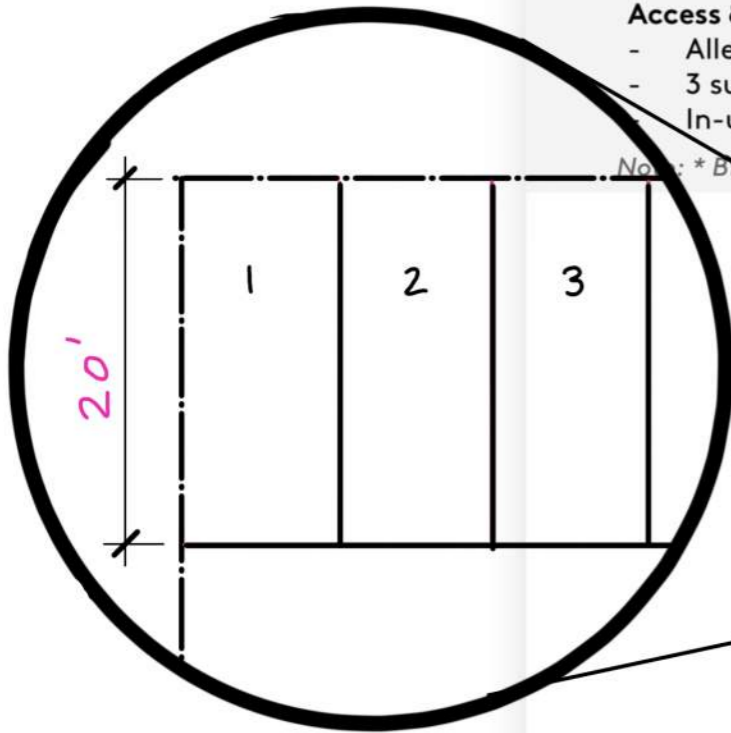

WHEN PARKING ADJACENT TO AN ALLEY, PARKING HAS BEEN 20' DEEP MINIMUM.

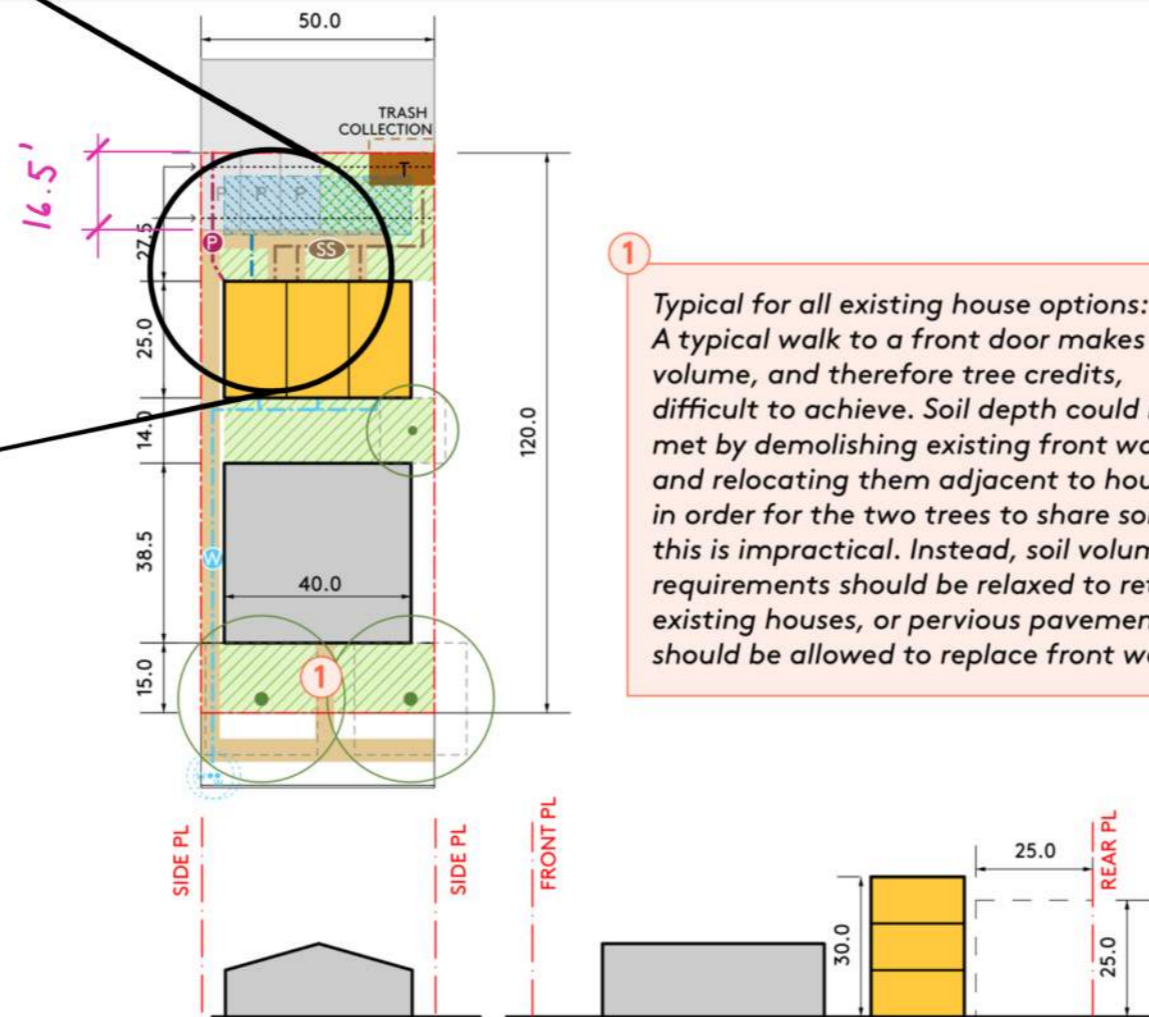

1 Typical for all existing house options: A typical walk to a front door makes soil volume, and therefore tree credits, difficult to achieve. Soil depth could be met by demolishing existing front walks and relocating them adjacent to houses in order for the two trees to share soil, but this is impractical. Instead, soil volume requirements should be relaxed to retain existing houses, or pervious pavement should be allowed to replace front walks.

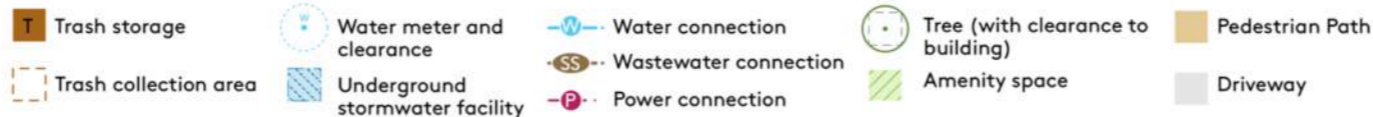

# #1A Retain House + 3-Unit Backyard Building

## Building Data

- UR-1, 6000 sf lot
- FAR: 0.8, BYB\* 3,000 GSF, 3 stories
- BYB unit size: 1,000 SF

## Access & Parking

- Alley-loaded
- 3 surface parking stalls
- In-unit bike parking

Note: \* BYB = Backyard Building

## Amenity Space

- Ground level amenity space: 2,180 SF
- Amenity space min: 1,200

## Tree Credits

- Tree credit shown: 2,200
- Tree credit min.: 2,100
- Can meet soil volume without SPS  
Greatest soil depth to meet volume requirements: 3.5'

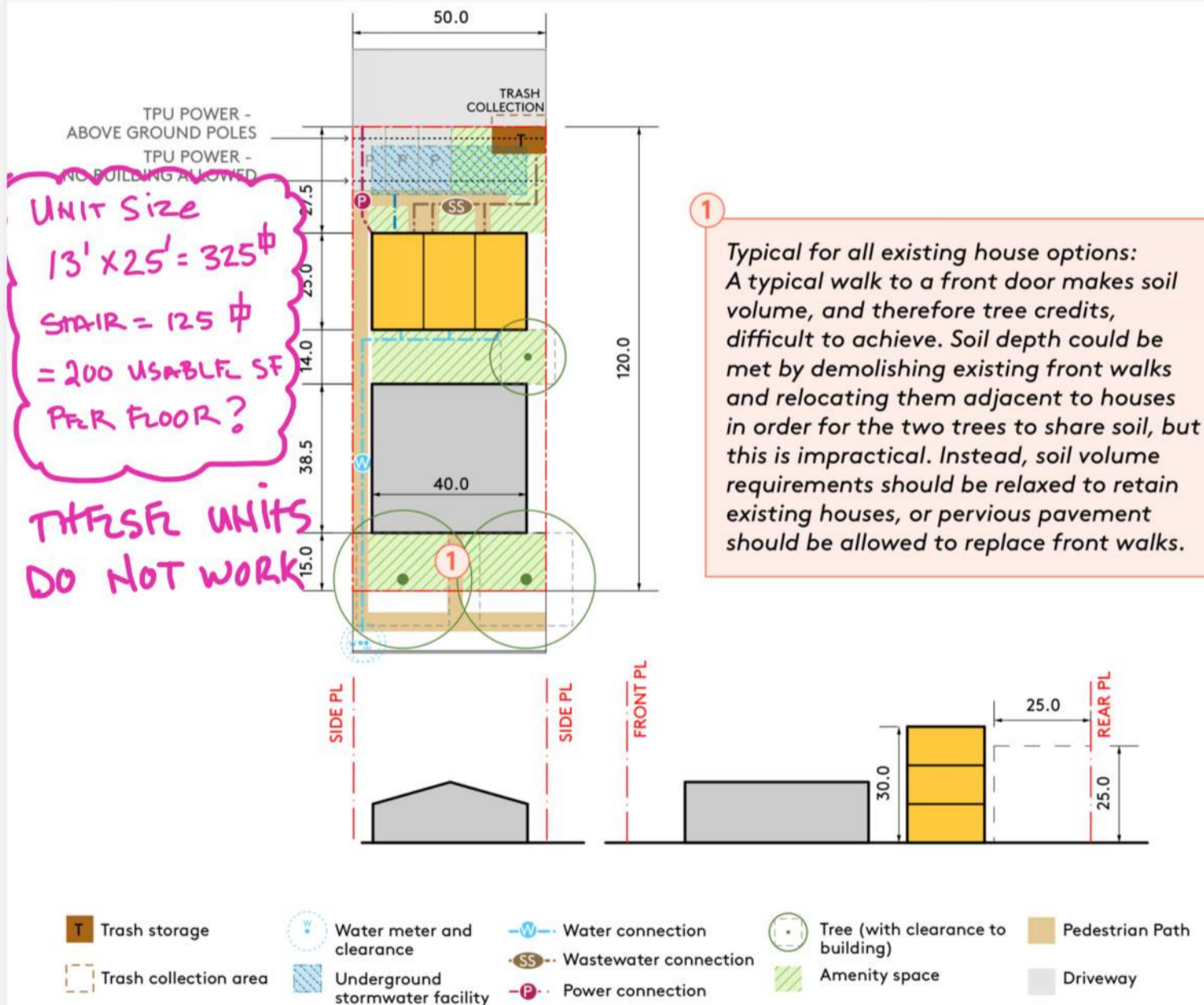

# #1B Retain House + 3-Unit Backyard Building

## Building Data

- UR-1, 6000 sf lot
- FAR: 0.7, BYB\* 2,560 GSF, 2.5 stories
- BYB unit size: 650 SF

## Access & Parking

- Alley-loaded
- 3 parking spaces in garages
- In-unit bike parking

Note: \* BYB = Backyard Building

## Amenity Space

- Ground level amenity space: 2,180 SF
- Amenity space min: 1,200

## Tree Credits

- Tree credit shown: 2,000
- Tree credit min.: 2,100
- Does not meet tree credits

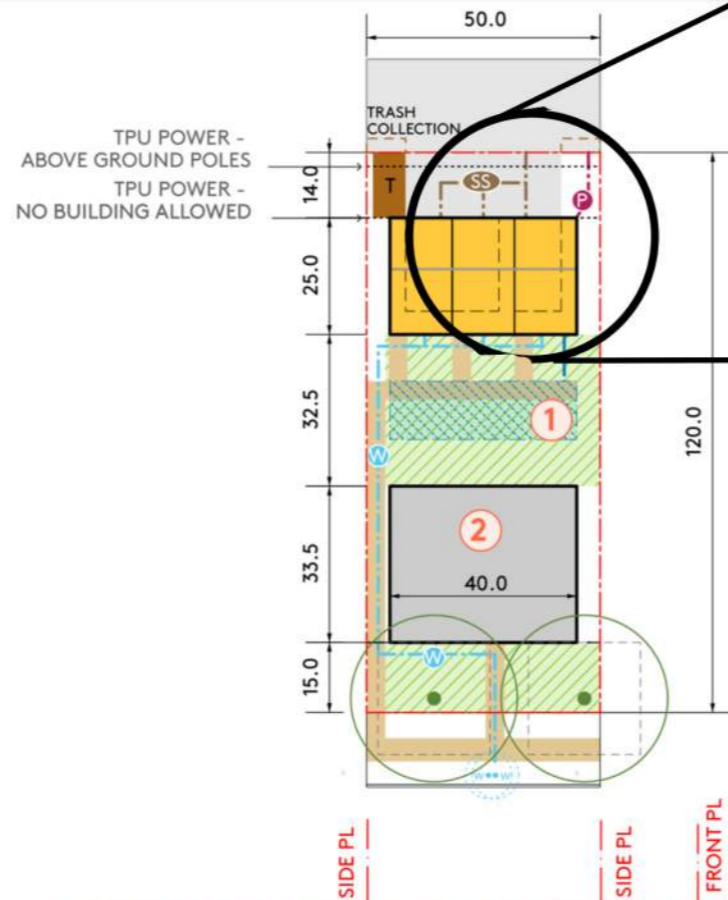

- 1 Stormwater facility here allows a bigger yard, but doesn't fit trees. Propose use of suspended pavement system to allow tree planting.
- 2 Configuration only works with a very shallow existing house.

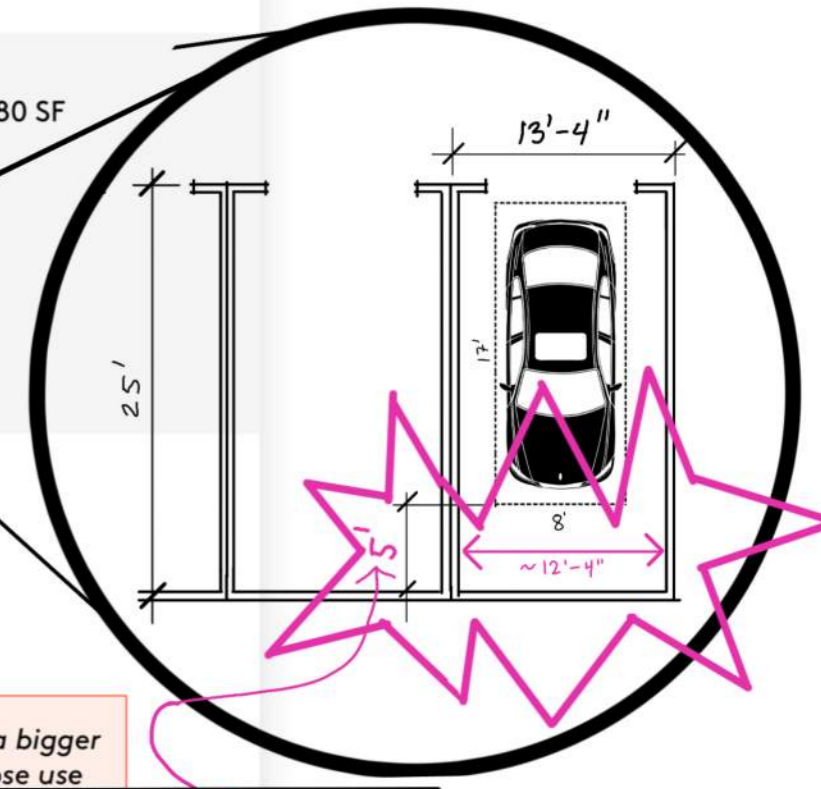

NEED SPACE FOR A STAIR

\*NOTE: A WORKABLE WIDTH FOR A MULTISTORY UNIT IS 17'-18' WIDE AND 30' LONG. IT CAN BE DONE W/ LESS BUT RECOMMEND BUILDING IN... SOME FLEXIBILITY

13' wide garage townhomes: 1B and 1C show 13'x30' units with a parking stall and "in-unit bike parking." Is it feasible to package a parking stall, bike parking, and a staircase (out of the garage up to 1<sup>st</sup> floor) all within a 13'x30' area?

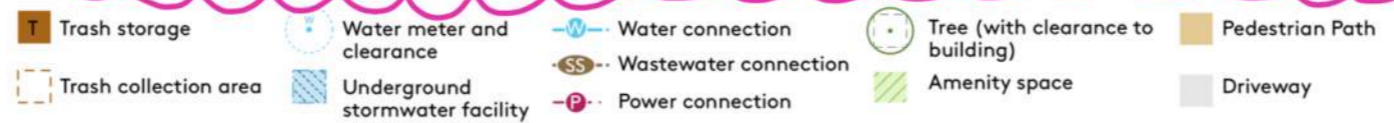

# #1C Retain House + 3-Unit Backyard Building

## Building Data

- UR-1, 6000 sf lot
- FAR: 0.7, BYB\* 3,000 GSF, 3 stories
- BYB unit size: 1,000 SF

## Access & Parking

- Street-loaded
- 3 parking spaces in garages
- In-unit bike parking

Note: \* BYB = Backyard Building

## Amenity Space

- Ground level amenity space: 1,300 SF
- Amenity space min: 1,200

## Tree Credits

- Tree credit shown: 1,900
- Tree credit min.: 2,100
- Does not meet tree credits <sup>2</sup>

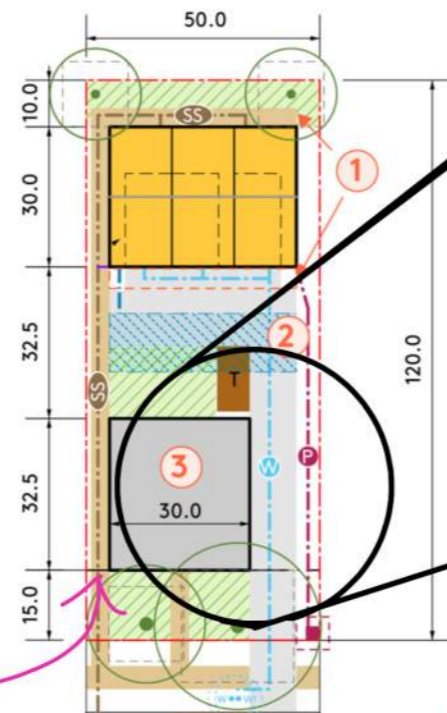
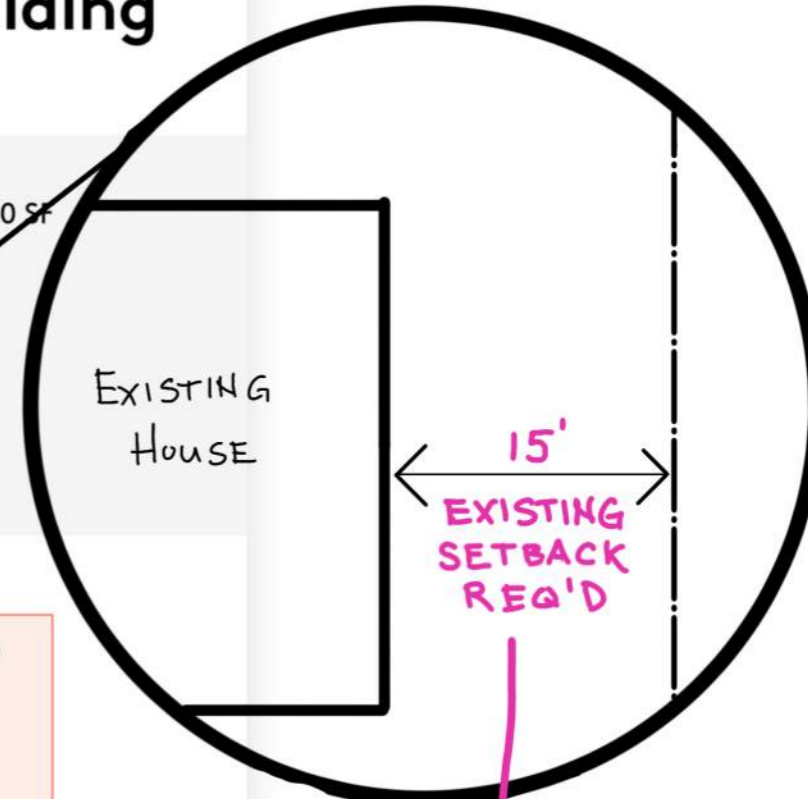

<sup>1</sup> Requirement for separated pedestrian and auto access puts rear sidewalks too close to building and negates private yards for the units. Discuss moving sidewalk to cross driveway.

<sup>2</sup> Stormwater facility here allows a bigger yard, but doesn't fit trees. Propose use of suspended pavement system to allow tree planting.

<sup>3</sup> Configuration only works with a shallow existing house with a sideyard large enough for a driveway.

MISSING 8' REQ'D WALKWAY WHEN SERVING BACKYARD UNITS

**Small existing homes:** 1A, 1B, and 1C all picture small existing homes with very specific footprints/positions on the lot. 1C is the worst, as the existing home would need to be about 900 sf and must be positioned about 15' from one property line (to accommodate driveway and power) and 8' away from the other property line (for pedestrian egress). What proportion of existing homes fit these parameters? My guess is less than 5%--probably much less.

**Forgotten sewer:** 1A, 1B, and 1C don't show sewer from the existing home. How would this affect the drawings? In 1A, I believe it would wipe out a tree.

# #2 4-Unit Houseplex (Deep Townhouses)

## Building Data

- UR-1, 6000 sf lot
- FAR: 0.8, 4800 GSF, 2.7 stories
- Unit size: 1,200 SF

## Access & Parking

- Alley-loaded
- 4 parking spaces in garages
- In-unit bike parking

## Amenity Space

- Ground level amenity space: 2,050 SF
- Amenity space min.: 1,200

## Tree Credits

- Tree credit shown: 2,200
- Tree credit min.: 2,100
- Can meet soil volume without SPS  
Greatest soil depth to meet volume requirements: 2.4'

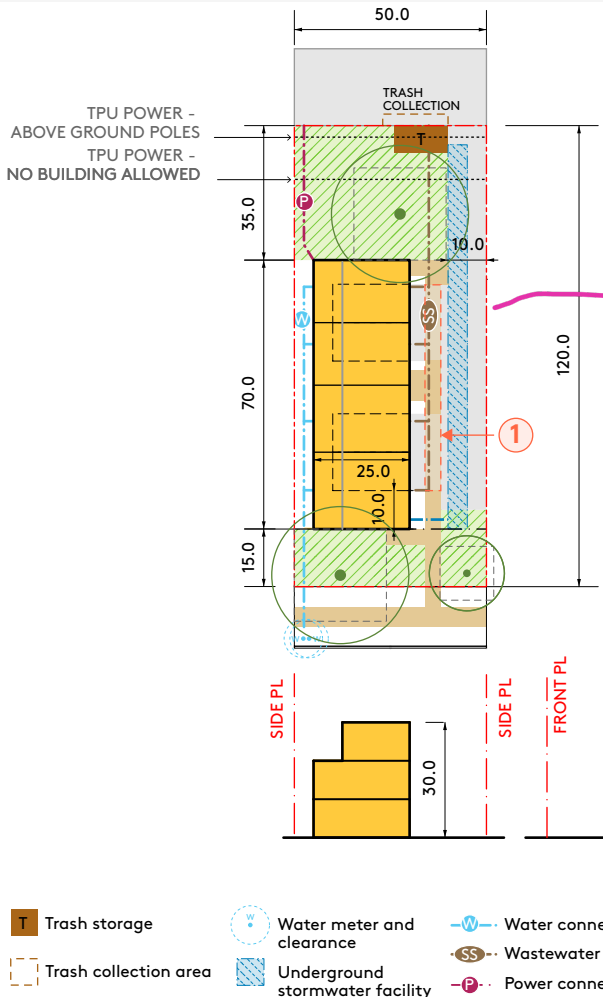

① This configuration assumes that pedestrian paths are allowed to cross driveways in order to avoid dedicating other side yard to entries which would require more setback and make a skinnier building.

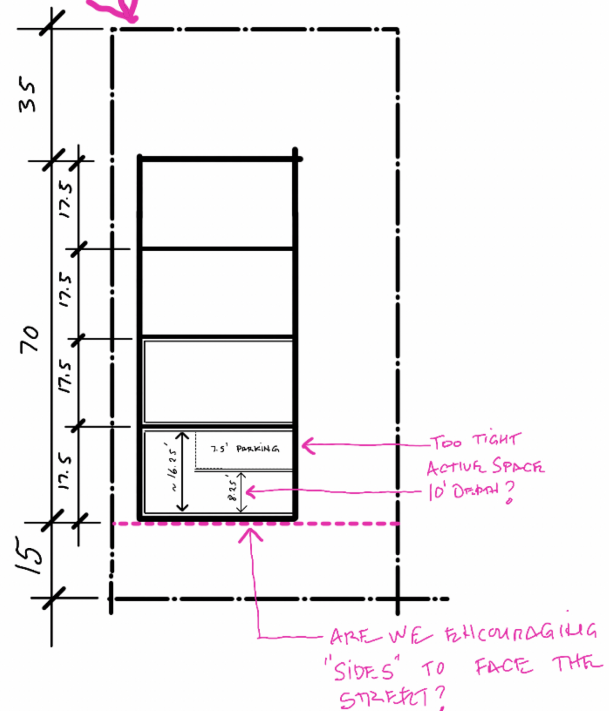

# #3A 6-unit Houseplex (Deep Townhouses)

## Building Data

- UR-1 with bonus, 6000 sf lot
- FAR: 1.0, 6,000 GSF, 2.5 stories
- Unit size: 1,000 SF

## Access & Parking

- Alley-loaded
- 4 surface parking stalls (including one accessible stall)
- 2 in-unit bike parking; 2 spaces in bike lockers

## Amenity Space

- Ground level amenity space: 1,570 SF
- Amenity space min: 1,800

## Tree Credits

- Tree credit shown: 2,200
- Tree credit min.: 2,100
- Can meet soil volume without SPS
- Greatest soil depth to meet volume requirements: 2.6'





# #3A 6-unit Houseplex (Deep Townhouses)

## Building Data

- UR-1 with bonus, 6000 sf lot
- FAR: 1.0, 6,000 GSF, 2.5 stories
- Unit size: 1,000 SF

## Access & Parking

- Alley-loaded
- 4 surface parking stalls (including one accessible stall)
- 2 in-unit bike parking; 2 spaces in bike lockers

## Amenity Space

- Ground level amenity space: 1,570 SF
- Amenity space min: 1,800

## Tree Credits

- Tree credit shown: 2,200
- Tree credit min.: 2,100
- Can meet soil volume without SPS
- Greatest soil depth to meet volume requirements: 2.6'

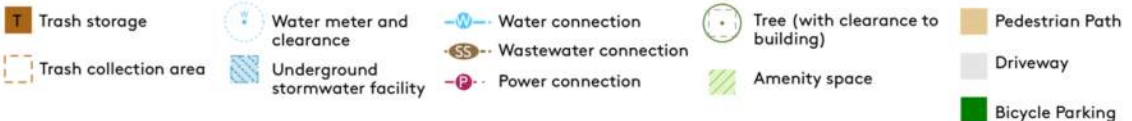
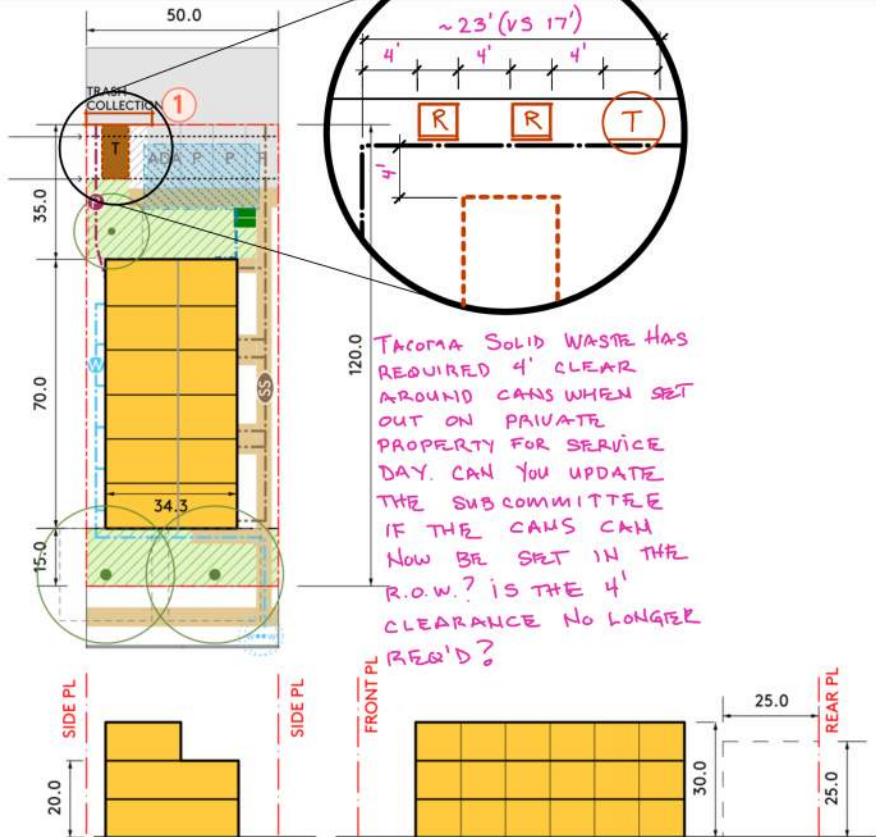

# #3A 6-unit Houseplex (Deep Townhouses)

## Building Data

- UR-1 with bonus, 6000 sf lot
- FAR: 1.0, 6,000 GSF, 2.5 stories
- Unit size: 1,000 SF

## Access & Parking

- Alley-loaded
- 4 surface parking stalls (including one accessible stall)
- 2 in-unit bike parking; 2 spaces in bike lockers

## Amenity Space

- Ground level amenity space: 1,570 SF
- Amenity space min.: 1,800

## Tree Credits

- Tree credit shown: 2,200
- Tree credit min.: 2,100
- Can meet soil volume without SPS
- Greatest soil depth to meet volume requirements: 2.6'

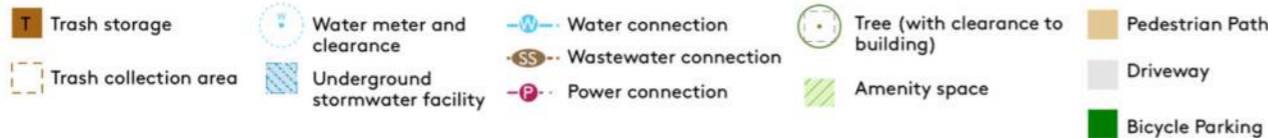
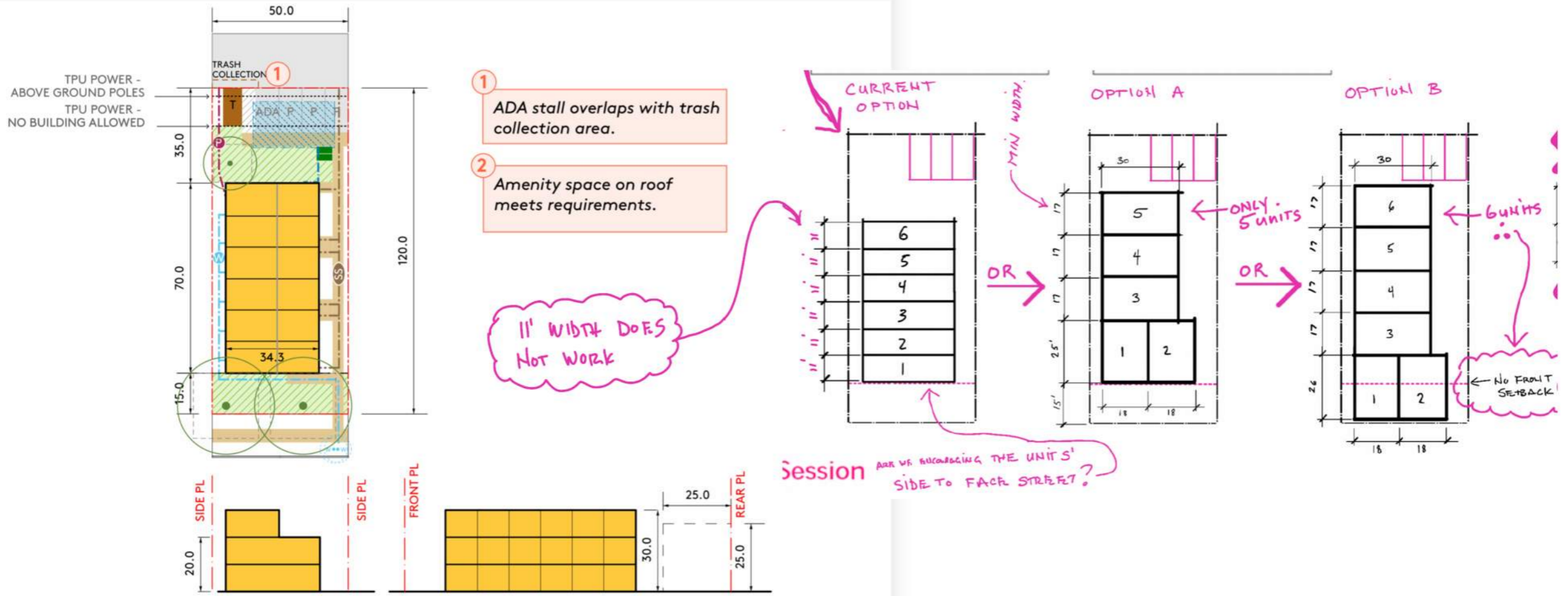

# #3A 6-unit Houseplex (Deep Townhouses)

## Building Data

- UR-1 with bonus, 6000 sf lot
- FAR: 1.0, 6,000 GSF, 2.5 stories
- Unit size: 1,000 SF

## Access & Parking

- Alley-loaded
- 4 surface parking stalls (including one accessible stall)
- 2 in-unit bike parking; 2 spaces in bike lockers

## Amenity Space

- Ground level amenity space: 1,570 SF
- Amenity space min: 1,800

## Tree Credits

- Tree credit shown: 2,200
- Tree credit min.: 2,100
- Can meet soil volume without SPS
- Greatest soil depth to meet volume requirements: 2.6'

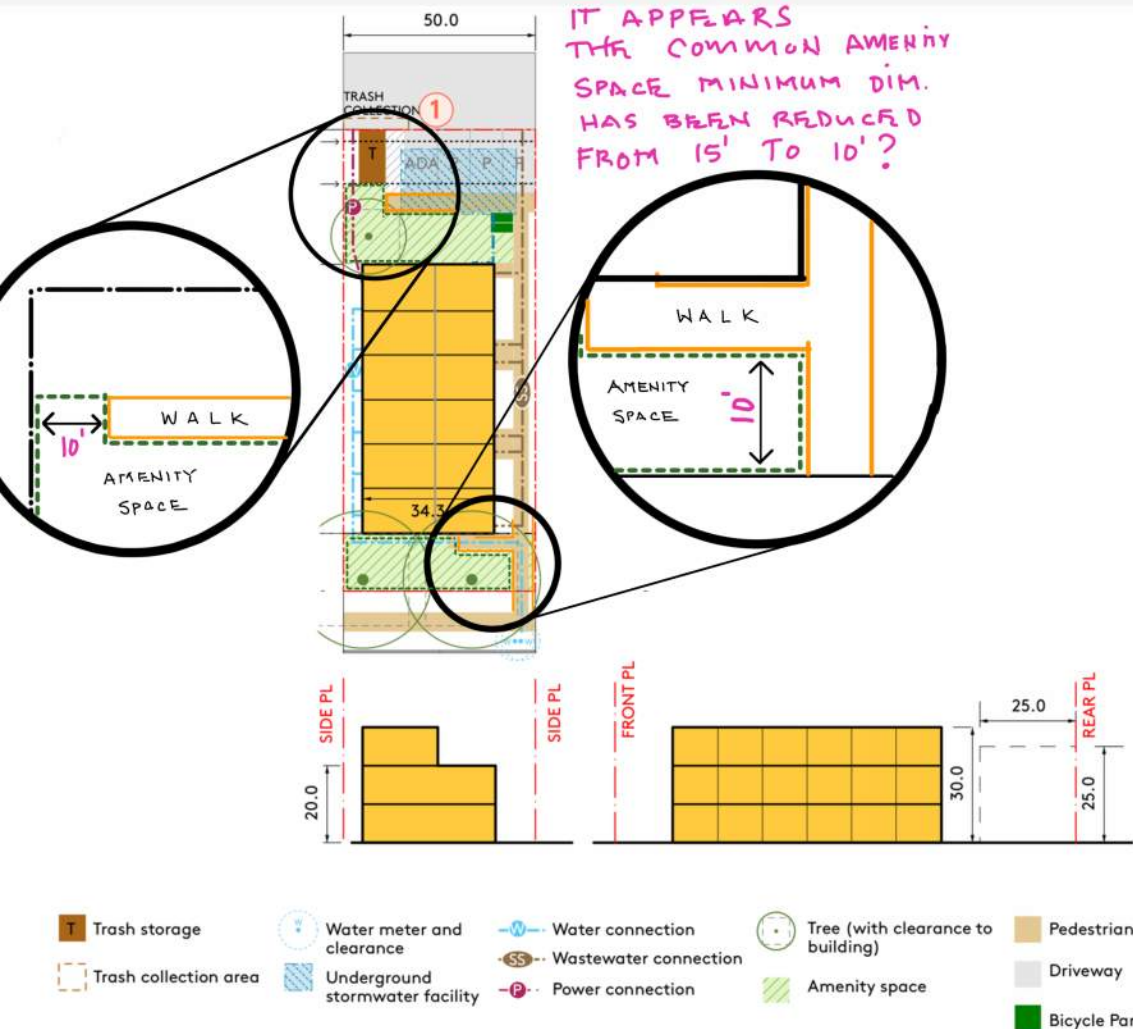

# #3A 6-unit Houseplex (Deep Townhouses)

## Building Data

- UR-1 with bonus, 6000 sf lot
- FAR: 1.0, 6,000 GSF, 2.5 stories
- Unit size: 1,000 SF

## Access & Parking

- Alley-loaded
- 4 surface parking stalls (including one accessible stall)
- 2 in-unit bike parking; 2 spaces in bike lockers

## Amenity Space

- Ground level amenity space: 1,570 SF
- Amenity space min: 1,800

## Tree Credits

- Tree credit shown: 2,200
- Tree credit min.: 2,100
- Can meet soil volume without SPS
- Greatest soil depth to meet volume requirements: 2.6'

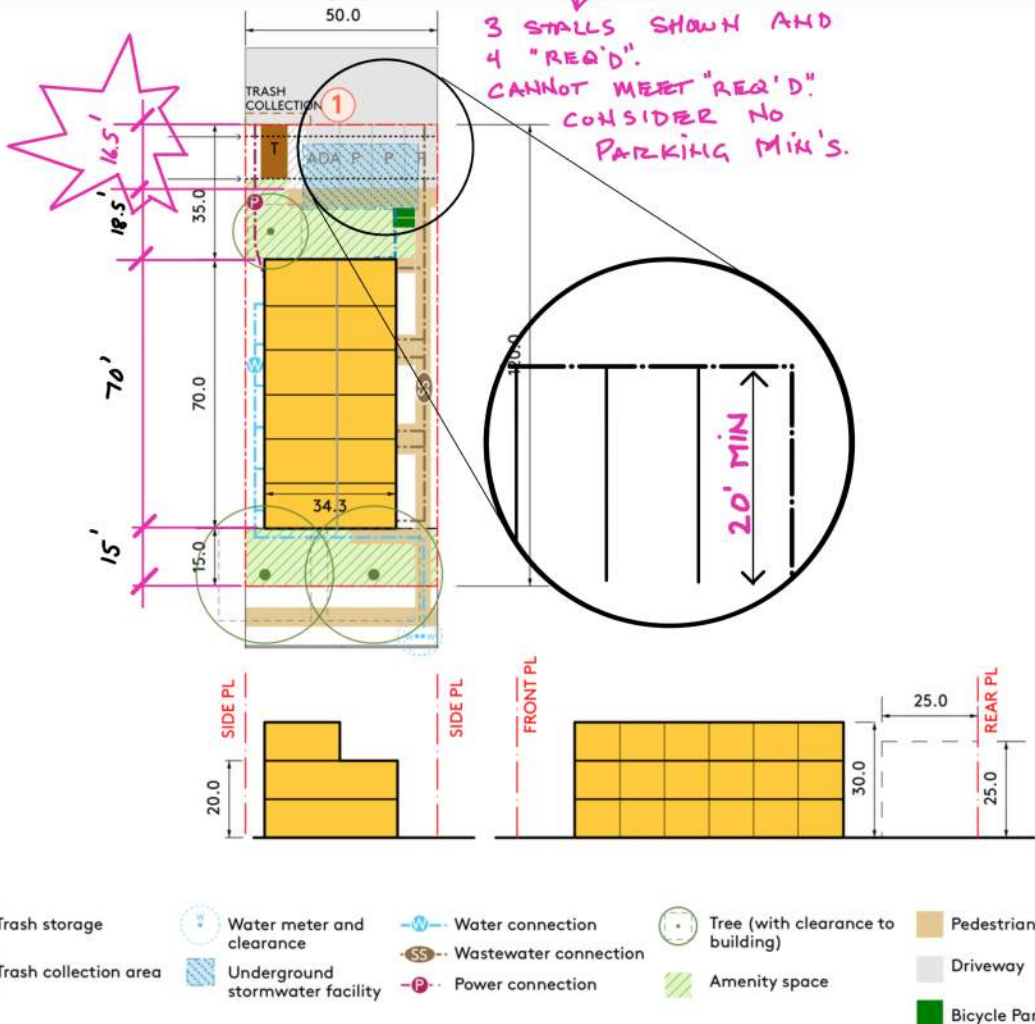

# #3B 6-unit Houseplex (Deep Townhouses)

## Building Data

- UR-1 with bonus, 6000 sf lot
- FAR: 1.0, 6,000 GSF, 2.75 stories
- Unit size: 1,000 SF

## Access & Parking

- Street-loaded
- 3 surface parking stalls (including one accessible stall)
- In-unit bike parking

## Amenity Space

- Ground level amenity space: 790 SF
- Amenity space min: 1,800

## Tree Credits

- Tree credit shown: 2,200
- Tree credit min.: 2,100
- Can meet soil volume without SPS  
Greatest soil depth to meet volume requirements: 3.6'

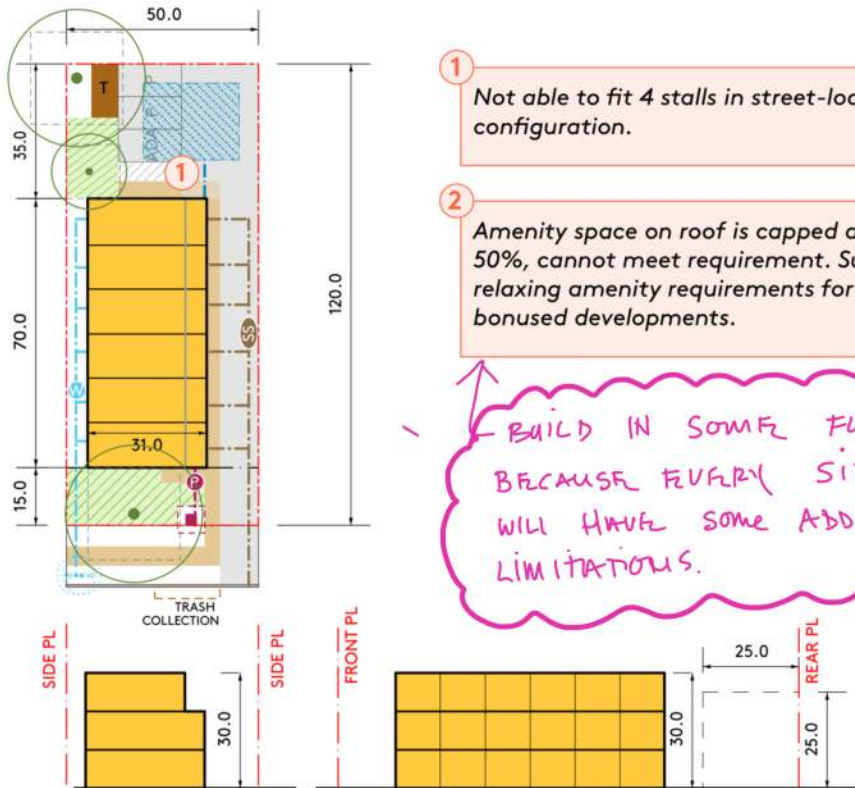

1 Not able to fit 4 stalls in street-loaded configuration.

2 Amenity space on roof is capped at 50%, cannot meet requirement. Suggest relaxing amenity requirements for bonused developments.

BUILD IN SOME FLEXIBILITY BECAUSE EVERY SITE WILL HAVE SOME ADDITIONAL LIMITATIONS.

- T Trash storage
- Water meter and clearance
- Water connection
- Wastewater connection
- Power connection
- Transformer pad
- Trash collection area
- Underground stormwater facility
- Tree (with clearance to building)
- Amenity space
- Pedestrian Path
- Driveway

# #3B 6-unit Houseplex (Deep Townhouses)

## Building Data

- UR-1 with bonus, 6000 sf lot
- FAR: 1.0, 6,000 GSF, 2.75 stories
- Unit size: 1,000 SF

## Access & Parking

- Street-loaded
- 3 surface parking stalls (including one accessible stall)
- In-unit bike parking

## Amenity Space

- Ground level amenity space: 790 SF
- Amenity space min: 1,800

## Tree Credits

- Tree credit shown: 2,200
- Tree credit min.: 2,100
- Can meet soil volume without SPS
- Greatest soil depth to meet volume requirements: 3.6'

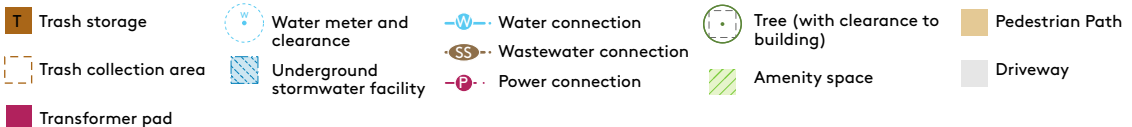
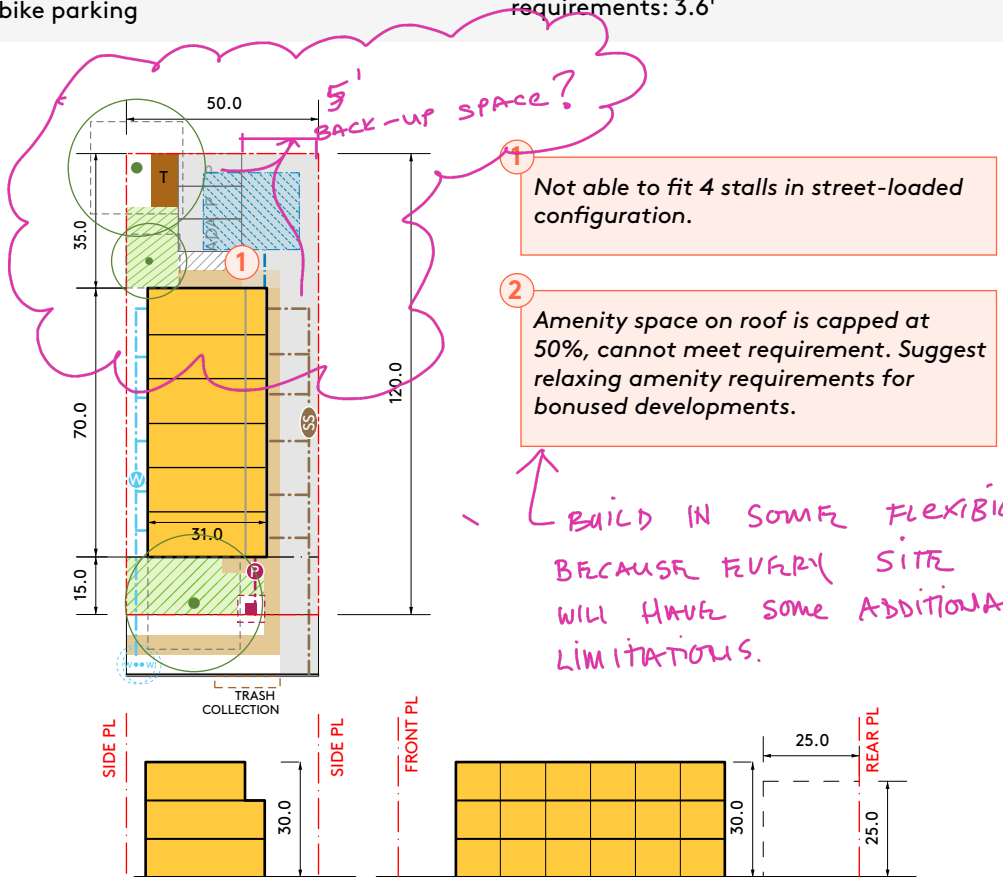

# #6 Multiplex with 24 Units

## Building Data

- UR-3 with bonus, 12,000 sf lot
- FAR: 1.6, 19,200 GSF, 4 stories
- Unit size: 680 SF  
(Excluding 650 SF per level for access and ground-floor bike room)

## Access & Parking

- Street-loaded
- 12 surface parking stalls (including one accessible stall)
- Bike room: 260 SF, 18 spaces

## Amenity Space

- Ground level amenity space: 1,200 SF
- Amenity space min.: 2,400

## Tree Credits

- Tree credit shown: 3,200
- Tree credit min.: 3,000
- Can meet soil volume without SPS  
Greatest soil depth to meet volume requirements: 2.1'

4 STORIES W/O ELEVATOR?

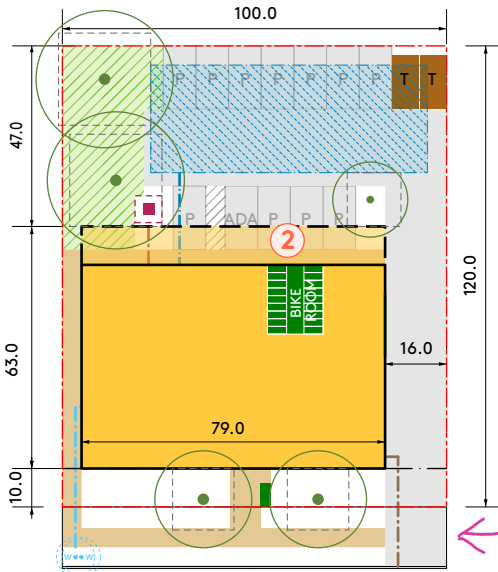

1 Amenity space on roof meets requirements. However, roof decks of that size require an expensive elevator and 2 egress stairs.

2 This study shows tuck-under parking to meet unit and FAR goals. This is only necessary in street-loaded conditions, and would not be necessary in reduced parking areas (because of reduced parking requirements).

← CONSIDER TO PARKING MINIMUM IN THIS CASE.

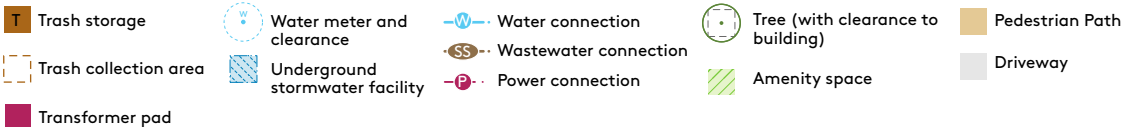
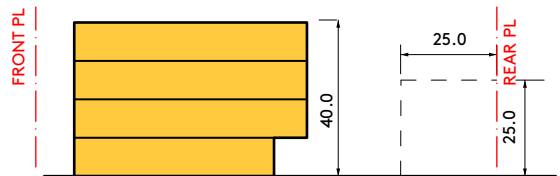
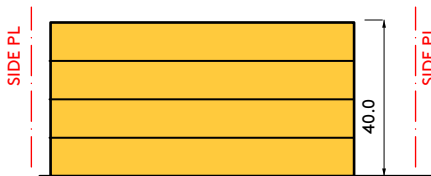

## Exhibit B – Backyard building map overlays

This exhibit shows the backyard building potential of several additional neighborhoods around Tacoma, selected at random. As noted by Mithūn, backyard buildings generally won't fit if the existing house extends beyond around 48.5 ft from the front property line. In this exhibit, we have superimposed lines at approximately 48.5 ft from the front property line. The vast majority of existing homes extend beyond this line, making them ineligible for backyard buildings.

Note that many of the lots in the following images are smaller than a standard lot that Mithūn used in creating these site plans (6,000 sq ft, measuring 50 ft x 120 ft). Therefore, the proposed regulations may prohibit even more backyard development than it appears from the following images.









47.9'

48.0'



47.9'

47.9'

**From:** Lawrencium <larryleveen@gmail.com>  
**Sent:** Tuesday, September 24, 2024 8:43 PM  
**To:** City Clerk's Office  
**Subject:** Home in Tacoma 2 Testimony

[Please forward to the Tacoma City Council. Thank you.]

Dear Tacoma City Council,

I am writing regarding Home in Tacoma 2. I was unable to stay to deliver my comments in person due to a conflict with a PSRC meeting about Vision Zero at the Tacoma Art Museum. However, a helpful staffer in the Council chambers said I could email my testimony to you.

Land use locks in mobility patterns. A legacy of low-density single-land use zoning has led to sprawl throughout much of our city and county, which fosters car dependency, leads to overly expensive infrastructure just to store moving and parked cars, and makes it more difficult for Pierce Transit to provide cost-effective fixed route service. In the end, this leads to higher tax rates just to plug all these externalized costs.

When folks get priced out of local housing markets and are displaced into the unincorporated areas of Pierce County. However, their respective commute trips remain. Sprawling, low-density land use decisions of the past are increasingly significant contributors to greenhouse gas emissions. Housing affordability is a key part of addressing climate change.

I know change is scary. I am lucky enough to have a lovely view of Mount Rainier from the living room of my house just a block away from S. 56<sup>th</sup> & Pacific Avenue. I know that view could potentially go away if taller multiuse structures were built along that corridor. As I thought about that possibility and other potential scary changes, I realized my inner conflict was essentially a case of “Chicken Little vs. Missing Middle”. So, I sat with that and reflected on my situation — and my privilege as a homeowner.

Since I bought my house five years ago, its value has risen greatly — roughly 25%! Zillow wants me to be happy about that, but frankly, it nauseates me because housing-as-speculative-investment (particularly when powered by venture capital) is inhumane to others and economically and environmentally unsustainable. It is unconscionable for those who “have” to lock out the “have nots” by opposing the densification of our community to increase housing. If my Mount Rainier view is blocked by a taller development resulting from HIT, I would miss it, but frankly, I would get over it. Chicken Little is wrong — the sky will not fall. But, if Tacoma’s policy is thoughtfully crafted, others might just get a shot at housing stability and potentially home ownership.

Many people are telling you that transit and other modes can’t work or can’t work here. That is patently wrong. Naysayers incorrectly apply today’s service and travel distances to this equation when, instead, they should imagine a scenario with more, closer destinations and transit service with higher frequencies that reduce the need for car travel. I fear they are “resting in their privilege” because the current system works for them. Except they are ignoring climate, congestion, air and water pollution, and the epidemic of violence on our roadways resulting from car-centric planning

(40,000 Americans killed annually). The current system isn't working for them either, but they aren't looking at a big enough picture to realize it. We need a more equitable system that works for everyone.

To address our mobility patterns, ills, and issues, you must address the underlying land use zoning that locks in those patterns. I urge you to make the brave choice to continue supporting Home in Tacoma 2, along with the expanded Reduced Parking Area. Thank you.

---

Larry Leveen

360.357.3871

<http://linkedin.com/in/larryleveen>

<https://calendly.com/larryleveen>

**From:** Elizabeth Keathley <elkeathl@uncg.edu>  
**Sent:** Wednesday, September 25, 2024 8:14 AM  
**To:** City Clerk's Office  
**Subject:** Comment on Home in Tacoma

Hello, I attended the City Council meeting last night and signed up to speak about Home in Tacoma, but was not able to speak, and I was told I could send an e-mail, and this is it.

I am very much in favor of higher density, affordable, sustainable infill development in Tacoma, but we must really be certain it's sustainable and doesn't reproduce the environmental injustice that is already rife in our fair city.

I understand that there is a move to remove or weaken the requirements for tree canopy and green space, and any such proposal must be rejected. The climate crisis is an existential threat, and no other concern should eclipse that.

We also have an obligation to provide a healthy environment for all of our neighbors in Tacoma and should use this opportunity to help rectify the unequal distribution of health-giving trees and green space and the infrastructural benefits trees provide, like flood mitigation.

The city council should also do something about real estate brokers hoarding housing stock. That is really immoral with so many unhoused citizens in our town.

Kamala Harris is proposing development of affordable housing, and if Home in Tacoma can keep higher density developments affordable and sustainable, we could offer a national model.

With kind thanks for reading,

Elizabeth L Keathley, PhD [elkeathl@uncg.edu](mailto:elkeathl@uncg.edu)  
1230 N. Fife St.  
Tacoma, WA 98406

Professor Emerita of Music History and Women's, Gender, and Sexuality Studies  
Faculty Fellow, Lloyd International Honors College  
School of Music  
University of North Carolina, Greensboro

Associate Editor, Journal of the International Alliance for Women in Music

"We are in the beginning of a mass extinction, and all you can talk about is money and fairy tales of eternal economic growth. How dare you!"

—Greta Thunberg (b. 2003) at UN Climate Action Summit, 23 September 2019

Check out our Black Opera Symposium!

<https://vpa.uncg.edu/single-event/black-identities-on-the-operatic-stage-a-symposium-with-music/>

Read our edition of Schoenberg's Correspondence with Alma Mahler!

<https://global.oup.com/academic/product/schoenbergs-correspondence-with-alma-mahler-9780195381962#.YNYe0CtnbQk.gmail>

**From:** Michael Ferneding <cactushawk@mac.com>  
**Sent:** Wednesday, September 25, 2024 8:29 AM  
**To:** City Clerk's Office; Home In Tacoma  
**Subject:** Home in Tacoma

Alyssa,

It was so nice to talk to you today about Home in Tacoma zoning. I looked at the on line talk this past weekend and also the material on the web page. I am the owner of the large piece of property (total on acre) at 3566 E Crandall Ln. between Pacific Ave and A Street. I am requesting the this street also be included in the ULS area. In my opinion it is close in the city with the utilities available and could have a benefit to the community if it had the current zoning and also the newer higher density. If you could please look into this request before the final vote. I really appreciate what you are doing and what a great thing for the City of Tacoma.

Regards,

Michael T. Ferneding  
253-226-0452



**From:** Home In Tacoma  
**Sent:** Wednesday, September 25, 2024 10:47 AM  
**To:** City Clerk's Office  
**Subject:** FW: Historic home districts

Please see comment for the Home In Tacoma public hearing.

Alyssa

-----Original Message-----

From: Paige Carness <paigecarness@gmail.com>  
Sent: Wednesday, September 25, 2024 9:35 AM  
To: Home In Tacoma <HomeInTacoma@cityoftacoma.org>  
Subject: Historic home districts

Dear Home In Tacoma,  
I live in an area that would be rezoned.

I recently moved to Tacoma and paid 1.2 million dollars for my 1899 Queen Anne home. I am walking distance to the iconic Stadium Highschool. We love what everyone loves about Tacoma its character and charm.

There is no doubt that we are in the city, I have people urinating on my street trees and sleeping on the corner of street. That is 5th and North E st. The kids and I care for the yard we pickup the trash people throw in our yard and we plant flowers. The kids ask, why? No one cares. I tell them that because we are here we show people that we care by keeping it nice and that allows everyone to walk down this street and feel relaxed. It's like smiling when you walk past someone, you don't have to, but it is a small act of kindness.

On my street there are several apartments. Large homes that have been turned into apartments. The church owns a house where they offer temporary housing. The house across from me at one time had a huge dome and two fireplaces. It has been reduced to the most basic of architecture. Another house has apartments for traveling nurses. Some houses turned apartments look great, while others look dilapidated with the structure falling apart and trees dying.

My neighborhood already feels dense. There are many apartment buildings with for rent signs up, especially on Yakima.

Rather than putting more apartment buildings into the neighborhood, can we revitalize the buildings down town and turn them into apartments? It seems like there are many vacant building down town.

I don't want to see my beautiful neighborhood filled with historic homes turned into a mix match of apartment buildings and cheap modern duplexes.

Our neighborhood looks the way it does because the people who live here take care of it. We maintain the street trees and pay to have them trimmed. We keep the historic integrity of the houses. We make it a walkable neighborhood because we walk it. We live here. We are invested in it. Our children use these parks and go to these schools.

Developers and landlords do not have the same personal connection, only their wallets are invested here. As residents, we have invested our time, our money, our hearts.

Please don't destroy what beauty remains.

Consider making historic zones. Such that residents can vote to change the zone to a historic one preventing demolition of historic houses and building of multiplex.

Thank you,

Paige

**From:** Home In Tacoma  
**Sent:** Wednesday, September 25, 2024 10:48 AM  
**To:** City Clerk's Office  
**Subject:** FW: Home In Tacoma Inquiry and request for UR3  
**Attachments:** Waterview PDF 3 topi.pdf; SITE Plan.pdf

Please see comment for Home In Tacoma.

Alyssa

---

**From:** dave baumgardner <d1baum@yahoo.com>  
**Sent:** Wednesday, September 25, 2024 10:15 AM  
**To:** Home In Tacoma <HomeInTacoma@cityoftacoma.org>  
**Cc:** Hines, John <JHines1@cityoftacoma.org>; Boudet, Brian <BBoudet@cityoftacoma.org>; Schultz, Shirley <SSchultz@cityoftacoma.org>  
**Subject:** Home In Tacoma Inquiry and request for UR3

Dear Council and Staff,

I am writing to request my property be included in the UR3 designation for Home in Tacoma.

My property is approximately 9 acres adjacent to Point Ruston.

There are many reasons this property fits better in the UR3 zone.

1. It's a 3-5 minute walk to "Centers and Corridors" and transportation being adjacent to Pt Ruston as required in UR3.
2. The property is unique in that the topo on south side is a slope of 100' high, meaning it will not block any views in VSD to neighboring homes.
3. The property is closer in access and proximity to Pt Ruston given there is only one street which connects this 9 acres to the balance of the community and neighborhoods to the south. (Waterview).
4. Previous zoning and careful planning accommodated approximately 100 town homes or 250 apartments. The existing UR1 would not even meet those numbers, so result in an actual decrease in units.
5. The property is currently 90% vacant (few existing homes which eventually may need to be demolished). So the land is mostly "a blank slate" which lends itself to creative and thoughtful planning and design.

UR3 will allow for the most thoughtful and carefully planned housing to maximize this site.

Here is an exhibit including boundary lines and topo. The second is layout under current zoning.

Please confirm receipt of this email and if any other data or information is needed.

Thank you

David Baumgardner  
(253) 961-6915

A PORTION OF  
THE S.E. 1/4 OF THE N.E. 1/4 OF SECTION 23 AND TOWNSHIP 21 NORTH, RANGE 2 EAST, W.M.  
TOWN OF RUSTON, PIERCE COUNTY, WASHINGTON  
AND  
THE S.W. 1/4 OF THE N.W. 1/4 OF SECTION 24, TOWNSHIP 21 NORTH, RANGE 2 EAST, W.M.  
CITY OF TACOMA, PIERCE COUNTY, WASHINGTON

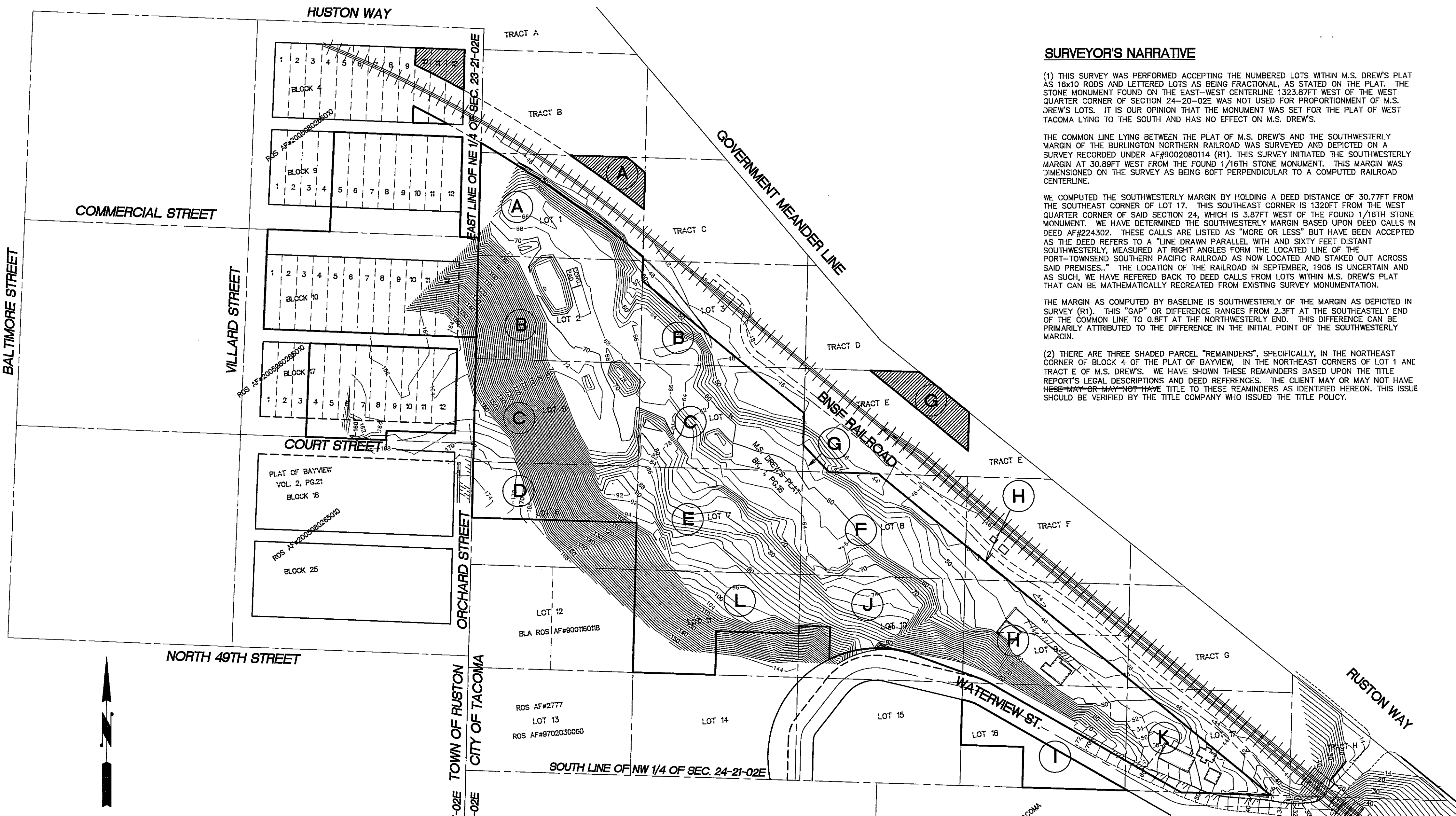

- LEGAL DESCRIPTIONS**  
*(PER COMMONWEALTH LAND TITLE CO. ORDER NO. RM-20184052, DATED SEP. 28, 2005)*
- LOTS 10 TO 12, INCLUSIVE, BLOCK 4, LESS NORTHERN PACIFIC RAILWAY OPERATIONS PROPERTY; LOTS 5 TO 12, INCLUSIVE, BLOCK 9, INCLUDING 40.0 FEET OF COMMERCIAL STREET VACATED, LESS NORTHERN PACIFIC OPERATION PROPERTY;  
LOTS 1 TO 12, INCLUSIVE, BLOCK 10, INCLUDING 40.0 FEET OF COMMERCIAL STREET VACATED AND 1ST STREET VACATED;  
LOTS 4 TO 12, INCLUSIVE, BLOCK 17, ALL IN BAY VIEW, ACCORDING TO THE PLAT THEREOF RECORDED IN VOLUME 2 OF PLATS AT PAGE 21, RECORDS OF PIERCE COUNTY AUDITOR;  
SITUADE IN THE CITY OF RUSTON, COUNTY OF PIERCE, STATE OF WASHINGTON.
- (PER FIRST AMERICAN TITLE INSURANCE CO. POLICY NO. 4262-558565 DATED MAY 02, 2005)*
- PARCEL A:**  
LOT 1 OF M.S. DREWS' PLAT, ACCORDING TO PLAT RECORDED IN BOOK 1 OF PLATS AT PAGE(S) 16, IN TACOMA, PIERCE COUNTY, WASHINGTON.  
EXCEPT THAT PORTION CONVEYED TO NORTHERN PACIFIC RAILWAY COMPANY BY DEED RECORDED OCTOBER 1, 1912 UNDER AUDITOR'S NO. 368323;  
ALSO EXCEPT THAT PORTION CONVEYED TO AMERICAN SMELTING AND REFINING COMPANY, A NEW JERSEY CORPORATION, BY DEED RECORDED JANUARY 23, 1923 UNDER AUDITOR'S NO. 655370.
- PARCEL B:**  
LOT 2, TOGETHER WITH THAT TRIANGULAR PORTION IN THE SOUTHWEST CORNER OF LOT 3, LYING SOUTHWESTERLY OF NORTHERN PACIFIC RAILROAD RIGHT OF WAY OF M.S. DREWS' PLAT, ACCORDING TO PLAT RECORDED IN BOOK 1 OF PLATS AT PAGE(S) 16, IN TACOMA, PIERCE COUNTY, WASHINGTON.
- PARCEL C:**  
LOT 4 AND ALL OF LOT 5 OF M.S. DREWS' PLAT, ACCORDING TO PLAT RECORDED IN BOOK 1 OF PLATS AT PAGE(S) 16, IN TACOMA, PIERCE COUNTY, WASHINGTON.  
EXCEPT THAT PORTION CONVEYED TO NORTHERN PACIFIC RAILWAY COMPANY.
- PARCEL D:**  
THE NORTH 90 FEET OF LOT 6 OF M.S. DREWS' PLAT, ACCORDING TO PLAT RECORDED IN BOOK 1 OF PLATS AT PAGE(S) 16, IN TACOMA, PIERCE COUNTY, WASHINGTON.
- PARCEL E:**  
LOT 7 OF M.S. DREWS' PLAT, ACCORDING TO PLAT RECORDED IN BOOK 1 OF PLATS AT PAGE(S) 16, IN TACOMA, PIERCE COUNTY, WASHINGTON.
- PARCEL F:**  
LOT 8 OF M.S. DREWS' PLAT, ACCORDING TO PLAT RECORDED IN BOOK 1 OF PLATS AT PAGE(S) 16, IN TACOMA, PIERCE COUNTY, WASHINGTON.  
EXCEPT THAT PORTION CONVEYED TO NORTHERN PACIFIC RAILWAY COMPANY.
- PARCEL G:**  
THOSE PORTIONS OF TRACT E OF M.S. DREWS' PLAT, ACCORDING TO PLAT RECORDED IN BOOK 1 OF PLATS AT PAGE(S) 16, LYING NORTHEASTERLY OF THE RIGHT OF WAY OF THE NORTHERN PACIFIC RAILWAY COMPANY AND SOUTHWESTERLY OF THE TRACT OF LAND CONVEYED TO PORT TOWNSEND SOUTHERN RAILROAD COMPANY BY DEED RECORDED UNDER AUDITOR'S NO. 218183, IN TACOMA, PIERCE COUNTY, WASHINGTON.
- PARCEL H:**  
THOSE PORTIONS OF TRACTS F, G AND LOT 9 OF M.S. DREWS' PLAT, ACCORDING TO PLAT RECORDED IN BOOK 1 OF PLATS AT PAGE(S) 16, LYING SOUTHWESTERLY OF THOSE TRACTS OF LAND CONVEYED TO PORT TOWNSEND SOUTHERN RAILROAD COMPANY BY DEEDS RECORDED UNDER AUDITOR'S NOS. 2242302, 228501, AND 228502, IN TACOMA, PIERCE COUNTY, WASHINGTON.
- PARCEL I:**  
TRACT 16 OF M.S. DREWS' PLAT, ACCORDING TO PLAT RECORDED IN BOOK 1 OF PLATS AT PAGE(S) 16, IN TACOMA, PIERCE COUNTY, WASHINGTON.  
EXCEPT THE SOUTH 65 FEET OF THE WEST 100 FEET THEREOF;  
ALSO EXCEPT WATERVIEW STREET.
- PARCEL J:**  
TRACT 10 OF M.S. DREWS' PLAT, ACCORDING TO PLAT RECORDED IN BOOK 1 OF PLATS AT PAGE(S) 16, IN TACOMA, PIERCE COUNTY, WASHINGTON.  
EXCEPT THE WEST 50 FEET OF THE SOUTH HALF THEREOF;  
ALSO EXCEPT WATERVIEW STREET.
- PARCEL K:**  
LOT 17 OF M.S. DREWS' PLAT, ACCORDING TO PLAT RECORDED IN BOOK 1 OF PLATS AT PAGE(S) 16, IN TACOMA, PIERCE COUNTY, WASHINGTON.  
EXCEPT THAT PORTION THEREOF LYING NORTHEASTERLY OF THE SOUTHWESTERLY LINE OF THAT TRACT CONVEYED TO THE PORT TOWNSEND SOUTHERN RAILROAD COMPANY BY DEED DATED SEPTEMBER 25, 1906 AND RECORDED OCTOBER 13, 1906 IN BOOK 294 OF DEEDS AT PAGE 433, WHICH TRACT WAS DESCRIBED AS LYING NORTHEASTERLY OF A LINE DRAWN PARALLEL WITH AND 60 FEET DISTANT SOUTHWESTERLY MEASURED AT RIGHT ANGLE FROM THE LOCATED LINE OF PORT TOWNSEND SOUTHERN RAILROAD AS LOCATED AND STAKED OUT ACROSS SAID PREMISES, BEING ALL THAT PART OF SAID LOT LYING NORTHEASTERLY OF A STRAIGHT LINE DRAWN FROM A POINT ON THE SOUTH LINE OF SAID LOT 17, 30.77 FEET, MORE OR LESS, WEST FROM THE SOUTHEAST CORNER OF SAID LOT, NORTHWESTERLY TO A POINT ON THE DIVIDING LINE BETWEEN THE NORTH HALF AND THE SOUTH HALF OF LOT 9 IN SAID M.S. DREWS' PLAT, 177.09 FEET, MORE OR LESS, EASTERLY FROM THE NORTHWEST CORNER OF THE SOUTH HALF OF SAID LOT 9;  
ALSO EXCEPT THAT PART TAKEN AND CONDEMNED BY THE CITY OF TACOMA FOR ROADWAY IN CONDEMNATION PROCEEDINGS UNDER PIERCE COUNTY SUPERIOR COURT CAUSE NO. 27163.
- PARCEL L:**  
LOT 11 OF M.S. DREWS' PLAT, ACCORDING TO PLAT RECORDED IN BOOK 1 OF PLATS AT PAGE(S) 16, IN TACOMA, PIERCE COUNTY, WASHINGTON.  
EXCEPT THE SOUTH 70 FEET OF THE EAST HALF THEREOF.

**SURVEYOR'S NARRATIVE**

(1) THIS SURVEY WAS PERFORMED ACCEPTING THE NUMBERED LOTS WITHIN M.S. DREWS' PLAT AS 16X10 RODS AND LETTTERED LOTS AS BEING FRACTIONAL, AS STATED ON THE PLAT. THE STONE MONUMENT FOUND ON THE EAST-WEST CENTERLINE 1323.87FT WEST OF THE WEST QUARTER CORNER OF SECTION 24-20-02E WAS NOT USED FOR PROPORTIONMENT OF M.S. DREWS' LOTS. IT IS OUR OPINION THAT THE MONUMENT WAS SET FOR THE PLAT OF WEST TACOMA LYING TO THE SOUTH AND HAS NO EFFECT ON M.S. DREWS'.  
THE COMMON LINE LYING BETWEEN THE PLAT OF M.S. DREWS' AND THE SOUTHWESTERLY MARGIN OF THE BURLINGTON NORTHERN RAILROAD WAS SURVEYED AND DEPICTED ON A SURVEY RECORDED UNDER AF#9002080114 (R1). THIS SURVEY INITIATED THE SOUTHWESTERLY MARGIN AT 30.89FT WEST FROM THE FOUND 1/16TH STONE MONUMENT. THIS MARGIN WAS DIMENSIONED ON THE SURVEY AS BEING 60FT PERPENDICULAR TO A COMPUTED RAILROAD CENTERLINE.  
WE COMPUTED THE SOUTHWESTERLY MARGIN BY HOLDING A DEED DISTANCE OF 30.77FT FROM THE SOUTHEAST CORNER OF LOT 17. THIS SOUTHEAST CORNER IS 1320FT FROM THE WEST QUARTER CORNER OF SAID SECTION 24, WHICH IS 3.87FT WEST OF THE FOUND 1/16TH STONE MONUMENT. WE HAVE DETERMINED THE SOUTHWESTERLY MARGIN BASED UPON DEED CALLS IN DEED AF#224302. THESE CALLS ARE LISTED AS "MORE OR LESS" BUT HAVE BEEN ACCEPTED AS THE DEED REFERS TO A "LINE DRAWN PARALLEL WITH AND SIXTY FEET DISTANT SOUTHWESTERLY, MEASURED AT RIGHT ANGLES FROM THE LOCATED LINE OF THE PORT-TOWNSEND SOUTHERN PACIFIC RAILROAD AS NOW LOCATED AND STAKED OUT ACROSS SAID PREMISES." THE LOCATION OF THE RAILROAD IN SEPTEMBER, 1906 IS UNCERTAIN AND AS SUCH, WE HAVE REFERRED BACK TO DEED CALLS FROM LOTS WITHIN M.S. DREWS' PLAT THAT CAN BE MATHEMATICALLY RECREATED FROM EXISTING SURVEY MONUMENTATION.  
THE MARGIN AS COMPUTED BY BASELINE IS SOUTHWESTERLY OF THE MARGIN AS DEPICTED IN SURVEY (R1). THIS "GAP" OR DIFFERENCE RANGES FROM 2.3FT AT THE SOUTHEAST END OF THE COMMON LINE TO 0.8FT AT THE NORTHWESTERLY END. THIS DIFFERENCE CAN BE PRIMARILY ATTRIBUTED TO THE DIFFERENCE IN THE INITIAL POINT OF THE SOUTHWESTERLY MARGIN.

(2) THERE ARE THREE SHADED PARCEL "REMAINDERS", SPECIFICALLY, IN THE NORTHEAST CORNER OF BLOCK 4 OF THE PLAT OF BAYVIEW, IN THE NORTHEAST CORNERS OF LOT 1 AND TRACT E OF M.S. DREWS'. WE HAVE SHOWN THESE REMAINDERS BASED UPON THE TITLE REPORT'S LEGAL DESCRIPTIONS AND DEED REFERENCES. THE CLIENT MAY OR MAY NOT HAVE THESE OR MAY NOT HAVE TITLE TO THESE REMAINDERS AS IDENTIFIED HEREON. THIS ISSUE SHOULD BE VERIFIED BY THE TITLE COMPANY WHO ISSUED THE TITLE POLICY.

**SURVEYOR'S NOTES**

(1) THE DRAWING SHOWN HEREON DOES NOT NECESSARILY CONTAIN ALL OF THE INFORMATION OBTAINED BY THE SURVEYOR IN HIS FIELD WORK, OFFICE WORK, OR RESEARCH.

(2) BASELINE'S FIELD TRAVERSE PROCEDURES MEET OR EXCEED ACCURACY STANDARDS AS PER W.A.C. 332-130-090, PARAGRAPHS 1(a) AND 1(b).

(3) APPARENT ENCROACHMENTS AS SHOWN HEREON ARE ONLY THOSE ABOVE GROUND, VISIBLE OBJECTS OBSERVED BY THE SURVEYOR. NO CERTIFICATION IS MADE OR IMPLIED THAT THOSE OBJECTS APPEARING TO ENCROACH ACTUALLY ENCROACH ON THE OWNERSHIP OF THE SUBJECT OR ADJOINING PROPERTY.

(4) UTILITIES, OTHER THAN THOSE SHOWN, MAY EXIST ON OR ADJACENT TO THE SITE. ONLY THOSE WHICH ARE VISIBLE, OR WHERE THERE IS VISIBLE EVIDENCE OF THEIR LOCATION HAVE BEEN LOCATED BY SURVEY. THE ACCURACY AND COMPLETENESS OF DATA OBTAINED BY OTHER THAN FIELD SURVEY METHODS IS NOT GUARANTEED. PRIOR TO ANY PHASE OF CONSTRUCTION, THE CONTRACTOR SHALL VERIFY WITH THE APPROPRIATE UTILITY AGENCY OWNER, THE EXACT LOCATION, SIZES AND MATERIALS OF ALL UTILITIES WHICH MAY BE AFFECTED.

(5) AN ON THE GROUND SURVEY WAS PERFORMED DEC. 2005 & JAN. 2006.

(6) THIS SURVEY DOES NOT PURPORT TO SHOW ALL EASEMENTS OF RECORD, IF ANY.

(7) PURPOSE OF THE SURVEY WAS TO LOCATE THE TOP AND TOE OF THE EXISTING 75FT HIGH SLOPE ABUTTING THE BURLINGTON NORTHERN SANTE FE RAILROAD MARGIN, AS WELL LOCATE SIGNIFICANT FEATURES FOR MAPPING PURPOSES. ENCROACHMENTS ALONG INDIVIDUAL BOUNDARY LINES WERE NOT INVESTIGATED AS PART OF THIS SURVEY.

(8) DEED AF#909544 ALLOWS THE CITY OF TACOMA TO MAKE THE NECESSARY SLOPES FOR CUTS AND FILLS ACROSS PORTIONS OF LOT 9 AND 10 OF M.S. DREWS'. THE DOCUMENT IS NOT SPECIFIC ABOUT THE LOCATION OF THE RIGHTS TO MAKE THESE GRADE CHANGES.

**SURVEYOR'S REFERENCES**

(R1) RECORD OF SURVEY BY ROBERT BOYD DATED 1-08-90, AF#9002080114  
(R2) RECORD OF SURVEY BY DANIEL ACKERMAN DATED 8-25-05, AF#200508285010  
(R3) RECORD OF SURVEY BY BLAIR FRIGGE DATED 06-06-01, AF#200109225303  
(R4) RECORD OF SURVEY BY RANDALL HAYDON DATED 02-97, AF#9702030060  
(R5) RECORD OF SURVEY BY CHARLES HAVILAND DATED 06-29-90, AF#9001160118  
(R6) RECORD OF SURVEY BY DAVE BERG DATED 07-02-79, AF#27277  
(P1) M.S. DREWS' PLAT, VOL. 1 OF PLATS, PG. 16.  
(P2) BAYVIEW ADDITION DATED JUNE 19, 1888.

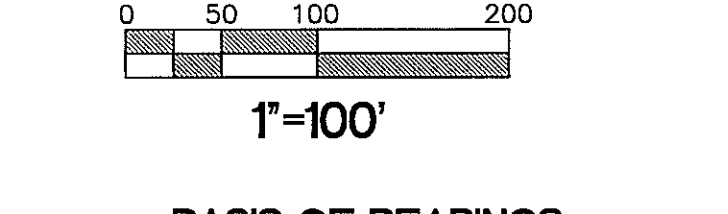

**BASIS OF BEARINGS**  
WA STATE PLANE COORDINATE SYSTEM, NAD83-91, SOUTH ZONE, AS DEFINED BY THE CITY OF TACOMA DEPT. OF PUBLIC WORKS PUBLISHED COORDINATES FOR MONUMENTS ALONG ORCHARD ST. AT NORTH 49TH STREET (EAST) AND AT NORTH 47TH STREET (EAST)  
BEARING=501°32'21"W

**VERTICAL DATUM**  
NGVD29, AS DEFINED BY THE CITY OF TACOMA DEPT. OF PUBLIC WORKS PUBLISHED ELEVATION FOR BENCHMARK #4220, BRASS DISK AT BACK OF CURBLINE OF NORTH 46TH ST. & N. VILLARD ST. INTERSECTION  
ELEVATION=243.85 FEET

**NOTE:**  
EXISTING UTILITY LOCATIONS SHOWN HEREON ARE APPROXIMATE ONLY. IT SHALL BE THE CONTRACTOR'S RESPONSIBILITY TO DETERMINE THE EXACT VERTICAL AND HORIZONTAL LOCATION OF ALL EXISTING UNDERGROUND UTILITIES PRIOR TO COMMENCING CONSTRUCTION. NO REPRESENTATION IS MADE THAT ALL EXISTING UTILITIES ARE SHOWN HEREON. THE ENGINEER ASSUMES NO RESPONSIBILITY FOR UTILITIES NOT SHOWN OR UTILITIES NOT SHOWN IN THEIR PROPER LOCATION. CALL BEFORE YOU DIG: 1-800-424-5555

**Call before you Dig**  
1-800-424-5555  
UNDERGROUND SERVICE (USA)

**SHEET INDEX**  
1. COVER SHEET  
2. WEST HALF OF SITE  
3. EAST HALF OF SITE

No.	Date	By	Appr.	Revision

DESIGNED: N/A  
DRAWN: WEL/TJN  
CHECKED: GCA  
DATE: MARCH, 2006  
SCALE: 1"=100'

**BASELINE ENGINEERING, INC.**  
*Land Development Professional Services*  
(253)565-4491 • Seattle (206)824-1205 • FAX (253)565-8563  
Land Planning & Use • Engineering • Surveying  
1910-64th Avenue West, • Tacoma, WA 98466



OWNER/DEVELOPER:

**DAVE BAUMGARDNER**  
4016 52ND AVE. CT. N.W.  
GIG HARBOR, WA 98335

TITLE:

**BOUNDARY AND TOPOGRAPHIC SURVEY  
COVER SHEET**

**BAUMGARDNER**

RUSTON AND TACOMA WASHINGTON

SHEET	1 of 3
JOB NO.	03037.1

A PORTION OF  
 THE S.E. 1/4 OF THE NE. 1/4 OF SECTION 23 AND TOWNSHIP 21 NORTH, RANGE 2 EAST, W.M.  
 TOWN OF RUSTON, PIERCE COUNTY, WASHINGTON  
 AND  
 THE S.W. 1/4 OF THE NW. 1/4 OF SECTION 24, TOWNSHIP 21 NORTH, RANGE 2 EAST, W.M.  
 CITY OF TACOMA, PIERCE COUNTY, WASHINGTON

**LEGAL DESCRIPTION**

(PER COMMONWEALTH LAND TITLE CO. ORDER NO. RM-20104052, DATED SEP. 28, 2005)  
 LOTS 10 TO 12, INCLUSIVE, BLOCK 4, LESS NORTHERN PACIFIC RAILWAY OPERATING PROPERTY;  
 LOTS 5 TO 12, INCLUSIVE, BLOCK 9, INCLUDING 40.0 FEET OF COMMERCIAL STREET VACATED, LESS  
 NORTHERN PACIFIC RAILWAY OPERATING PROPERTY;  
 LOTS 1 TO 12, INCLUSIVE, BLOCK 10, INCLUDING 40.0 FEET OF COMMERCIAL STREET VACATED AND 1ST  
 STREET VACATED;  
 LOTS 4 TO 12, INCLUSIVE, BLOCK 17, ALL IN BAY VIEW, ACCORDING TO THE PLAT THEREOF RECORDED IN  
 VOLUME 2 OF PLATS AT PAGE 21, RECORDS OF PIERCE COUNTY AUDITOR;  
 SITUATE IN THE CITY OF RUSTON, COUNTY OF PIERCE, STATE OF WASHINGTON.  
 (PER FIRST AMERICAN TITLE INSURANCE CO. POLICY NO. 4262-558565 DATED MAY 02, 2005)  
 PARCEL A:  
 LOT 1 OF M.S. DREWS' PLAT, ACCORDING TO PLAT RECORDED IN BOOK 1 OF PLATS AT PAGE(S) 16, IN  
 TACOMA, PIERCE COUNTY, WASHINGTON.  
 EXCEPT THAT PORTION CONVEYED TO NORTHERN PACIFIC RAILWAY COMPANY BY DEED RECORDED  
 OCTOBER 1, 1912 UNDER AUDITOR'S NO. 368323.  
 ALSO EXCEPT THAT PORTION CONVEYED TO AMERICAN SMELTING AND REFINING COMPANY, A NEW JERSEY  
 CORPORATION, BY DEED RECORDED JANUARY 23, 1923 UNDER AUDITOR'S NO. 655370.  
 PARCEL B:  
 LOT 2, TOGETHER WITH THAT TRIANGULAR PORTION IN THE SOUTHWEST CORNER OF LOT 3, LYING  
 SOUTHWESTERLY OF NORTHERN PACIFIC RAILROAD RIGHT OF WAY OF M.S. DREWS' PLAT, ACCORDING TO  
 PLAT RECORDED IN BOOK 1 OF PLATS AT PAGE(S) 16, IN TACOMA, PIERCE COUNTY, WASHINGTON.  
 PARCEL C:  
 LOT 4 AND ALL OF LOT 5 OF M.S. DREWS' PLAT, ACCORDING TO PLAT RECORDED IN BOOK 1 OF PLATS  
 AT PAGE(S) 16, IN TACOMA, PIERCE COUNTY, WASHINGTON.  
 EXCEPT THAT PORTION CONVEYED TO NORTHERN PACIFIC RAILWAY COMPANY.  
 PARCEL D:  
 THE NORTH 90 FEET OF LOT 6 OF M.S. DREWS' PLAT, ACCORDING TO PLAT RECORDED IN BOOK 1 OF  
 PLATS AT PAGE(S) 16, IN TACOMA, PIERCE COUNTY, WASHINGTON.  
 PARCEL E:  
 LOT 7 OF M.S. DREWS' PLAT, ACCORDING TO PLAT RECORDED IN BOOK 1 OF PLATS AT PAGE(S) 16, IN  
 TACOMA, PIERCE COUNTY, WASHINGTON.  
 PARCEL F:  
 LOT 8 OF M.S. DREWS' PLAT, ACCORDING TO PLAT RECORDED IN BOOK 1 OF PLATS AT PAGE(S) 16, IN  
 TACOMA, PIERCE COUNTY, WASHINGTON.  
 EXCEPT THAT PORTION CONVEYED TO NORTHERN PACIFIC RAILWAY COMPANY.  
 PARCEL G:  
 THOSE PORTIONS OF TRACT E OF M.S. DREWS' PLAT, ACCORDING TO PLAT RECORDED IN BOOK 1 OF  
 PLATS AT PAGE(S) 16, LYING NORTHEASTERLY OF THE RIGHT OF WAY OF THE NORTHERN PACIFIC  
 RAILWAY COMPANY AND SOUTHWESTERLY OF THE TRACT OF LAND CONVEYED TO PORT TOWNSEND  
 SOUTHERN RAILROAD COMPANY BY DEED RECORDED UNDER AUDITOR'S NO. 218183, IN TACOMA, PIERCE  
 COUNTY, WASHINGTON.  
 PARCEL H:  
 THOSE PORTIONS OF TRACTS F, G AND LOT 9 OF M.S. DREWS' PLAT, ACCORDING TO PLAT RECORDED IN  
 BOOK 1 OF PLATS AT PAGE(S) 16, LYING SOUTHWESTERLY OF THOSE TRACTS OF LAND CONVEYED TO  
 PORT TOWNSEND SOUTHERN RAILROAD COMPANY BY DEEDS RECORDED UNDER AUDITOR'S NOS. 2242302,  
 228801, AND 228802, IN TACOMA, PIERCE COUNTY, WASHINGTON.  
 PARCEL I:  
 TRACT 16 OF M.S. DREWS' PLAT, ACCORDING TO PLAT RECORDED IN BOOK 1 OF PLATS AT PAGE(S) 16,  
 IN TACOMA, PIERCE COUNTY, WASHINGTON.  
 EXCEPT THE SOUTH 65 FEET OF THE WEST 100 FEET THEREOF;  
 ALSO EXCEPT WATERVIEW STREET.  
 PARCEL J:  
 TRACT 10 OF M.S. DREWS' PLAT, ACCORDING TO PLAT RECORDED IN BOOK 1 OF PLATS AT PAGE(S) 16,  
 IN TACOMA, PIERCE COUNTY, WASHINGTON.  
 EXCEPT THE WEST 50 FEET OF THE SOUTH HALF THEREOF;  
 ALSO EXCEPT WATERVIEW STREET.  
 PARCEL K:  
 LOT 17 OF M.S. DREWS' PLAT, ACCORDING TO PLAT RECORDED IN BOOK 1 OF PLATS AT PAGE(S) 16, IN  
 TACOMA, PIERCE COUNTY, WASHINGTON.  
 EXCEPT THAT PORTION THEREOF LYING NORTHEASTERLY OF THE SOUTHWESTERLY LINE OF THAT TRACT  
 CONVEYED TO THE PORT TOWNSEND SOUTHERN RAILROAD COMPANY BY DEED DATED SEPTEMBER 25,  
 1906 AND RECORDED OCTOBER 13, 1906 IN BOOK 294 OF DEEDS AT PAGE 433, WHICH TRACT WAS  
 DESCRIBED AS LYING NORTHEASTERLY OF A LINE DRAWN PARALLEL WITH AND 60 FEET DISTANT  
 SOUTHWESTERLY MEASURED AT RIGHT ANGLE FROM THE LOCATED LINE OF PORT TOWNSEND SOUTHERN  
 RAILROAD AS LOCATED AND STAKED OUT ACROSS SAID PREMISES, BEING ALL THAT PART OF SAID LOT  
 LYING NORTHEASTERLY OF A STRAIGHT LINE DRAWN FROM A POINT ON THE SOUTH LINE OF SAID LOT 17,  
 30.77 FEET, MORE OR LESS, WEST FROM THE SOUTHEAST CORNER OF SAID LOT, NORTHWESTERLY TO A  
 POINT ON THE DIVIDING LINE BETWEEN THE NORTH HALF AND THE SOUTH HALF OF LOT 9 IN SAID M.S.  
 DREWS' PLAT, 177.09 FEET, MORE OR LESS, EASTERLY FROM THE NORTHWEST CORNER OF THE SOUTH  
 HALF OF SAID  
 LOT 9;  
 ALSO EXCEPT THAT PART TAKEN AND CONDEMNED BY THE CITY OF TACOMA FOR ROADWAY IN  
 CONDEMNATION PROCEEDINGS UNDER PIERCE COUNTY SUPERIOR COURT CAUSE NO. 27153.  
 PARCEL L:  
 LOT 11 OF M.S. DREWS' PLAT, ACCORDING TO PLAT RECORDED IN BOOK 1 OF PLATS AT PAGE(S) 16, IN  
 TACOMA, PIERCE COUNTY, WASHINGTON.  
 EXCEPT THE SOUTH 70 FEET OF THE EAST HALF THEREOF.

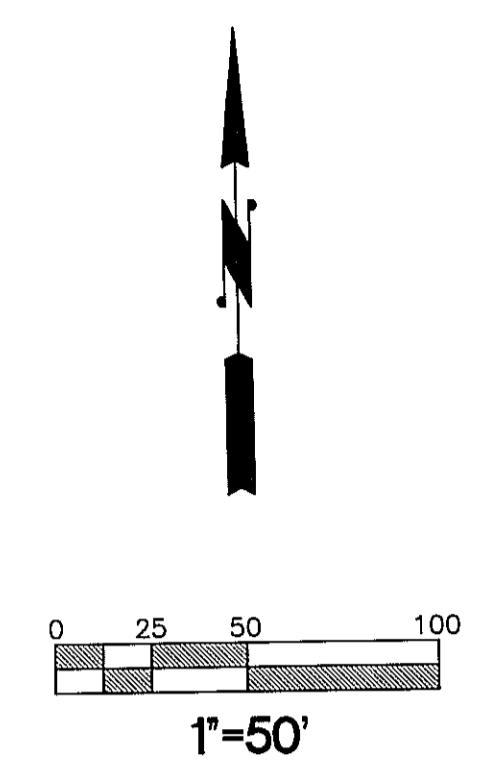

**BASIS OF BEARINGS**  
 WA STATE PLANE COORDINATE SYSTEM,  
 NAD83-91, SOUTH ZONE, AS DEFINED BY THE  
 CITY OF TACOMA DEPT. OF PUBLIC WORKS  
 PUBLISHED COORDINATES FOR MONUMENTS  
 ALONG ORCHARD ST. AT NORTH 49TH STREET  
 (EAST) AND AT NORTH 47TH STREET (EAST)  
 BEARING-S01°32'21\"/>

**VERTICAL DATUM**  
 NGVD29, AS DEFINED BY THE CITY OF  
 TACOMA DEPT. OF PUBLIC WORKS PUBLISHED  
 ELEVATION FOR BENCHMARK #4220, BRASS  
 DISK AT BACK OF CURBLINE OF NORTH 46TH  
 ST. & N. VILLARD ST. INTERSECTION  
 ELEVATION=243.85 FEET

**LEGEND**

- FOUND MONUMENT AS DESCRIBED
- FOUND AS DESCRIBED
- ⊠ CATCH BASIN
- ⊙ STORMDRAIN MANHOLE
- ⊙ BOLLARD
- ⊙ MANHOLE
- ⊙ MONITORING WELL
- DECIDUOUS TREE
- ⊠ SIGN
- ⊙ SANITARY SEWER MANHOLE
- UTILITY POLE
- UTILITY POLE GUY ANCHOR
- ⊙ FIRE HYDRANT
- FIBEROPTIC WITNESS POST
- GATE
- EDGE OF ASPHALT
- FENCE
- TOE OF SLOPE
- TOP OF SLOPE
- OVERHEAD LINE
- AS-BUILT CENTERLINE RAILROAD TRACKS
- COT GIS STORM LINE (APPROX.)
- COT GIS SANITARY SEWER LINE (APPROX.)
- (M) MEASURED
- (C) CALCULATED
- (PR) PROPORTIONED
- (COT) CITY OF TACOMA RECORD
- (D) DEED
- (Rg) PER REFERENCED SURVEY

**SURVEYOR'S REFERENCES**

- (R1) RECORD OF SURVEY BY ROBERT BOYD DATED 1-08-90, AF#9002080114
- (R2) RECORD OF SURVEY BY DANIEL ACKERMAN DATED 8-25-05, AF#200508265010
- (R3) RECORD OF SURVEY BY BLAIR PRIGGE DATED 06-05-01, AF#200108225003
- (R4) RECORD OF SURVEY BY RANDALL HAYDON DATED 02-97, AF#902030060
- (R5) RECORD OF SURVEY BY CHARLES HAVILAND DATED 06-29-90, AF#9001160118
- (R6) RECORD OF SURVEY BY DAVE BERG DATED 07-02-79, AF#2777
- (P1) M.S. DREWS PLAT, VOL. 1 OF PLATS, PG. 16.
- (P2) BAYVIEW ADDITION DATED JUNE 19, 1888.

Call  
 before you  
 Dig  
 1-800-424-5555  
 UNDERGROUND SERVICE (USA)

**NOTE:**  
 EXISTING UTILITY LOCATIONS SHOWN HEREON ARE APPROXIMATE ONLY.  
 IT SHALL BE THE CONTRACTOR'S RESPONSIBILITY TO DETERMINE THE  
 EXACT VERTICAL AND HORIZONTAL LOCATION OF ALL EXISTING UNDER-  
 GROUND UTILITIES PRIOR TO COMMENCING CONSTRUCTION. NO  
 REPRESENTATION IS MADE THAT ALL EXISTING UTILITIES ARE SHOWN  
 HEREON. THE ENGINEER ASSUMES NO RESPONSIBILITY FOR UTILITIES  
 NOT SHOWN OR UTILITIES NOT SHOWN IN THEIR PROPER LOCATION.  
 CALL BEFORE YOU DIG: 1-800-424-5555

REFER TO SHEET 1 FOR  
 NARRATIVE AND NOTES

MATCHLINE - SEE SHEET 3 OF 3

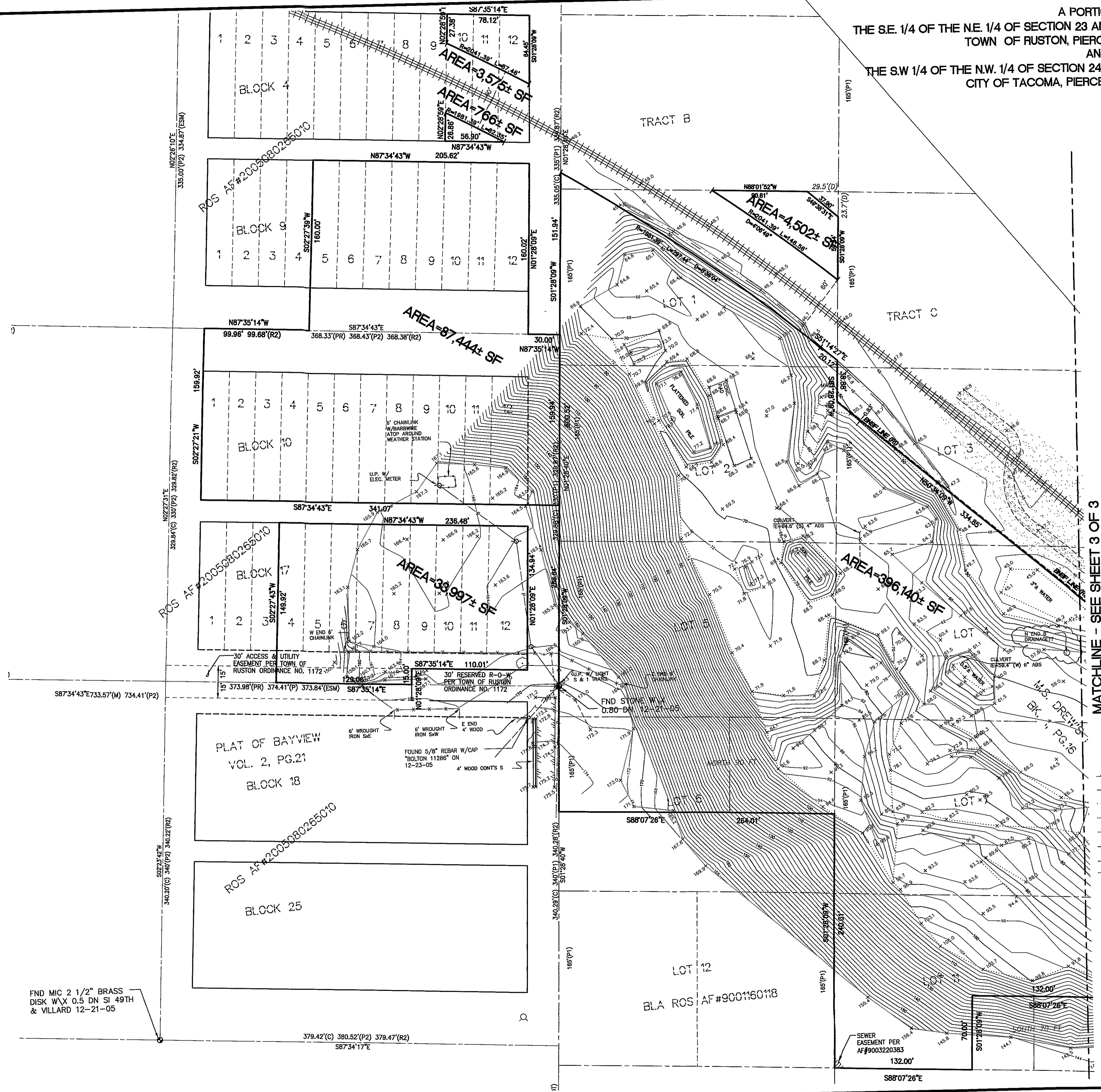

DESIGNED	N/A			
DRAWN	WEL			
CHECKED	TUN/GCA			
DATE	APR, 2006			
SCALE	1"=50'			
No.	Date	By	Appr.	Revision

**BASELINE ENGINEERING, INC.**  
 Land Development Professional Services  
 (253)565-4491 • Seattle (206)824-1205 • FAX (253)565-8563  
 Land Planning & Use • Engineering • Surveying  
 1910-64th Avenue West, • Tacoma, WA 98466

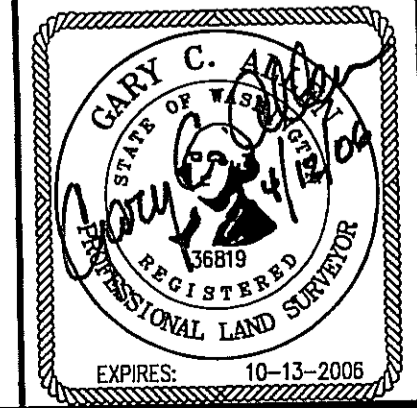

OWNER/DEVELOPER:  
 DAVE BAUMGARDNER  
 4016 52ND AVE. CT. N.W.  
 GIG HARBOR, WA 98335

TITLE:  
 BOUNDARY AND TOPOGRAPHIC SURVEY  
 WEST HALF OF SITE  
**BAUMGARDNER**  
 RUSTON AND TACOMA WASHINGTON

SHEET	2 OF 3
JOB NO.	03037.1

A PORTION OF  
 THE S.E. 1/4 OF THE N.E. 1/4 OF SECTION 23 AND TOWNSHIP 21 NORTH, RANGE 2 EAST, W.M.  
 TOWN OF RUSTON, PIERCE COUNTY, WASHINGTON  
 AND  
 THE S.W. 1/4 OF THE N.W. 1/4 OF SECTION 24, TOWNSHIP 21 NORTH, RANGE 2 EAST, W.M.  
 CITY OF TACOMA, PIERCE COUNTY, WASHINGTON

**LEGAL DESCRIPTION**

(PER COMMONWEALTH LAND TITLE CO. ORDER NO. RM-20184052, DATED SEP. 28, 2005)  
 LOTS 10 TO 12, INCLUSIVE, BLOCK 4, LESS NORTHERN PACIFIC RAILWAY OPERATING PROPERTY;  
 LOTS 5 TO 12, INCLUSIVE, BLOCK 9, INCLUDING 40.0 FEET OF COMMERCIAL STREET VACATED, LESS  
 NORTHERN PACIFIC OPERATION PROPERTY;  
 LOTS 1 TO 12, INCLUSIVE, BLOCK 10, INCLUDING 40.0 FEET OF COMMERCIAL STREET VACATED AND 1ST  
 STREET VACATED;  
 LOTS 4 TO 12, INCLUSIVE, BLOCK 17, ALL IN BAY VIEW, ACCORDING TO THE PLAT THEREOF RECORDED IN  
 VOLUME 2 OF PLATS AT PAGE 21, RECORDS OF PIERCE COUNTY AUDITOR;  
 SITUATE IN THE CITY OF RUSTON, COUNTY OF PIERCE, STATE OF WASHINGTON.  
 (PER FIRST AMERICAN TITLE INSURANCE CO. POLICY NO. 4282-568665 DATED MAY 02, 2005)  
 PARCEL A:  
 LOT 1 OF M.S. DREWS' PLAT, ACCORDING TO PLAT RECORDED IN BOOK 1 OF PLATS AT PAGE(S) 16, IN  
 TACOMA, PIERCE COUNTY, WASHINGTON.  
 EXCEPT THAT PORTION CONVEYED TO NORTHERN PACIFIC RAILWAY COMPANY BY DEED RECORDED  
 OCTOBER 1, 1912 UNDER AUDITOR'S NO. 368323;  
 ALSO EXCEPT THAT PORTION CONVEYED TO AMERICAN SMELTING AND REFINING COMPANY, A NEW JERSEY  
 CORPORATION, BY DEED RECORDED JANUARY 23, 1923 UNDER AUDITOR'S NO. 655370.  
 PARCEL B:  
 LOT 2, TOGETHER WITH THAT TRIANGULAR PORTION IN THE SOUTHWEST CORNER OF LOT 3, LYING  
 SOUTHWESTERLY OF NORTHERN PACIFIC RAILROAD RIGHT OF WAY OF M.S. DREWS' PLAT, ACCORDING TO  
 PLAT RECORDED IN BOOK 1 OF PLATS AT PAGE(S) 16, IN TACOMA, PIERCE COUNTY, WASHINGTON.

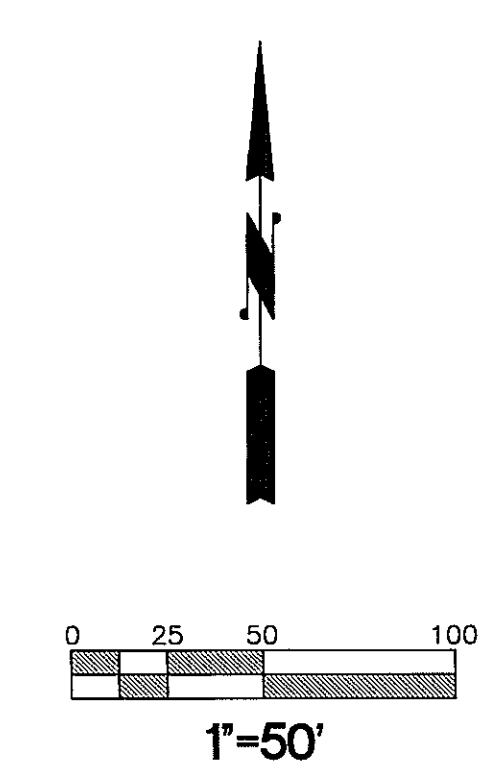

**BASIS OF BEARINGS**  
 WA. STATE PLANE COORDINATE SYSTEM,  
 NAD83-91, SOUTH ZONE, AS DEFINED BY THE  
 CITY OF TACOMA DEPT. OF PUBLIC WORKS  
 PUBLISHED COORDINATES FOR MONUMENTS  
 ALONG ORCHARD ST. AT NORTH 49TH STREET  
 (EAST) AND AT NORTH 47TH STREET (EAST)  
 BEARING=S01°32'21"W

**VERTICAL DATUM**  
 NGVD29, AS DEFINED BY THE CITY OF  
 TACOMA DEPT. OF PUBLIC WORKS PUBLISHED  
 ELEVATION FOR BENCHMARK #4220, BRASS  
 DISK AT BACK OF CURBLINE OF NORTH 46TH  
 ST. & N. WILLARD ST. INTERSECTION  
 ELEVATION=243.85 FEET

**LEGEND**

- ⊙ FOUND MONUMENT AS DESCRIBED
- FOUND AS DESCRIBED
- ⊠ CATCH BASIN
- ⊕ STORMDRAIN MANHOLE
- BOLLARD
- ⊙ MANHOLE
- ⊕ MONITORING WELL
- DECIDUOUS TREE
- ⊠ SIGN
- ⊕ SANITARY SEWER MANHOLE
- UTILITY POLE
- UTILITY POLE GUY ANCHOR
- ⊕ FIRE HYDRANT
- ⊕ FIBEROPTIC WITNESS POST
- ⊕ GATE
- EDGE OF ASPHALT
- FENCE
- TOE OF SLOPE
- TOP OF SLOPE
- OVERHEAD LINE
- AS-BUILT CENTERLINE RAILROAD TRACKS
- COT GIS STORM LINE (APPROX.)
- COT GIS SANITARY SEWER LINE (APPROX.)
- (M) MEASURED
- (C) CALCULATED
- (PR) PROPORTIONED
- (COT) CITY OF TACOMA RECORD
- (D) DEED
- (R#) PER REFERENCED SURVEY

PARCEL C:  
 LOT 4 AND ALL OF LOT 5 OF M.S. DREWS' PLAT, ACCORDING TO PLAT RECORDED IN BOOK 1 OF PLATS  
 AT PAGE(S) 16, IN TACOMA, PIERCE COUNTY, WASHINGTON.  
 EXCEPT THAT PORTION CONVEYED TO NORTHERN PACIFIC RAILWAY COMPANY.

PARCEL D:  
 THE NORTH 90 FEET OF LOT 6 OF M.S. DREWS' PLAT, ACCORDING TO PLAT RECORDED IN BOOK 1 OF  
 PLATS AT PAGE(S) 16, IN TACOMA, PIERCE COUNTY, WASHINGTON.

PARCEL E:  
 LOT 7 OF M.S. DREWS' PLAT, ACCORDING TO PLAT RECORDED IN BOOK 1 OF PLATS AT PAGE(S) 16, IN  
 TACOMA, PIERCE COUNTY, WASHINGTON.

PARCEL F:  
 LOT 8 OF M.S. DREWS' PLAT, ACCORDING TO PLAT RECORDED IN BOOK 1 OF PLATS AT PAGE(S) 16, IN  
 TACOMA, PIERCE COUNTY, WASHINGTON.  
 EXCEPT THAT PORTION CONVEYED TO NORTHERN PACIFIC RAILWAY COMPANY.

PARCEL G:  
 THOSE PORTIONS OF TRACT E OF M.S. DREWS' PLAT, ACCORDING TO PLAT RECORDED IN BOOK 1 OF  
 PLATS AT PAGE(S) 16, LYING NORTHEASTERLY OF THE RIGHT OF WAY OF THE NORTHERN PACIFIC  
 RAILWAY COMPANY AND SOUTHWESTERLY OF THE TRACT OF LAND CONVEYED TO PORT TOWNSEND  
 SOUTHERN RAILROAD COMPANY BY DEED RECORDED UNDER AUDITOR'S NO. 218183, IN TACOMA, PIERCE  
 COUNTY, WASHINGTON.

PARCEL H:  
 THOSE PORTIONS OF TRACTS F, G AND LOT 9 OF M.S. DREWS' PLAT, ACCORDING TO PLAT RECORDED IN  
 BOOK 1 OF PLATS AT PAGE(S) 16, LYING SOUTHWESTERLY OF THOSE TRACTS OF LAND CONVEYED TO  
 PORT TOWNSEND SOUTHERN RAILROAD COMPANY BY DEEDS RECORDED UNDER AUDITOR'S NOS. 2242302,  
 228801, AND 228802, IN TACOMA, PIERCE COUNTY, WASHINGTON.

PARCEL I:  
 TRACT 16 OF M.S. DREWS' PLAT, ACCORDING TO PLAT RECORDED IN BOOK 1 OF PLATS AT PAGE(S) 16,  
 IN TACOMA, PIERCE COUNTY, WASHINGTON.  
 EXCEPT THE SOUTH 65 FEET OF THE WEST 100 FEET THEREOF;  
 ALSO EXCEPT WATERVIEW STREET.

PARCEL J:  
 TRACT 10 OF M.S. DREWS' PLAT, ACCORDING TO PLAT RECORDED IN BOOK 1 OF PLATS AT PAGE(S) 16,  
 IN TACOMA, PIERCE COUNTY, WASHINGTON.  
 EXCEPT THE WEST 50 FEET OF THE SOUTH HALF THEREOF;  
 ALSO EXCEPT WATERVIEW STREET.

PARCEL K:  
 LOT 17 OF M.S. DREWS' PLAT, ACCORDING TO PLAT RECORDED IN BOOK 1 OF PLATS AT PAGE(S) 16, IN  
 TACOMA, PIERCE COUNTY, WASHINGTON.  
 EXCEPT THAT PORTION THEREOF LYING NORTHEASTERLY OF THE SOUTHWESTERLY LINE OF THAT TRACT  
 CONVEYED TO THE PORT TOWNSEND SOUTHERN RAILROAD COMPANY BY DEED DATED SEPTEMBER 25,  
 1908 AND RECORDED OCTOBER 13, 1908 IN BOOK 294 OF DEEDS AT PAGE 433, WHICH TRACT WAS  
 DESCRIBED AS LYING NORTHEASTERLY OF A LINE DRAWN PARALLEL WITH AND 60 FEET DISTANT  
 SOUTHWESTERLY MEASURED AT RIGHT ANGLE FROM THE LOCATED LINE OF PORT TOWNSEND SOUTHERN  
 RAILROAD AS LOCATED AND STAKED OUT ACROSS SAID PREMISES, BEING ALL THAT PART OF SAID LOT  
 LYING NORTHEASTERLY OF A STRAIGHT LINE DRAWN FROM A POINT ON THE SOUTH LINE OF SAID LOT 17,  
 30.77 FEET, MORE OR LESS, WEST FROM THE SOUTHWEST CORNER OF SAID LOT, NORTHWESTERLY TO A  
 POINT ON THE DIVIDING LINE BETWEEN THE NORTH HALF AND THE SOUTH HALF OF LOT 9 IN SAID M.S.  
 DREWS' PLAT, 177.09 FEET, MORE OR LESS, EASTERLY FROM THE NORTHWEST CORNER OF THE SOUTH  
 HALF OF SAID  
 LOT 9;  
 ALSO EXCEPT THAT PART TAKEN AND CONDEMNED BY THE CITY OF TACOMA FOR ROADWAY IN  
 CONDEMNATION PROCEEDINGS UNDER PIERCE COUNTY SUPERIOR COURT CAUSE NO. 27163.

PARCEL L:  
 LOT 11 OF M.S. DREWS' PLAT, ACCORDING TO PLAT RECORDED IN BOOK 1 OF PLATS AT PAGE(S) 16, IN  
 TACOMA, PIERCE COUNTY, WASHINGTON.  
 EXCEPT THE SOUTH 70 FEET OF THE EAST HALF THEREOF.

REFER TO SHEET 1 FOR  
 NARRATIVE AND NOTES

Call  
 before you  
 Dig  
 1-800-424-5555  
 UNDERGROUND SERVICE (USA)

**NOTE:**  
 EXISTING UTILITY LOCATIONS SHOWN HEREON ARE APPROXIMATE ONLY.  
 IT SHALL BE THE CONTRACTOR'S RESPONSIBILITY TO DETERMINE THE  
 EXACT VERTICAL AND HORIZONTAL LOCATION OF ALL EXISTING UNDER-  
 GROUND UTILITIES PRIOR TO COMMENCING CONSTRUCTION. NO  
 REPRESENTATION IS MADE THAT ALL EXISTING UTILITIES ARE SHOWN  
 HEREON. THE ENGINEER ASSUMES NO RESPONSIBILITY FOR UTILITIES  
 NOT SHOWN OR UTILITIES NOT SHOWN IN THEIR PROPER LOCATION.  
 CALL BEFORE YOU DIG. 1-800-424-5555

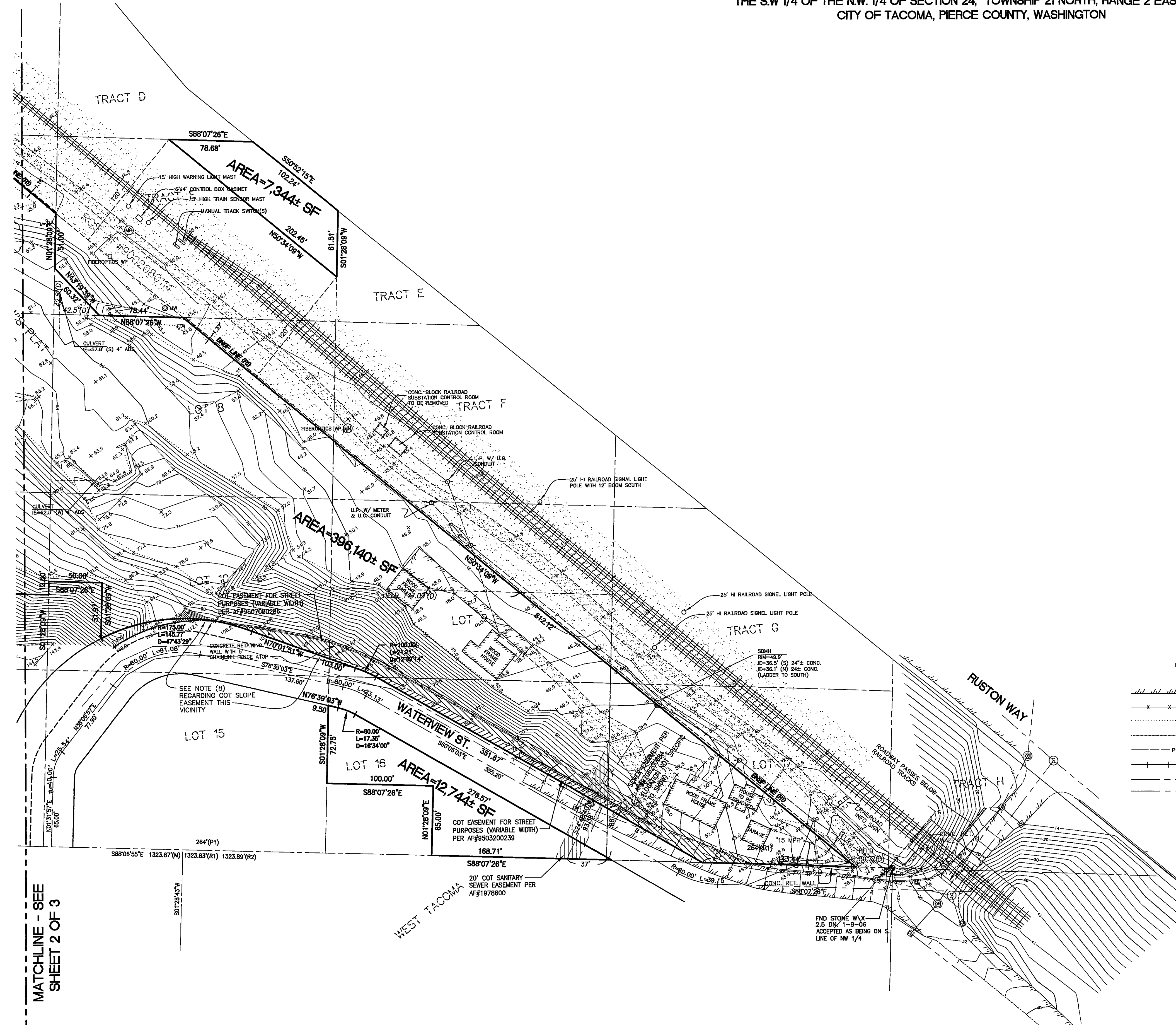

MATCHLINE - SEE  
 SHEET 2 OF 3

DESIGNED	N/A			
DRAWN	WEL			
CHECKED	TJN/GCA			
DATE	APR., 2006			
SCALE	1"=50'			
No.	Date	By	Appr.	Revision

**BASELINE ENGINEERING, INC.**  
*Land Development Professional Services*  
 (253)565-4491 • Seattle (206)824-1205 • FAX (253)565-8563  
 Land Planning & Use • Engineering • Surveying  
 1910-64th Avenue West, • Tacoma, WA 98466

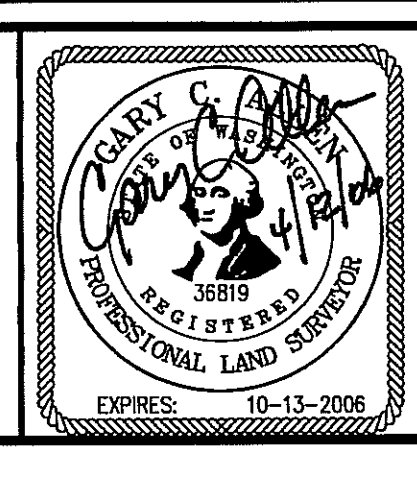

OWNER/DEVELOPER:  
**DAVE BAUMGARDNER**  
 4016 52ND AVE. CT. N.W.  
 GIG HARBOR, WA 98335

TITLE:  
**BOUNDARY AND TOPOGRAPHIC SURVEY**  
**EAST HALF OF SITE**  
**BAUMGARDNER**  
 RUSTON AND TACOMA WASHINGTON

SHEET	3 OF 3
JOB NO.	03037.1

FW: Home in Tacoma inquiry and request for UFG-3 SITE PLAN

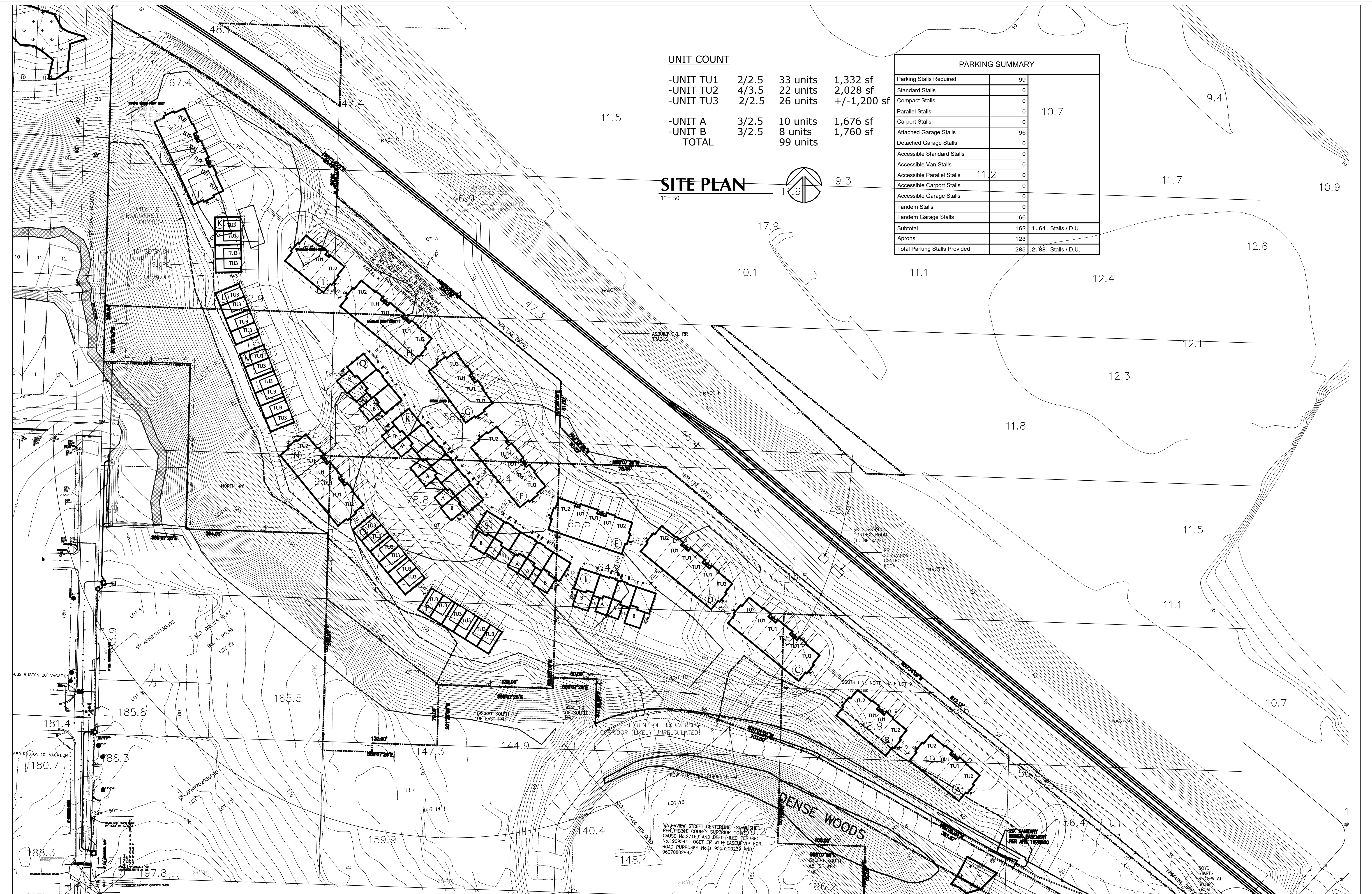

**UNIT COUNT**

-UNIT TU1	2/2.5	33 units	1,332 sf
-UNIT TU2	4/3.5	22 units	2,028 sf
-UNIT TU3	2/2.5	26 units	+/-1,200 sf
-UNIT A	3/2.5	10 units	1,676 sf
-UNIT B	3/2.5	8 units	1,760 sf
<b>TOTAL</b>		<b>99 units</b>	

**PARKING SUMMARY**

Parking Stalls Required	99	
Standard Stalls	0	10.7
Compact Stalls	0	
Parallel Stalls	0	
Carport Stalls	0	
Attached Garage Stalls	96	
Detached Garage Stalls	0	
Accessible Standard Stalls	0	
Accessible Van Stalls	0	
Accessible Parallel Stalls	11.2	
Accessible Carport Stalls	0	
Accessible Garage Stalls	0	
Tandem Stalls	0	
Tandem Garage Stalls	66	
Subtotal	162	1.64 Stalls / D.U.
Aprons	123	
<b>Total Parking Stalls Provided</b>	<b>285</b>	<b>2.88 Stalls / D.U.</b>

**SITE PLAN**  
1" = 50'

---

**HIT-2 - Hearing: Home in Tacoma - View of Home in Tacoma - some photos.**

1 message

---

**Kit Burns** <kburns.wcb@gmail.com>  
To: Kit Burns <kburns.wcb@gmail.com>

Tue, Sep 24, 2024 at 4:46 PM

On Sep 23, 2024, at 4:17 PM, Kit Burns 1 <kburns.wcb@gmail.com> wrote:



6th and Sheridan





6th and cross street around the bank/ Just off of 6th Avenue near High Voltage Records.



Scale? Appearance?

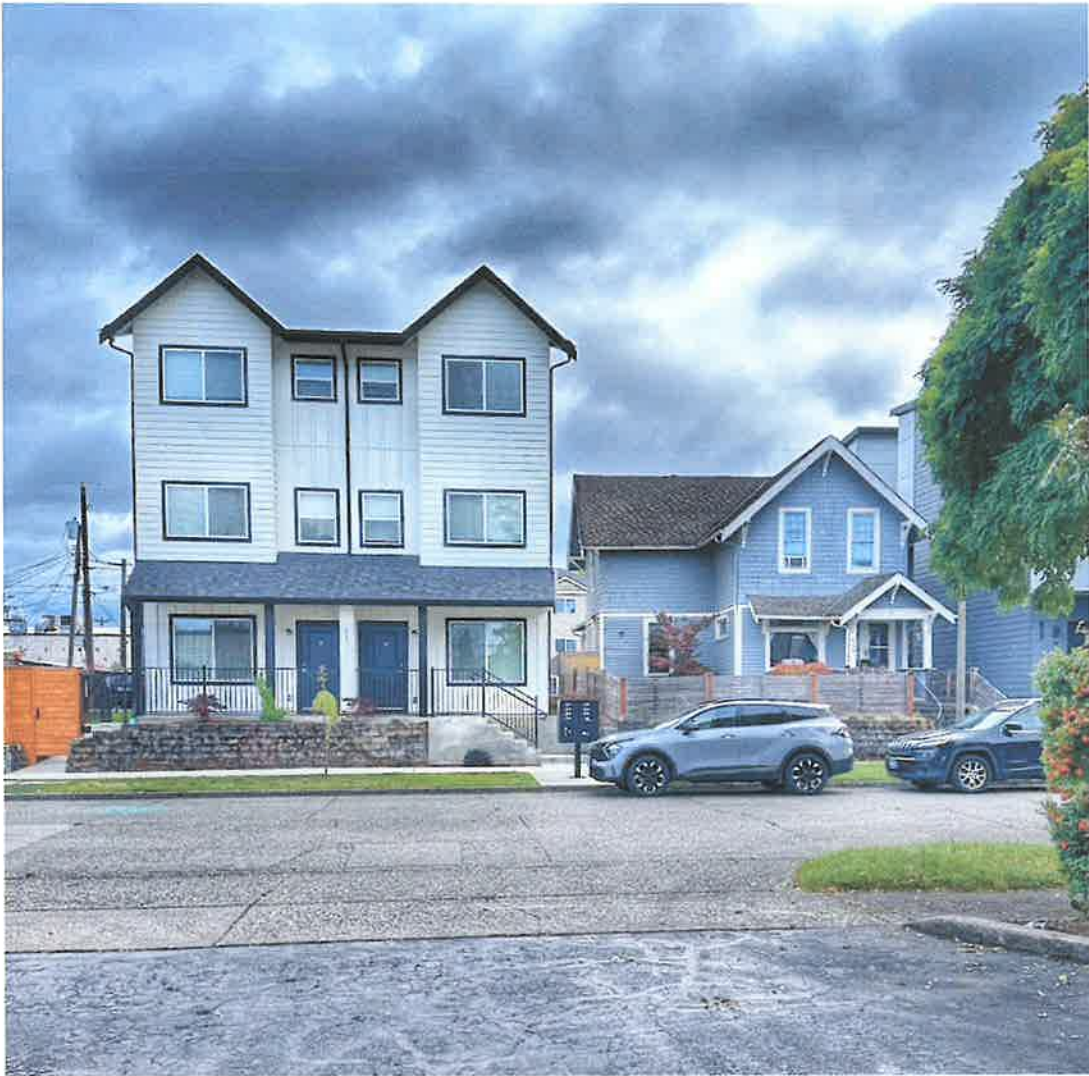

Not fitting in very well?



View from street.

Kit Burns  
PO Box 2341  
Tacoma WA 98401

---

**Fwd: HIT 2: HEARING - September 24th, 2024 - 610 S. 34th near Lincoln High School**

1 message

---

**Kit Burns** <kburns.wcb@gmail.com>  
To: Kit Burns <kburns.wcb@gmail.com>

Tue, Sep 24, 2024 at 4:31 PM

Tax Lot Id: **2084040040**

----- Forwarded message -----

From: **Kit Burns** <kburns.wcb@gmail.com>**Subject: 610 S. 34th near Lincoln High School**

Height limit in this zone is 60 feet. These are 32 feet high.  
8 units on a 6,500 Square Foot Lot.



Housing across the street.

Housing across the street. It is impossible to believe the City when they said in HIT-1 that the housing would be compatible with the neighborhood in the style, shape, character, of current housing.

Similar in scale, design, and compatible with the neighbors.

Where is one we can see?



Comparison. One house previously, now 8 houses (duplex they call them).  
On the same size lot as the formerly single family residence. 6,500 square feet.

The HIT2 aggressively adds housing without parking (only 4 stalls, maybe) for up to 8 units in a UR-1 zone and 12 units in a UR-2 zone and 16 units in a UR-3 zone (all of them with only 4 parking stalls and sometimes less or none at all).

### **Tacoma's HIT2 requirements far exceed the state requirements for increasing density. Why?**

It will destroy neighborhoods with tall boxes which don't fit in the neighborhood and will enrich contractors *but not make housing affordable*.

If someone claims it will make affordable housing (it will not), have them provide the evidence in writing.

The UR-1 max should be 4 units. The UR-2 should be max 6 units. The UR-3 should also be limited.

**See the Tacoma Mall Sub-area plan.** Walk the entire Madison Elementary area noting where sidewalks and trees are missing.

Madison Elementary was sold to a private developer to put 180 units or possibly more units.

Now where can children play? The adjacent cemetery might be a place. Crossing S.47th would be a grave concern for any parent with children.

The future of Tacoma? Missing sidewalks and trees without a place for children to play? One location in this area has "front doors" which open onto an alley without a sidewalk.

Check it out. . .

*Walk the area, all streets, early Saturday morning.  
What do you think? A future of Tacoma based on HIT 2.*



**Not close to being accessible.** This configuration is allowed for 'duplexes' per the Washington State Building Code.

It prevents a person in a wheelchair or with mobility issues from continuing to live in place.

Or from moving into this place by placing an insurmountable barrier at the doorway.

And this was granted a tax exemption using the MFTE but doesn't allow for everyone to live here.

A woman I know who's father is wheel chair bound cannot live here.

Why is housing being built that doesn't meet the basic accessible requirements allowed to be built?

This is the front yard. Not a tree where there could be a very large tree on this lot and other lots along S 34th.

Instead they planted tiny trees on the property which will not address the need for trees nor provide shade to reduce heat island effects in the city.



Not well placed. It does have an irrigation system. Tiny trees. A total of 7 trees on the site if I counted correctly.



These 8 units tower over the neighbors single residence on each side.

This is what HIT 2 will bring throughout Tacoma. Parking for 4 vehicles. This is not near a **"major transit spot."**



The frequency should be every 15 minutes per WSDOT.

How can the City of Tacoma change the definition and have the frequency lowered to **every 30 minutes?**

This must not be allowed. The city would destroy the accepted definition of WSDOT making it meaningless.

Empty promises of "well, in the future we will increase the frequency on these routes" don't pass the smell test and must not be accepted.



Opportunity for real trees. Instead just small trees are planted. No street trees in the ROW. The building could have been lowered. It appears the first floor is higher than the original residence and higher than neighbors' house's. Grading the site could have accommodated a lower profile and flush entry making the lower units accessible for people with mobile disabilities.

It would have required a little bit of thinking.



Near Lincoln High. S 34th and S. Tacoma Ave.

Little boxes that don't reflect the neighborhood for scale, size, or design.

**HIT 2 needs to be rejected.** *Go back to the drawing board.*

Kit Burns  
PO Box 2341  
Tacoma, WA. 98401

"War is meant to be endless". Stop War.

Tom Rickey, 1522 S Fernside Drive, Tacoma

~~Mayor Woodard~~, <sup>MAYOR</sup> Deputy Hines, members, and planners:

## **We need affordable housing for everyone!**

I Support House Bill 1110 and NOT <sup>the</sup> ~~an~~ overreaching Home-in-Tacoma.

Home-in-Tacoma's attempt to provide "affordable housing" is a noble goal  
But the **NOT** the way to go about it.

Allowing hi-density apartment living in single family neighborhoods changes their entire fabric. Increases traffic and creates parking problems on crowded streets, increases property crime because of more cars left on streets. Associated real costs would **NOT** be anywhere near affordable.

City council Please- immediately conduct a tour of once-great Ballard in the City of Seattle to see "unintended consequences" of extreme levels of infill. **Affordability not solved**- it's getting worse! Ballard's high density, inadequate parking, super high housing costs both in purchase and rentals. Rooms alone rent for \$1,000 per month. Homes over \$4,000. Quality of life suffering! What began as Win-Win, became a **WIN** for city planners and a **LOSS** for residents.

Please consider alternatives – Why not simplified housing permits for churches and other charitable groups, such as California does with their State Bill 4, enacted in 2023 allows 30 units per acre - fast-tracked and affordable!

**But**, Home-in-Tacoma wants to <sup>Repurpose</sup> ~~take~~ vacant land next to a single home, or worse tear down existing single family homes - a waste of precious environmental resources. Then speculators will sell Market Rate, **non-affordable**, housing!

<sup>with respect to council</sup>  
It's too important a decision to be made by 8 city council members and our esteemed Mayor Wood-ard.

Goal is good, methodology and millions spent to create and promulgate Home-in-Tacoma **versus simply following what HB 1110 does – is suspect.** Listen to all citizens and then courageously do the right thing and put it to a vote of all of Tacoma's voters!

THANK YOU

Thy ✓

9/24/2024

1522 S. Fernside Dr.  
TACOMA WA 98465

**From:** Rita Andreeva <ritandreeva@gmail.com>  
**Sent:** Thursday, September 19, 2024 7:15 PM  
**To:** Hines, John; Hines, John; City Clerk's Office; City Manager; Scott, Jamika  
**Subject:** TPU is cheating Tacoma residents

Dear members of Tacoma government:

I moved recently. When I received the first couple of utility bills i noticed that the amounts were quite a bit higher than before I moved. So I read the bills carefully. I found what caused the increase – wastewater amount. My wastewater amount on the last 2 bills was 6 times what it had been at my last address increasing my bill by \$60! I called TPU water and was told that I should try calling Environmental Services department, choose Option 3 for Wastewater billing and ask them to adjust the bill to reflect my past wastewater use. When I called them and asked to adjust my rate, the woman who answered the phone said that it couldn't be done, because every time a person moved a city average was applied. She said that when one moves, a city average is used which is calculated November through March. I tried arguing with her, but she wouldn't budge and kept telling me the rule is the rule. She said the rule is in the Tacoma Ordinance. So I asked her to email me a copy of that ordinance, hung up, waited for the email from her, and then read the Ordinance:

#### 12.08B.210 Rates and fees for wastewater service inside the City limits

Paragraph C. For new residential services or account holders which have incomplete or no winter flow records available, the monthly flow portion of the Residential Flow Rate for wastewater service shall be computed using the flows listed below:

Single-family Dwellings - 6.0 ccf per month.

It clearly says black on white: “For account holders which have no winter flow records available” which seemed pretty obvious to mean that this would not apply to me. since I had years of uninterrupted winter records. So I called the Wastewater Billing back.

I got lucky this time – a different person answered the phone and when I explained my problem to her, she immediately told me that she will adjust my wastewater rate based on my prior wastewater use history. I asked her why the other lady whom I talked to first refused to honor my request citing the ordinance, which plainly states that the default rate should only apply to people who have no winter flow records available. She couldn't answer my question, except to say that the TPU has a policy of doing it that way for everyone who moves to a new address within the City of Tacoma. In other words, TPU has a policy of cheating people and hoping that they don't notice!

If i hadn't asked for the ordinance text, if i hadn't noticed that it was misinterpreted by TPU, if i hadn't been lucky when i called the second time, I would have paid a huge extra amount until April of 2025, the time when they hopefully would recalculate my wastewater use!

I calculated how much in excess I would have paid:

From my last bill at my new address: June - August \$72

From my bills from my previous address the average wastewater use was

2.18 ccf = \$12 for 2 months

Excess charges at new address = \$72 - \$12 = \$60 for 2 months x 8.5 months

Therefore, if I had not called the 2<sup>nd</sup> time and got lucky by having a nice person answer the phone, I would have

ended up paying through next April which would have amounted to \$275.

TPU not only does not look at the person's water use history at previous addresses as it should, but it also looks like it uses a 3-person family average and doesn't take in the consideration the number of persons. So if a single person moves into a Tacoma address they are automatically charged as if they were 3 people. Which is also not fair.

If I had not persisted in getting my billing corrected and ended up paying extra \$275, the question comes to mind: how many people in City of Tacoma move every year, and how many of those never read their entire utility bill and question their wastewater amount, and how much money TPU has been pocketing through this dishonest practice?

I ask the City government that you audit TPU wastewater bills for as far back as possible and refund everyone who was overcharged in this manner. I ask that the City government mandates TPU to stop using this deceptive billing tactic immediately.

Sincerely,

M.Andreeva

**From:** Kerby, Kimberly (Legal)  
**Sent:** Monday, September 16, 2024 12:55 PM  
**To:** Haigh, Susan (Legal); Wing, Elizabeth (Legal)  
**Cc:** City Clerk's Office  
**Subject:** Public Comment - Michele Reich  
**Attachments:** 1844\_001.pdf

Please see the attached letter received.

Thank you,  
Kimberly Kerby  
City of Tacoma | City Clerk's Office  
253.591.5153



---

**From:** DoNotReply@cityoftacoma.org <DoNotReply@cityoftacoma.org>  
**Sent:** Monday, September 16, 2024 12:44 PM  
**To:** Kerby, Kimberly (Legal) <KKerby@cityoftacoma.org>  
**Subject:** Attached Image

# Global Cat Day™



On Global Cat Day, October 16, advocates worldwide will join Alley Cat Allies in the movement to protect cats and kittens, Cats Are Community<sup>SM</sup>, and to defend them is to invest in the future well-being of our entire society.

October 16 is also National Feral Cat Day<sup>SM</sup>! This day of action, created by Alley Cat Allies in 2001, is about working on the ground to help community cats (unowned cats who live outdoors), promote Trap-Neuter-Return (TNR), and drive change on cats' behalf.

Join us and be the cats' voice.  
[www.GlobalCatDay.org](http://www.GlobalCatDay.org)

*Pictured Left to Right:  
Ashe—Murfreesboro,  
North Carolina  
Garfield—Versailles, Missouri  
Merlin—Woodstock, Georgia*

**From:** Fred Dowell <freddowell54@gmail.com>  
**Sent:** Friday, September 13, 2024 2:49 PM  
**To:** Hines, John; City Clerk's Office; Rumbaugh, Sarah; Scott, Jamika; Diaz, Olgy; Walker, Kristina; Bushnell, Joe; Daniels, Kiara; Sadalge, Sandesh  
**Subject:** People Park Homeless

There's people up in the hilltop that are upset that the homeless are taking over People's Park again and today it was reported on social media that up individual is taking a tarp and covered the People's Park sign up and the encampment is growing

I wrote earlier this week about this along with some other locations in Tacoma and never got one reply from any of you I've called 311 four times about the encampment on South 48th Street on the east side of the freeway and nothing's being done about it and it's growing every day

When is the city going to pass an ordinance that public camping cannot be allowed in public parks aren't we allowed to do that now since the Supreme Court ruled on it? If so why hasn't the city acted

As I stated before if we don't get any action from the city on this soon I'm I and others are going to contact every TV station in Seattle, Tacoma weekly, newspapers: The News Tribune, and the Volcano papers to see if they'll come down and do a story on this

THIS HAS TO STOP

Fred Dowell



**From:** Fred Dowell <freddowell54@gmail.com>  
**Sent:** Friday, September 13, 2024 2:45 PM  
**To:** Hines, John; Scott, Jamika; Rumbaugh, Sarah; Diaz, Olgy; Walker, Kristina; Daniels, Kiara; Bushnell, Joe; Sadalge, Sandesh; City Clerk's Office  
**Subject:** Concrete being poured at North 30th and Orchard Street

9/12/2024 at 5:50 p.m. a truck from holroyd Corporation was spotted dumping concrete out of their cement truck they had the shoot down after they were pouring concrete at North 30th and North Orchard Street and proceeded to wash the truck off and dumped that's remains of cement down into the city of sewer system at the drain

My friend already called the public works department and they haven't found out who the project engineer is but I want to pass this on to you are we allowing these companies when they're doing the concrete work in the neighborhoods to take the slush at the end of the pour and rits it down our into our sewer systems what's that going to do is that going to block it up how are we going to get that out of the sewer systems

I hope one or all you can find out some information on this and stop this from happening again

Fred Dowell  
Tacoma

**From:** Lindsay Wills <lindsayintacoma@gmail.com>  
**Sent:** Thursday, September 12, 2024 8:11 PM  
**To:** City Clerk's Office  
**Subject:** Written Comment Regarding ShotSpotter

Hello City Council:

I was initially excited to hear that the City would be using ShotSpotter for a trial period. I used to work for a fire department that served the City of East Palo Alto, a jurisdiction that has used ShotSpotter for years. When an activation occurred, my coworkers would be dispatched to the scene so they could provide medical aid if needed. I remember several times when one or more lives were saved because the paramedics were able to arrive quickly, thanks to ShotSpotter.

During my time with Menlo Fire, it never occurred to me that ShotSpotter was a policing tool. I had assumed this was something to help our fire department get to the scene quicker. So I was surprised when I saw that the general response to this pilot program in Tacoma was negative. Now that I've done more research about the technology, I understand why people are concerned. But the reason I'm writing is because I haven't seen any mention of Tacoma Fire being involved in this roll out. I encourage the City to consider having TFD respond to ShotSpotter activations, if this hasn't been discussed already. And if it has - I would love to see info about TFD's involvement on the ShotSpotter FAQ page.

Finally, if ShotSpotter ends up not being the right choice for our city, I hope the Council can make sure that we don't continue with the program.

Thank You,  
Lindsay Wills  
District 4

**From:** jennifer king <smiley31242@gmail.com>  
**Sent:** Friday, September 20, 2024 8:08 AM  
**To:** City Clerk's Office

Hello,

My name is Jennifer. I live at 8425 pacific Ave in Tacoma. We have been having problems with homeless people living on our sidewalk in front of our apartments. They're starting to take up half of the driveway as we pull in. We are at our wits end. We are looking for a solution.

**From:** Korbett Mosesly <korbettm@gmail.com>  
**Sent:** Saturday, September 21, 2024 2:41 AM  
**To:** TCRA; City Clerk's Office  
**Subject:** Urgent Need to Expand Tacoma's Down Payment Assistance Program  
**Attachments:** Tacoma Must Expand Down Payment Assistance and Increase Eligibility for Greater Homeownership Access - Community News Community Article By OLink News.pdf

**Categories:** Community Forum

Dear TCRA Board Members and Committee of the Whole,

The City of Tacoma's Down Payment Assistance Program is an important initiative aimed at addressing homeownership disparities highlighted in the 2021 Homeownership Disparity Study. However, despite offering up to \$60,000 in assistance, there is *currently no housing inventory in Tacoma affordable to families* earning at or below 80% of the area median income (AMI). With rising home prices, this assistance is no longer sufficient, and many families are being priced out of the market.

### **The Current Program Falls Short**

As of September 21, 2024, homes in Tacoma are primarily listed between \$350,000 and \$450,000, with many priced even higher. Below are a few examples:

- [3598 E L St, Tacoma, WA 98404](#) – Listed for \$438,900
- [868 S 34th Street, Tacoma, WA 98418](#) – Listed for \$350,000
- [2522 S Ash Street, Tacoma, WA 98405](#) – Listed for \$420,000
- [2108 Martin Luther King Jr Way, Tacoma, WA 98405](#) – Listed for \$350,000
- [2030 E Division Lane, Tacoma, WA 98404](#) – Listed for \$425,000
- [1119 S 21st Street, Tacoma, WA 98405](#) – Listed for \$384,950

Even with the \$60,000 down payment assistance, families are left with unaffordable mortgage payments. For instance, a \$438,900 home with a \$60,000 down payment leaves the buyer with a \$378,900 mortgage. At current interest rates near 7%, the monthly payments would be around \$2,515, far exceeding what a family earning \$92,650 (the maximum income limit for a family of four under the current program) can reasonably afford.

When factoring in property taxes and insurance, total housing costs push even further beyond what is considered affordable under the 30% of gross income rule, making homeownership unattainable for many.

### **Recommendations for Action**

To address these challenges, I encourage you to review the full list of recommendations here:

[Expand Tacoma's Down Payment Assistance Program](#)

Sincerely,

Korbett Mosesly

### Community Article Search

Posted By **OLink News**



Posted 09/21/2024 in Economic Insights by OLink News



# Tacoma Must Expand Down Payment Assistance and Increase Eligibility for Greater Homeownership Access



The City of Tacoma's Down Payment Assistance Program, operated by the Tacoma Community Redevelopment Authority (TCRA), is an important initiative aimed at addressing the homeownership disparities outlined in the 2021 Homeownership Disparity Study. The program, which offers up to \$60,000 in assistance, is designed to help first-time homebuyers—especially Black households—enter the Tacoma housing market. However, despite the \$60,000 in assistance, there is simply no housing inventory in Tacoma that is affordable for families earning at or below 80% of the area median income (AMI). With housing prices continuing to rise, this level of assistance is no longer enough to make homeownership accessible, leaving many

families priced out of the market. It is time for Tacoma to rethink and expand this program by increasing the down payment assistance amount and adjusting income eligibility limits.

[See Program](#)

## The Current Program Falls Short

Let's consider the homes on the market in Tacoma as of September 21, 2024:

- 3598 E L St, Tacoma, WA 98404 – Listed for \$438,900
- 868 S 34th Street, Tacoma, WA 98418 – Listed for \$350,000
- 2522 S Ash Street, Tacoma, WA 98405 – Listed for \$420,000
- 2108 Martin Luther King Jr Way, Tacoma, WA 98405 – Listed for \$350,000
- 2030 E Division Lane, Tacoma, WA 98404 – Listed for \$425,000
- 1119 S 21st Street, Tacoma, WA 98405 – Listed for \$384,950

These homes are primarily priced between \$350,000 and \$450,000, with many others in Tacoma going for \$500,000 or more. At these price points, the \$60,000 down payment assistance provided by TCRA reduces the mortgage, ***but not by enough to make monthly payments affordable for families*** earning at or below 80% of the area median income (AMI). Even after the assistance, buyers are left with mortgage payments that exceed what many families can reasonably afford.

For example, a \$438,900 home with a \$60,000 down payment still leaves the buyer with a \$378,900 mortgage. With current interest rates near 7%, monthly payments on this mortgage would be approximately \$2,515—far beyond the affordable range for a family earning \$92,650 (the maximum income limit for a family of four under the current program). Given these figures, the mortgage payments alone already exceed what would be considered affordable—based on the 30% of gross income rule. When you factor in property taxes and insurance, the total monthly housing

costs would push the expense even further beyond the program's target affordability, making it unmanageable for families earning \$92,650.

## Recommendations

### 1: Increase Down Payment Assistance

The City of Tacoma should increase the down payment assistance from \$60,000 to at least \$100,000. This would make homes priced in the \$400,000 to \$450,000 range more affordable, reducing the financial strain on first-time homebuyers. For example, with a \$100,000 down payment on a \$425,000 home, the loan amount would drop to \$325,000, resulting in a more manageable monthly mortgage payment.

This adjustment would better align the program with the current housing market, where most homes under \$700,000 are priced in the \$400,000s, and would allow more families to take advantage of Tacoma's homeownership opportunities.

### 2: Mirror the Covenant Program's Eligibility

Tacoma's Down Payment Assistance Program should also consider mirroring the Covenant Down Payment Assistance Program. The Covenant program offers a more flexible approach by setting income limits up to \$112,300 in Pierce County, making it accessible to more moderate-income families. By raising the income eligibility cap in Tacoma's program, the city would open homeownership opportunities to a broader range of families who are currently priced out of the market but still earn too much to qualify for assistance.

Raising the eligibility threshold to at least 100% AMI (around \$115,000 for a family of four) would reflect Tacoma's rising housing costs and enable more families to qualify for the assistance they need to enter the market.



### **3: Open the Program to Families Building DADUs: A Smarter Approach to Affordability**

One innovative solution Tacoma should consider is expanding the Down Payment Assistance Program to support families building Detached Accessory Dwelling Units (DADUs) for income-qualifying family members. This approach would not only create multi-generational living arrangements but also provide a more affordable housing option compared to traditional homeownership or renting.

The average cost to build a small 2-bedroom DADU in Tacoma is around \$220,000. By leveraging \$60,000 to \$100,000 in down payment assistance through the program, families could significantly reduce the upfront costs of building these units, making them a more feasible housing solution for both the homeowner and their relatives.

For instance, after receiving \$60,000 in assistance, the remaining loan of \$160,000 would result in a monthly mortgage payment of approximately \$1,064. With \$100,000 in assistance, the loan would be reduced to \$120,000, resulting in a more affordable monthly payment of around \$798. These costs are far more manageable than the \$1,700+ that income-eligible relatives would otherwise pay in rent for a 2-bedroom unit in Tacoma.

Not only does this approach make homeownership and shared living more affordable, but it also allows homeowners to build wealth through home equity while accommodating family members or generating rental income to offset their own housing costs. DADUs provide financial flexibility, allowing families to support one another without the significant financial burden of purchasing separate homes.

By expanding the program to allow families to build DADUs for income-qualifying relatives, Tacoma would extend the reach of its housing assistance programs while addressing the broader affordability crisis. This solution offers a win-win scenario: families can maintain closer connections, homeowners benefit from lower costs, and relatives avoid the high expense of renting or purchasing in Tacoma's competitive housing market.

#### **4: Prioritize "By and For" Organizations for Outreach and Support**

To ensure the success of the program in reaching its intended beneficiaries, Tacoma must also prioritize working with Black-led, by and for organizations that are dedicated to serving Black communities. These organizations have deep connections within the community and are best positioned to provide culturally competent outreach, support, and program development. By contracting with and supporting these organizations, the city can ensure that more Black families are aware of and able to take full advantage of the down payment assistance program.

This approach goes beyond race-neutral policies and recognizes the importance of community-driven solutions to address the specific challenges faced by Black families in Tacoma. It would align with the city's broader commitments to equity and anti-racism while ensuring the program reaches those most in need.

#### **Better to Rent? Why Renting Can Be a Smarter Option for Lower-Income Households**

For lower-income families, the financial burden of homeownership in Tacoma's expensive market can be overwhelming. Renting at around \$1,700/month often provides more financial flexibility compared to a typical \$2,500+ mortgage payment. The \$800+ difference can be used to:

- Pay off non-asset-related debt,
- Build an emergency savings fund, or
- Invest in education and skills for future income growth.

Renting also helps families avoid the upfront costs of homeownership (e.g., closing costs, maintenance, taxes), preserving their discretionary income and lowering the risk of financial instability. In Tacoma's current market, where homeownership costs offer little room for paying down debt or building assets, renting can be a safer and smarter financial strategy for families with limited incomes.

## Better Affordability for Tacoma Families

If Tacoma wants to seriously address the homeownership inequities its program aims to solve, the city must act quickly to make its down payment assistance program more impactful. Housing prices continue to rise, and \$60,000 is no longer enough to offset the high costs of homeownership. The city should immediately:

- Increase down payment assistance to \$100,000,
- Raise income eligibility limits to include moderate-income families, and
- Expand the program to support DADU construction for income-qualifying relatives.
- Engage Black-led, by and for organizations to ensure effective outreach and support for Black families.

By making these changes, Tacoma would not only help more families achieve homeownership but also ensure that the city's most marginalized communities, particularly Black households, are given real opportunities to build wealth through property ownership.

## Time for Action

Tacoma's housing market is not waiting. As homes under \$700,000 continue to hover in the \$400,000 to \$500,000 range, the city's Down Payment Assistance Program needs to evolve to meet the needs of today's buyers. By making these critical adjustments, Tacoma can take meaningful steps to close the homeownership gap and ensure that more families have the opportunity to secure stable housing and build generational wealth.

Follow Comments ▾

Post a new comment...

Comment

SEPT 20, 2024

HOW IS IT THAT IN SHENZHEN, CHINA, A  
COMMUNIST MEGA CITY OF 12 MILLION, CAN  
ELECTRIFY THEIR CITY INTO THE 21ST CENTURY,  
WHILE A CITY OF 200K+ - SUCH AS TACOMA  
CAN NOT MOVE PAST THE 19TH. CENTURY TECHNOLOGY?



Shenzhen, China, electrified its fleet of 16,000 buses.

ALSO, A FLEET OF 30,000 TAXIS  
HAVE CONVERTED TO E.V.'S!

PHOTO COURTESY OF BILL GATES  
(CLIMATE CRISES):

Sincerely,  
Mitchell Reich

**From:** Daren Holter <darenholter@gmail.com>  
**Sent:** Monday, September 23, 2024 6:55 PM  
**To:** City Clerk's Office  
**Subject:** Community Forum 9.24.2024  
**Attachments:** City Council Community Forum 9.24.2024.docx

Please provide my presentation to Mayor and Council for Tuesdays Meeting.

Daren

September 24, 2024

To whom it may concern:

As I continue the discussion of the Public Works Tidy up Tacoma Crew I want to be clear the current funding source for this program is the General Fund. As all of you should be aware that using tax dollars to maintain the Rights of Ways is a violation of State Law. Your own policy and code puts the maintenance of the Rights of Ways the responsibility of the adjacent property owners. City of Tacoma is currently providing this service to the property owners at no cost. And again, as I stated at last community forum, Gifting of City Services or Gifting of City Funds is illegal and needs to stop immediately. At the end of my presentation related to this topic I will file a formal complaint with the Attorney General's Office and with the Department of Justice. I will provide countless pictures to you, the Mayor and Council, and to the Citizens of Tacoma as provided to me through Public Disclosure Request showing City Crews mowing, edging, trimming/removing trees, trimming vegetation and applying pesticides all of which was performed by the adjacent property owners before this program started. Why should the Citizens pay tax dollars to do someone else's work? I as a citizen of Tacoma would like to have each business district take responsibility for their own areas of town. As a property owner I maintain the Right of Way in front of my home the same as everyone else on my block. Council Member Hines maintains his Rights of Way in front of his home. Stop giving away this service to these business, private home owners, schools, Metro Parks of Tacoma and developers.

Daren H. Holter

Daren H. Holter  
1823 S Visscher St  
Tacoma WA 98465  
253-677-0800  
[darenholter@gmail.com](mailto:darenholter@gmail.com)

Attachment(s)

✓ On 4/2/2024 3:30:24 PM, Tacoma WA Public Records Center wrote:

**Subject:** [Records Center] Public Records Request :: T016080-020124

**Body:**

04/02/2024

Daren Holter  
1823 S. Visscher St  
Tacoma, WA 98465

RE: PDR # T016080-020124

Dear Daren Holter,

Your question was forwarded to the appropriate departments and received the following responses:

"City is not charging businesses for Business District Tidy-Up. This is a service we are providing through the general fund and maintained ROW in the business district benefits all citizens of Tacoma."